

## How to use this manual

---

# A Few Words About Safety

## SERVICE INFORMATION

The service and repair information contained in this manual is intended for use by qualified, professional technicians. Attempting service or repairs without the proper training, tools, and equipment could cause injury to you and/or others. It could also damage this Honda product or create an unsafe condition.

This manual describes the proper methods and procedures for performing service, maintenance, and repairs. Some procedures require the use special tools. Any person who intends to use a replacement part, service procedure or a tool that is not recommended by Honda, must determine the risks to their personal safety and the safe operation of this product.

If you need to replace a part, use Honda Genuine parts with the correct part number or an equivalent part. We strongly recommend that you do not use replacement parts of inferior quality.

## For Your Customer's Safety

Proper service and maintenance are essential to the customer's safety and the reliability of this product. Any error or oversight while servicing this product can result in faulty operation, damage to the product, or injury to others.

### **⚠ WARNING**

**Improper service or repairs can create an unsafe condition that can cause your customer or others to be seriously hurt or killed.**

**Follow the procedures and precautions in this manual and other service materials carefully.**

## For Your Safety

Because this manual is intended for the professional service technician, we do not provide warnings about many basic shop safety practices (e.g., Hot parts-wear gloves). If you have not received shop safety training or do not feel confident about your knowledge of safe servicing practice, we recommend that you do not attempt to perform the procedures described in this manual.

Some of the most important general service safety precautions are given below. However, we cannot warn you of every conceivable hazard that can arise in performing service and repair procedures. Only you can decide whether or not you should perform a given task.

### **⚠ WARNING**

**Failure to properly follow instructions and precautions can cause you to be seriously hurt or killed.**

**Follow the procedures and precautions in this manual carefully.**

## Important Safety Precautions

Make sure you have a clear understanding of all basic shop safety practices and that you are wearing appropriate clothing and using safety equipment. When performing any service task, be especially careful of the following:

- Read all of the instructions before you begin, and make sure you have the tools, the replacement or repair parts, and the skills required to perform the tasks safely and completely.
- Protect your eyes by using proper safety glasses, goggles, or face shields anytime you hammer, drill, grind, or work around pressurized air, pressurized liquids, springs or other stored-energy components. If there is any doubt, put on eye protection.
- Use other protective wear when necessary, for example gloves or safety shoes. Handling hot or sharp parts can cause severe burns or cuts. Before you grab something that looks like it can hurt you, stop and put on gloves.
- Protect yourself and others whenever you have engine-power equipment up in the air. Anytime you lift this product with a hoist, make sure that the hoist hook is securely attached to the product.

Make sure the engine is off before you begin any servicing procedures, unless the instruction tells you to do otherwise. This will help eliminate several potential hazards:

- Carbon monoxide poisoning from engine exhaust. Be sure there is adequate ventilation whenever you run the engine.
- Burns from hot parts. Let the engine and exhaust system cool before working in those areas.
- Injury from moving parts. If the instruction tells you to run the engine, be sure your hands, fingers and clothing are out of the way.

Gasoline vapors and hydrogen gasses from battery are explosive. To reduce the possibility of a fire or explosion, be careful when working around gasoline or batteries.

- Use only a nonflammable solvent, not gasoline, to clean parts.
- Never store gasoline in an open container.
- Keep all cigarettes, sparks, and flames away from the battery and all fuel-related parts.

# INTRODUCTION

This manual covers service and repair procedures for the Honda GCV135 • GCV160 • GCV190 • GSV190 General Purpose Engines. It includes supplements R, S, U, W, X, Y, and Z.

All information contained in this manual is based on the latest product information available at the time of printing. We reserve the right to make changes at any time without notice.

No part of this publication may be reproduced, stored in a retrieval system, or transmitted, in any form by any means, electronic, mechanical, photocopying, recording, or otherwise, without prior written permission of the publisher. This includes text, figures, and tables.

As you read this manual, you will find information that is preceded by a **NOTICE** symbol. The purpose of this message is to help prevent damage to the engine, other property, or the environment.

## SAFETY MESSAGES

Your safety and the safety of others are very important. To help you make informed decisions, we have provided safety messages and other safety information throughout this manual. Of course, it is not practical or possible to warn you about all the hazards associated with servicing these engines. You must use your own good judgement.

You will find important safety information in a variety of forms, including:

- **Safety Labels** – on the engine.
- **Safety Messages** – preceded by a safety alert symbol  and one of three signal words: DANGER, WARNING, or CAUTION.

These signal words mean:

### **DANGER**

You **WILL** be **KILLED** or **SERIOUSLY HURT** if you don't follow instructions.

### **WARNING**

You **CAN** be **KILLED** or **SERIOUSLY HURT** if you don't follow instructions.

### **CAUTION**

You **CAN** be **HURT** if you don't follow instructions.

- **Instructions** – how to service these engines correctly and safely.

**American Honda Motor Co., Inc.  
Service Communications Department**

# CONTENTS

<b>OUTLINE OF CHANGES</b>	<b>1</b>
<b>SPECIFICATIONS</b>	<b>1</b>
<b>SERVICE INFORMATION</b>	<b>2</b>
<b>MAINTENANCE</b>	<b>3</b>
<b>MUFFLER</b>	<b>4</b>
<b>RECOIL STARTER</b>	<b>5</b>
<b>FUEL SYSTEM</b>	<b>6</b>
<b>FLYWHEEL/IGNITION COIL/ FLYWHEEL BRAKE</b>	<b>7</b>
<b>CAM PULLEY/CRANKSHAFT/ PISTON/CYLINDER BLOCK</b>	<b>8</b>
<b>ROTO-STOP®</b>	<b>9</b>
<b>OPERATION</b>	<b>10</b>

---

---

# OUTLINE OF CHANGES

## SUPPLEMENT Z (ADD GCV190)

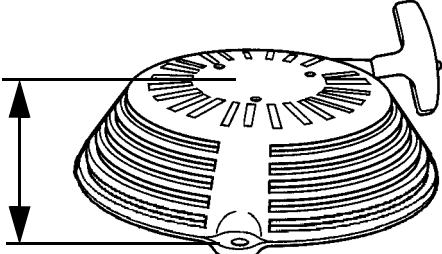
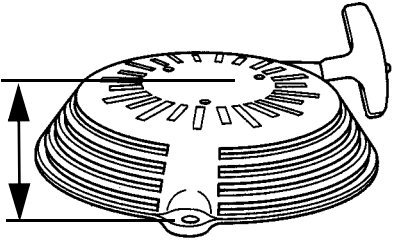
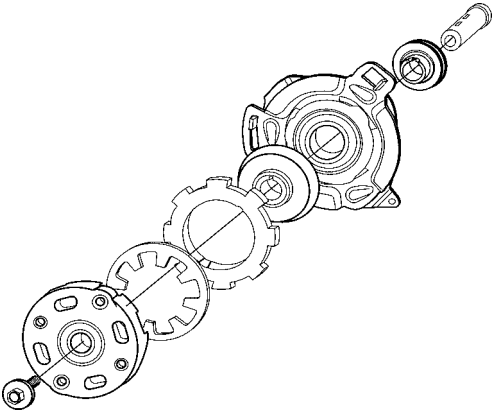
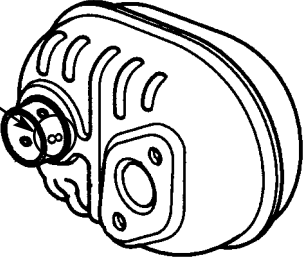
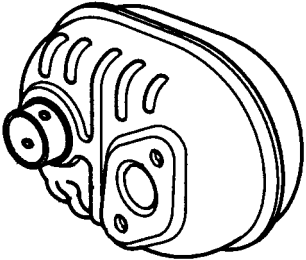
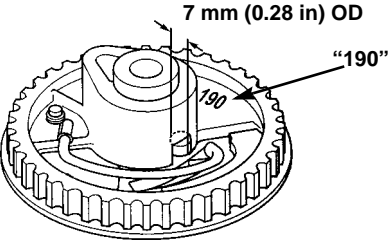
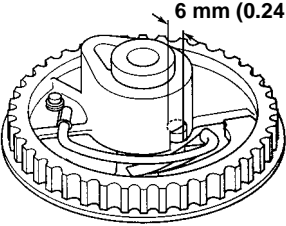
Item	Model	
	GCV190	GCV160
<p><b>RECOIL</b></p> <p>Taller for increased cooling air intake</p>	 <p>8.5 mm (0.33 in) taller</p>	
<p><b>BLADE BRAKE/CLUTCH</b></p> <p>Available on both models</p>		
<p><b>MUFFLER</b></p> <p>Larger volume muffler</p>	<p>Number "8" stamped</p> 	
<p><b>CAM</b></p> <ul style="list-style-type: none"> <li>Larger decompressor pin</li> <li>Identified by "190"</li> </ul>	<p>7 mm (0.28 in) OD</p> <p>"190"</p> 	<p>6 mm (0.24 in) OD</p> 

# OUTLINE OF CHANGES

Item	Model	
	GCV190	GCV160
<p><b>FLYWHEEL</b></p> <ul style="list-style-type: none"> <li>• Tightening torque increased</li> <li>• Larger flywheel nut flange (yellow color)</li> <li>• Plastic screen grid</li> </ul>	<p>32 mm (1.26 in)</p> <p>FLYWHEEL NUT 75 N·m (55 ft-lb)</p> <p>SCREEN GRID (plastic)</p>	<p>FLYWHEEL NUT 52 N·m (38 ft-lb)</p> <p>SCREEN GRID (metal)</p>
<p><b>RINGS</b></p> <ul style="list-style-type: none"> <li>• 3-piece combination type oil control ring</li> </ul>	<p>3-PIECE OIL CONTROL RING</p>	<p>OIL CONTROL RING</p>
<p><b>CRANKSHAFT/PISTON/CONNECTING ROD</b></p> <ul style="list-style-type: none"> <li>• Piston diameter increased</li> <li>• Connecting rod big end ID increased</li> <li>• Crankshaft rod journal OD increased</li> <li>• Piston pin ID decreased</li> </ul>	<p>CONNECTING ROD BIG END ID 30.02 mm (1.182 in)</p> <p>PISTON PIN ID 7.0 mm (0.28 in)</p> <p>PISTON SKIRT OD 68.985 mm (2.7159 in)</p> <p>CRANKSHAFT ROD JOURNAL OD 29.98 mm (1.180 in)</p>	<p>CONNECTING ROD BIG END ID 26.02 mm (1.024 in)</p> <p>PISTON PIN ID 9.0 mm (0.35 in)</p> <p>PISTON SKIRT OD 64.0 mm (2.52 in)</p> <p>CRANKSHAFT ROD JOURNAL OD 25.98 mm (1.123 in)</p>

**FIXED THROTTLE/NON-FLYWHEEL BRAKE TYPES**

Item	Model	
	GCV160 • GCV190 (AFTER MODIFICATION)	GCV160 • GCV190 (BEFORE MODIFICATION)
<p><b>CARBURETOR AND GASKETS</b> (fixed throttle types)</p> <ul style="list-style-type: none"> <li>• Bowl drain bolt eliminated</li> <li>• Air guide plate changed to gasket</li> <li>• Control plate removed and spacer added</li> </ul>		
<p><b>IGNITION COIL</b></p> <ul style="list-style-type: none"> <li>• GX style transistorized ignition coil</li> <li>• Stud bolt (dark gray) dimensions changed to meet coil height change</li> <li>• Flange bolt height increased to meet coil height change</li> </ul>		
<p><b>FLYWHEEL</b></p> <ul style="list-style-type: none"> <li>• Cast-iron flywheel</li> <li>• Separate starter cup, cooling fan, and screen grid (applicable types)</li> </ul>		

# OUTLINE OF CHANGES

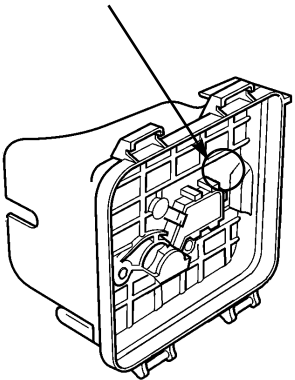
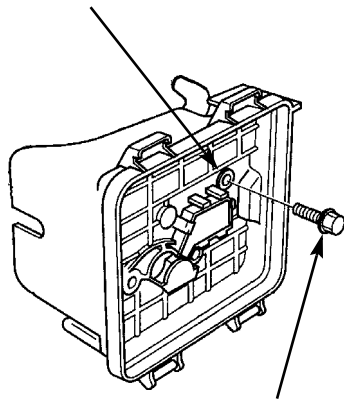
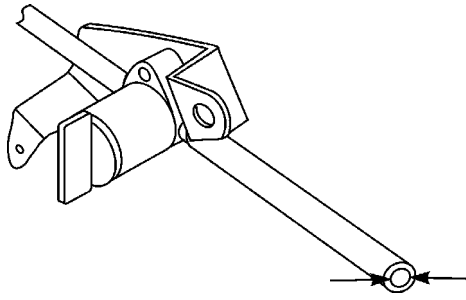
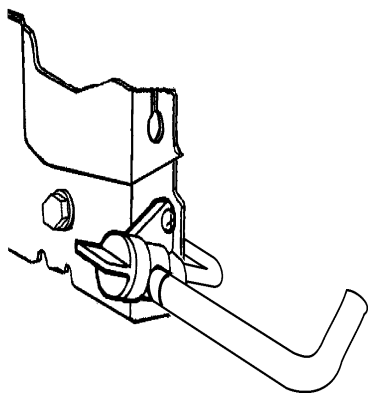
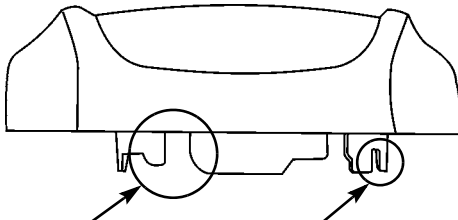
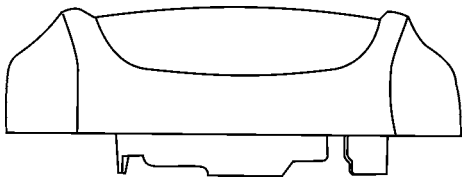
Item	Model	
	GCV190 (AFTER MODIFICATION)	GCV190 (BEFORE MODIFICATION)
<b>AIR CLEANER CASE</b> <ul style="list-style-type: none"> <li>• 6 x 14 mm flange bolt hole eliminated</li> <li>• 6 x 14 mm flange bolt eliminated</li> </ul>	<p>6 x 14 mm BOLT HOLE ELIMINATED</p> 	<p>6 x 14 mm BOLT HOLE</p>  <p>6 x 14 mm FLANGE BOLT</p>
<b>FUEL VALVE</b> (fixed throttle types) <ul style="list-style-type: none"> <li>• Structure changed</li> <li>• Mounting method changed</li> <li>• Fuel tube diameter and shape changed</li> </ul>		
<b>FAN COVER</b> <ul style="list-style-type: none"> <li>• Cutout for new ignition coil high tension lead added</li> <li>• Cutout for stop switch lead added</li> </ul>	 <p>HIGH TENSION LEAD CUTOUT</p> <p>STOP SWITCH LEAD CUTOUT</p>	

**SUPPLEMENT Y (ADD GSV190)**

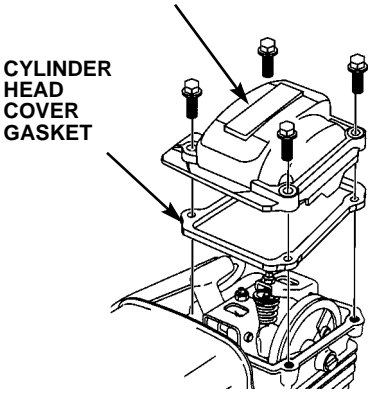
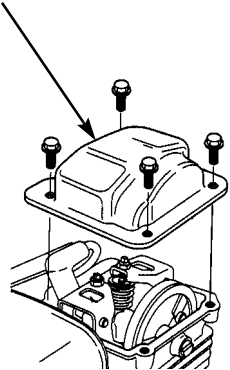
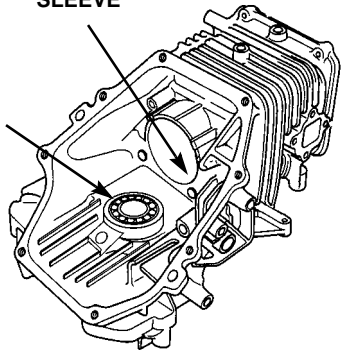
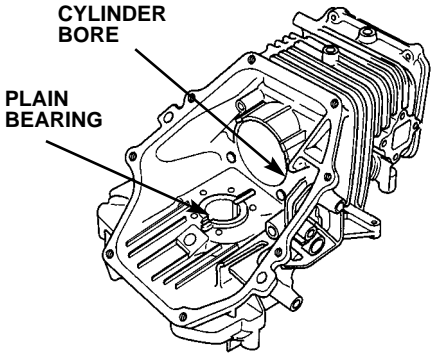
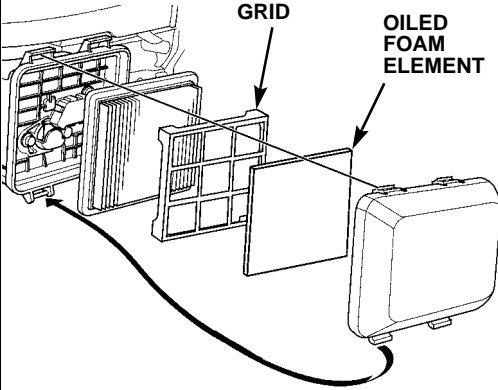
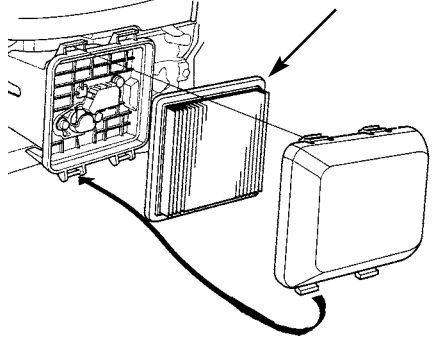
Item	Model	
	GSV190	GCV160 • GCV190
<p><b>CYLINDER HEAD COVER</b></p> <ul style="list-style-type: none"> <li>• Cast aluminum valve cover</li> <li>• Cylinder head cover gasket</li> </ul>	<p><b>CYLINDER HEAD COVER (cast aluminum)</b></p>  <p><b>CYLINDER HEAD COVER GASKET</b></p>	<p><b>CYLINDER HEAD COVER (stamped steel)</b></p> 
<p><b>BARREL ASSEMBLY</b></p> <ul style="list-style-type: none"> <li>• Ball bearing (flywheel side)</li> <li>• Cast-iron cylinder sleeve</li> </ul>	<p><b>CAST-IRON CYLINDER SLEEVE</b></p>  <p><b>BALL BEARING (flywheel side only)</b></p>	<p><b>ALUMINUM CYLINDER BORE</b></p>  <p><b>PLAIN BEARING</b></p>
<p><b>DUAL AIR CLEANER</b></p> <ul style="list-style-type: none"> <li>• Oiled foam element</li> <li>• Plastic grid added to separate foam element from the paper element</li> </ul>	 <p><b>PLASTIC GRID</b></p> <p><b>OILED FOAM ELEMENT</b></p>	 <p><b>PAPER ELEMENT ONLY</b></p>



**OUTLINE OF CHANGES**

**SUPPLEMENT X (ADD ELECTRIC START)**

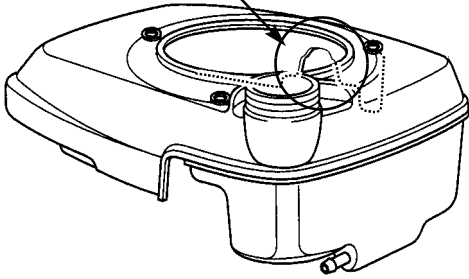
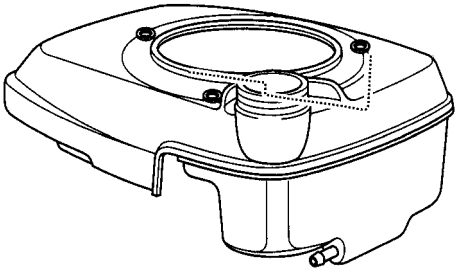
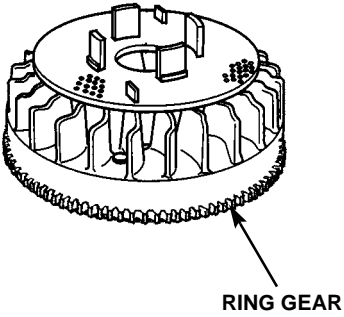
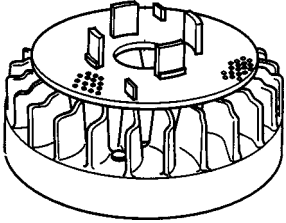
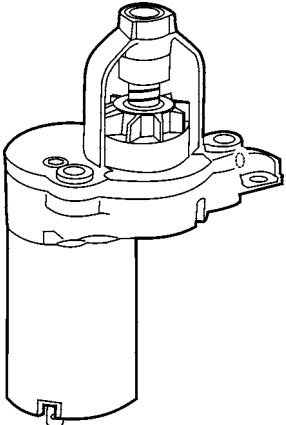
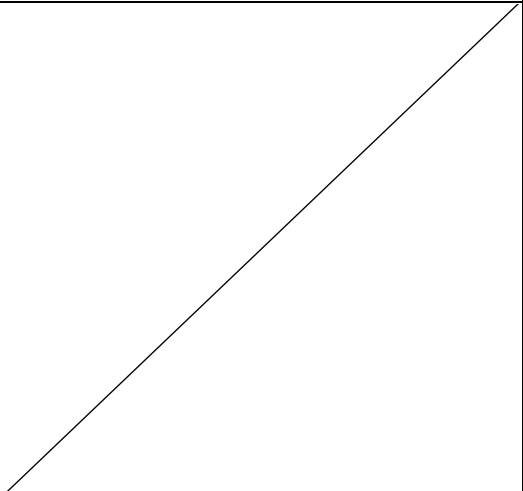
Item	Model	
	GCV160 ELECTRIC START	GCV160
<p><b>ENGINE COVER</b> Cut out to accept starter motor</p>	<p>AREA REMOVED FOR ELECTRIC STARTER MOTOR</p> 	
<p><b>FLYWHEEL</b> Ring gear part of the flywheel casting</p>	 <p>RING GEAR</p>	
<p><b>12VDC ELECTRIC STARTER</b></p>		

**OUTLINE OF CHANGES**

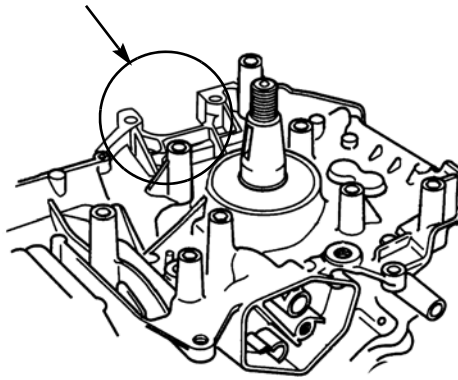
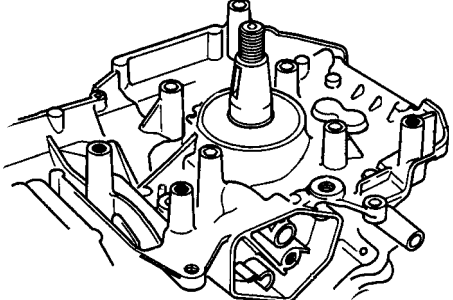
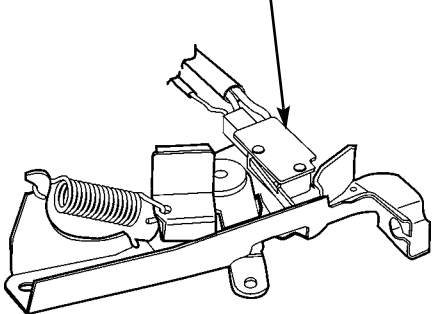
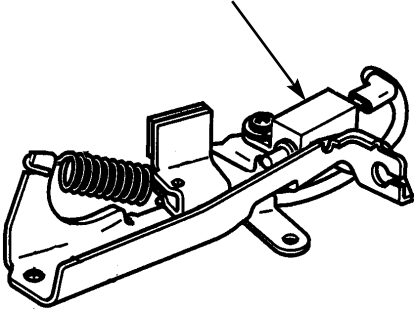
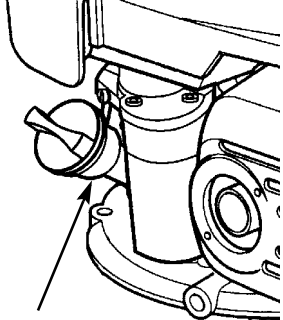
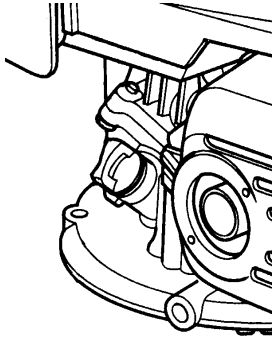
Item	Model	
	GCV160 ELECTRIC START	GCV160
<p><b>CYLINDER BARREL</b> Area changed to accept electric starter motor</p>	<p><b>STARTER MOTOR MOUNT AREA</b></p> 	
<p><b>FLYWHEEL BRAKE ASSEMBLY</b> Engine switch incorporated into brake assembly</p>	<p><b>SWITCH IS INCORPORATED WITH BRAKE ASSEMBLY</b></p> 	<p><b>REPLACEABLE SWITCH</b></p> 
<p><b>OIL FILLER EXTENSION</b> Oil filler extension added to clear starter motor</p>	 <p><b>OIL FILLER EXTENSION</b></p>	

# OUTLINE OF CHANGES

## SUPPLEMENT W (ADD ACS AUTO CHOKE)

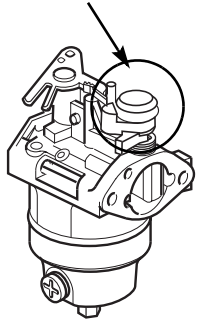
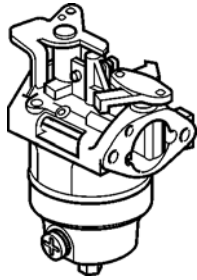
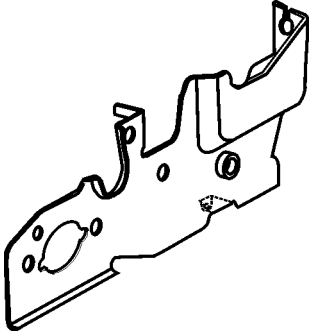
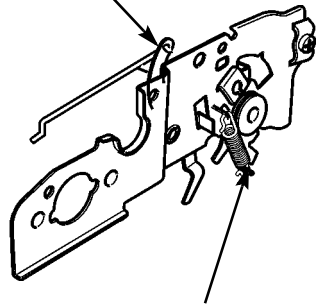
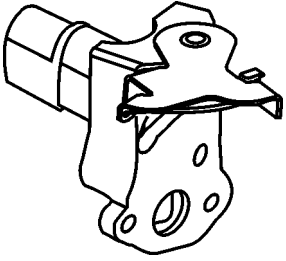
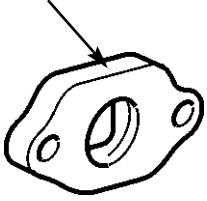
Item	Model	
	GCV160 • GCV190 AUTO CHOKE	GCV160 • GCV190
<b>CARBURETOR</b> <ul style="list-style-type: none"> <li>Choke arm changed to accept new choke control assembly actuating arm</li> </ul>	<p><b>CHOKE ARM</b></p> 	
<b>CONTROL BASE (FIXED THROTTLE TYPE)</b> <ul style="list-style-type: none"> <li>Choke and throttle control arms are not used</li> </ul>		<p><b>CHOKE CONTROL ARM</b></p>  <p><b>THROTTLE CONTROL ARM</b></p>
<b>CHOKE CONTROL ASSEMBLY</b> <ul style="list-style-type: none"> <li>Choke control assembly added to the carburetor insulator</li> </ul>		<p><b>CARBURETOR INSULATOR</b></p> 

**OUTLINE OF CHANGES**

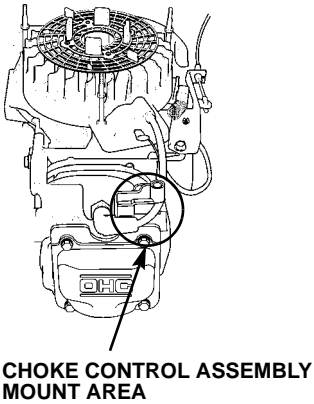
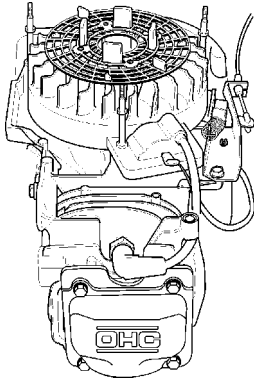
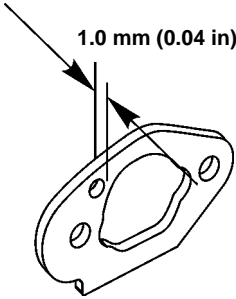
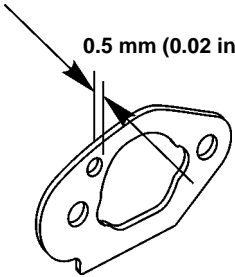
Item	Model	
	GCV160 • GCV190 AUTO CHOKE	GCV160 • GCV190
<p><b>CYLINDER BARREL</b></p> <ul style="list-style-type: none"> <li>• Area added to accept the choke control assembly</li> </ul>	 <p><b>CHOKE CONTROL ASSEMBLY MOUNT AREA</b></p>	
<p><b>CARBURETOR GASKET</b></p> <ul style="list-style-type: none"> <li>• Increase in thickness for auto-choke system</li> </ul>	 <p><b>1.0 mm (0.04 in)</b></p>	 <p><b>0.5 mm (0.02 in)</b></p>

# OUTLINE OF CHANGES

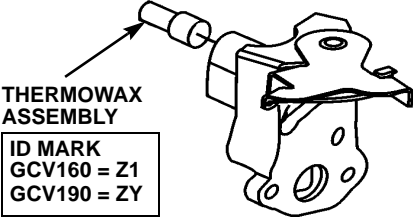
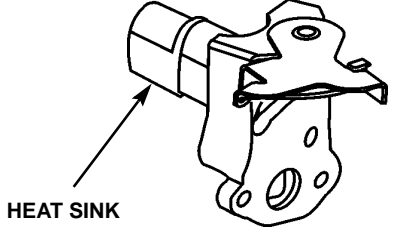
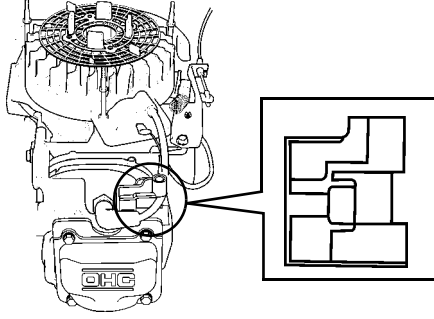
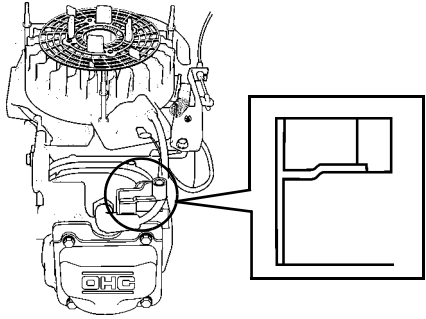
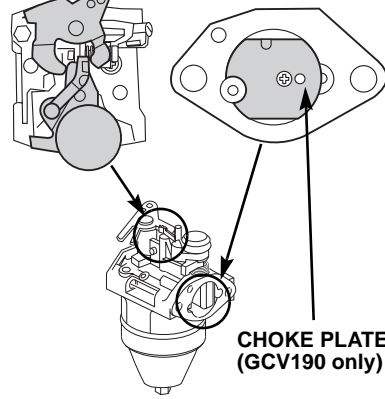
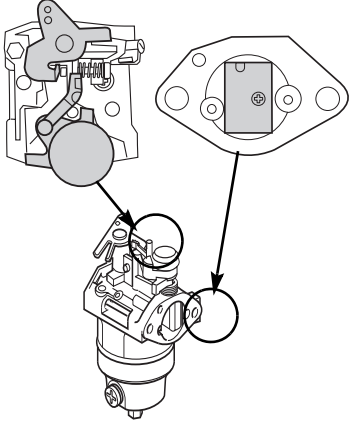
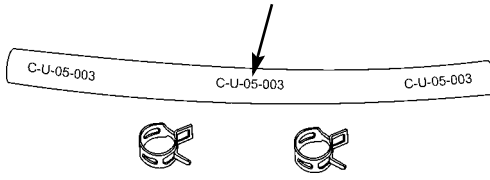
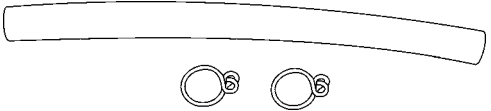
Item	Model	
	AUTO CHOKE (AFTER MODIFICATION)	AUTO CHOKE (BEFORE MODIFICATION)
<b>AUTO-CHOKE SYSTEM (ACS)</b> <ul style="list-style-type: none"> <li>Heat sink eliminated</li> <li>New thermowax assembly</li> </ul>	 <p><b>THERMOWAX ASSEMBLY</b> ID MARK GCV160 = Z1 GCV190 = ZY</p>	 <p><b>HEAT SINK</b></p>
<b>CYLINDER BARREL</b> <ul style="list-style-type: none"> <li>Heat sink integrated into cylinder barrel</li> </ul>		
<b>CARBURETOR</b> <ul style="list-style-type: none"> <li>Throttle and choke levers work together</li> <li>Choke plate changed (GCV190 only)</li> </ul>	 <p><b>CHOKE PLATE (GCV190 only)</b></p>	
<b>FUEL TUBE</b> <ul style="list-style-type: none"> <li>Low-permeable fuel line</li> <li>"D" style hose clamps</li> </ul>	<p><b>CARB EXECUTIVE ORDER</b></p> 	

**SUPPLEMENT U (ADD 2007 EMISSION CHANGES)**

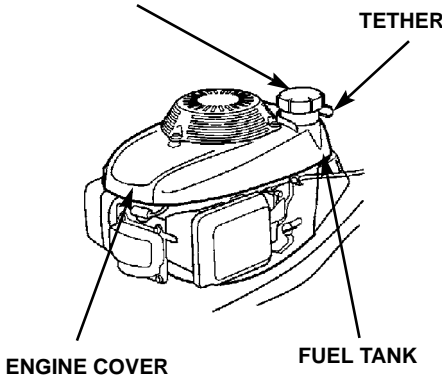
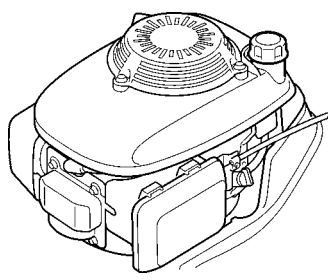
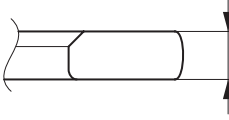
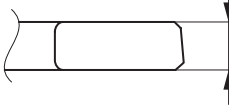
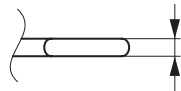
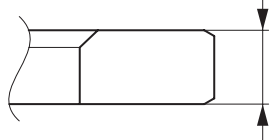
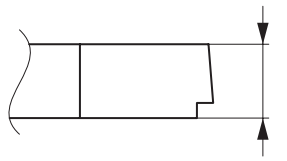

Item	Model	
	GCV160LA • GCV190LA • GSV190LA 2007 EMISSION COMPONENTS	GCV160 • GCV190 • GSV190
<p><b>ENGINE COVER/ GAS CAP</b></p> <ul style="list-style-type: none"> <li>Redesigned engine cover</li> <li>Fuel cap has a charcoal filter, tether, and ratchet mechanism</li> <li>Fuel tank is separate from the fan cover</li> </ul>	<p><b>GAS CAP/ EVAPORATIVE CANISTER</b></p> 	
<p><b>PISTON RINGS</b></p> <ul style="list-style-type: none"> <li>Thickness changed</li> <li>Material changed from cast-iron to steel</li> </ul>	<p><b>TOP RING:</b></p> <p>GCV160LA: 0.93 - 0.95 mm (0.036 - 0.037 in)</p> <p>GCV/GSV190LA: 0.95 - 0.97 mm (0.037 - 0.038 in)</p>  <p><b>SECOND RING:</b></p> <p>0.97 - 0.99 mm (0.038 - 0.039 in)</p>  <p><b>OIL RING (SIDE RAIL):</b></p> <p>0.390 - 0.420 mm (0.0154 - 0.0165 in)</p> 	<p><b>TOP RING:</b></p> <p>1.50 mm (0.06 in)</p>  <p><b>SECOND RING:</b></p> <p>1.50 mm (0.06 in)</p> 

# OUTLINE OF CHANGES

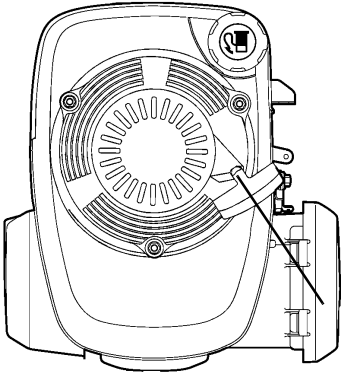
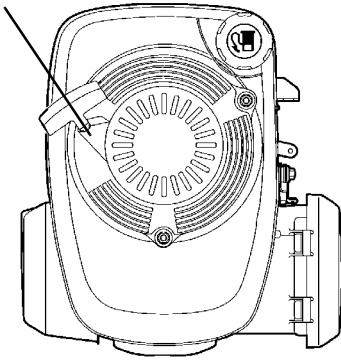
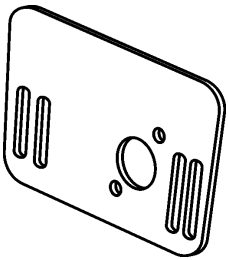
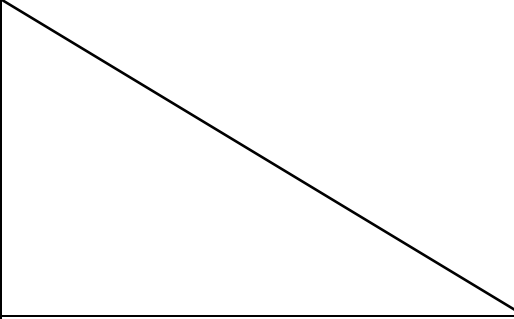
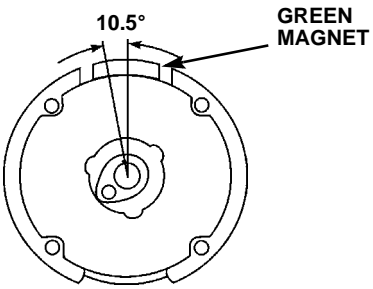
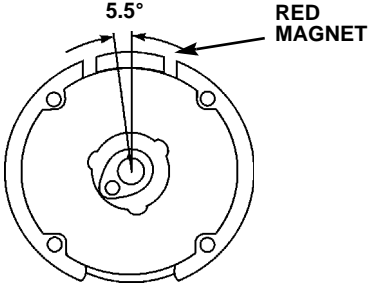
## SUPPLEMENT S (ADD GCV190 N5AP TYPE)

Item	Model	
	GCV190N5AP	GCV190
<p>RECOIL</p> <p>Recoil installed in the new position</p>		
<p>MUFFLER GASKET</p>		
<p>FLYWHEEL</p> <ul style="list-style-type: none"> <li>• Key angle changed 10.5°</li> <li>• Ignition timing changed to 25° BTDC</li> <li>• Identified by green magnet</li> </ul>		

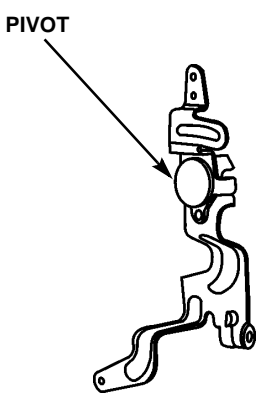
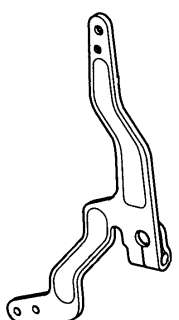
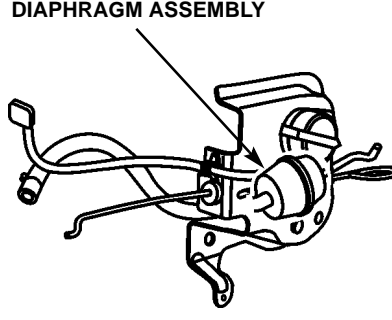
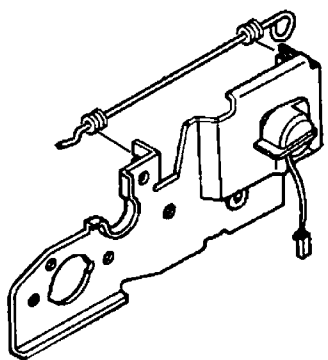
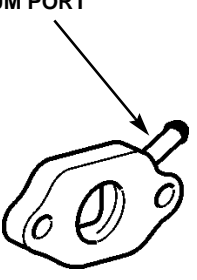
**SUPPLEMENT R (ADD GCV190 N5AV AUTO THROTTLE® TYPE)**

Item	Model	
	GCV190N5AV (AUTO THROTTLE®)	GCV190N5AP
<p>GOVERNOR ARM</p> <ul style="list-style-type: none"> <li>Pivot added</li> </ul>	<p>PIVOT</p> 	
<p>CONTROL BASE</p> <ul style="list-style-type: none"> <li>Diaphragm assembly added</li> </ul>	<p>DIAPHRAGM ASSEMBLY</p> 	
<p>INSULATOR</p> <ul style="list-style-type: none"> <li>Vacuum port added</li> </ul>	<p>VACUUM PORT</p> 	



## OUTLINE OF CHANGES

---

# 1. SPECIFICATIONS

1. SPECIFICATIONS.....	1-1	4. DIMENSIONAL DRAWINGS .....	1-6
2. DIMENSIONS AND WEIGHTS .....	1-3	5. PTO DIMENSIONAL DRAWINGS .....	1-10
3. PERFORMANCE CURVES.....	1-4	6. WIRING DIAGRAMS.....	1-13

## 1. SPECIFICATIONS

### • GCV135/GCV160

Model	GCV135	GCV160
Type	4-stroke, overhead camshaft single cylinder	
Displacement	135 cc (8.2 cu-in)	160 cc (9.8 cu-in)
Bore x stroke	64 x 42 mm (2.5 x 1.7 in)	64 x 50 mm (2.5 x 2.0 in)
Net power * (in accordance with SAE J1349)	2.7 kW (3.6 hp) at 3,600 rpm	3.4 kW (4.6 hp) at 3,600 rpm
Max net torque * (in accordance with SAE J1349)	7.4 N•m (5.5 lbf•ft) at 2,500 rpm	9.4 N•m (6.9 lbf•ft) at 2,500 rpm
Compression ratio	8.5 : 1	
Cooling system	Forced-air	
Ignition system	Transistorized magneto ignition	
Ignition timing	20° B.T.D.C	
Spark plug	Pressure washer applications: BPR6ES All others: BPR5ES	
Carburetor	Horizontal type, butterfly valve	
Governor	Centrifugal mechanical governor	
Lubrication system	Splash	
Oil capacity	0.58 ℓ. (0.61 US qt, 0.55 Imp qt)	
Recommended operating ambient temperature	-5°C ~ 40°C (23°F ~ 104°F)	
Starting system	Recoil starter	Recoil starter and 12 Vdc electric starter motor
Stopping system	Ignition primary circuit ground	
Fuel used	Unleaded gasoline with a pump octane number 86 or higher	
Fuel tank capacity	1.3 ℓ (0.34 US gal)	1.8 ℓ (0.48 US gal)
Fuel consumption (approximate)‡	0.95 liter/hr (0.25 US gal/hr)	1.1 liter/hr (0.29 US gal/hr)
PTO shaft rotation	Counterclockwise (from PTO shaft side)	
Noise level	76 dBA at 7m	

\* The power rating of the engine indicated in this document is the net power output tested on a production engine for the engine model and measured in accordance with SAE J1349 at 3,600 rpm (net power) and 2,500 rpm (max. net torque). Mass production engines may vary from this value. Actual power output for the engine installed in the final machine will vary depending on numerous factors, including the operating speed of the engine in application environmental conditions, maintenance, and other variables.

‡ Actual consumption will vary depending on the load applied to the engine.

## SPECIFICATIONS

### • GCV190/GSV190

Type	4-stroke, overhead camshaft single cylinder
Displacement	187 cc (11.4 cu-in)
Bore x stroke	69 x 50 mm (2.7 x 2.0 in)
Net power * (in accordance with SAE J1349)	3.8 kW (5.1 HP) at 3,600 rpm
Max net torque * (in accordance with SAE J1349)	11.3 N•m (8.3 lb-ft) at 2,500 rpm
Compression ratio	8.5 : 1
Cooling system	Forced-air
Ignition system	Transistorized magneto ignition
Ignition timing	All others: 20° B.T.D.C. GCV190N5AP: 25° B.T.D.C.
Spark plug	Pressure washer applications: BPR6ES All others: BPR5ES
Carburetor	Horizontal type, butterfly valve
Governor	Centrifugal mechanical governor
Lubrication system	Splash
Oil capacity	0.55 ℓ. (0.58 US qt, 0.48 Imp qt)
Recommended operating ambient temperature	-5°C ~ 40°C (23°F ~ 104°F)
Starting system	Recoil starter
Stopping system	Ignition primary circuit ground
Fuel used	Unleaded gasoline with a pump octane number 86 or higher
Fuel tank capacity	0.93 ℓ (0.98 US qt)
Fuel consumption (approximate)‡	1.3 liter/hr (0.34 US gal/hr)
PTO shaft rotation	Counterclockwise (from PTO shaft side)
Noise level	76 dBA at 7m

\* The power rating of the engine indicated in this document is the net power output tested on a production engine for the engine model and measured in accordance with SAE J1349 at 3,600 rpm (net power) and 2,500 rpm (max. net torque). Mass production engines may vary from this value. Actual power output for the engine installed in the final machine will vary depending on numerous factors, including the operating speed of the engine in application environmental conditions, maintenance, and other variables.

‡ Actual consumption will vary depending on the load applied to the engine.

## 2. DIMENSIONS AND WEIGHTS

- **GCV135/160**

Item	PTO type	N1	N2
Overall length		351 mm (13.8 in)	
Overall width		331 mm (13.0 in)	
Overall height		353 mm (13.9 in)	340 mm (13.4 in)
Dry weight		9.5 kg (20.9 lb)	
Operating weight		10.8 kg (23.8 lb)	

Item	PTO type	E1AE (electric start types [GCV160 only])
Overall length		370.5 mm (14.6 in)
Overall width		354 mm (13.9 in)
Overall height		368 mm (14.5 in)
Dry weight		11.6 kg (25.6 lb)
Operating weight		12.8 kg (28.2 lb)

- **GCV190**

Item	PTO type	N1	N2
Overall length		367 mm (14.4 in)	
Overall width		331 mm (13.0 in)	
Overall height		368 mm (14.5 in)	349 mm (13.7 in)
Dry weight		12.5 kg (27.6 lb)	
Operating weight		13.6 kg (30.4 lb)	

- **GSV190**

Item	PTO type	N1	N2	N3	N4	N5
Overall length		370.5 mm (14.6 in)	370.5 mm (14.6 in)	370.5 mm (14.6 in)	370.5 mm (14.6 in)	370.5 mm (14.6 in)
Overall width		342.5 mm (13.5 in)	342.5 mm (13.5 in)	342.5 mm (13.5 in)	342.5 mm (13.5 in)	342.5 mm (13.5 in)
Overall height		368 mm (14.5 in)	349 mm (13.7 in)	368 mm (14.5 in)	349 mm (13.7 in)	366 mm (13.7 in)
Dry weight		11.2 kg (24.7 lb)	11.2 kg (24.7 lb)	11.2 kg (24.7 lb)	12.3 kg (27.1 lb)	12.3 kg (27.1 lb)
Operating weight		12.5 kg (27.6 lb)	12.5 kg (27.6 lb)	12.5 kg (27.6 lb)	13.6 kg (30.0 lb)	13.6 kg (30.0 lb)

# SPECIFICATIONS

## 3. PERFORMANCE CURVES

- GCV135/GCV160

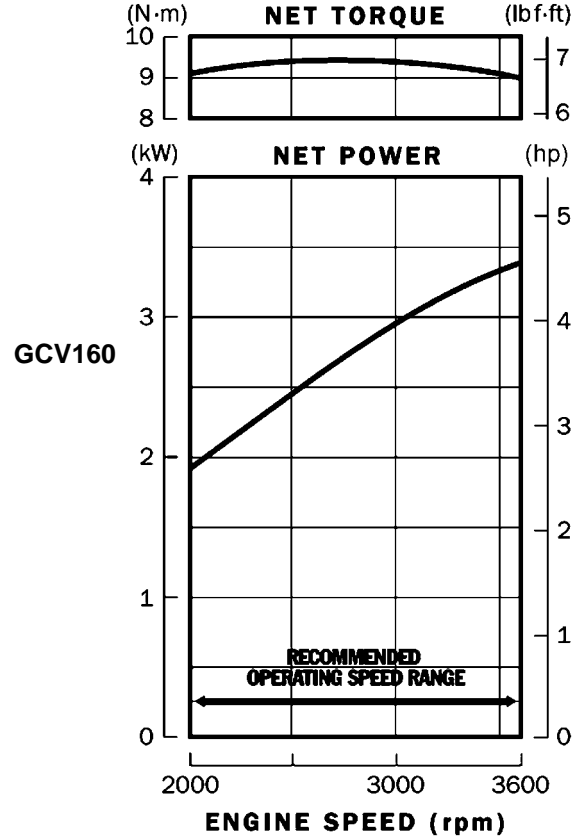
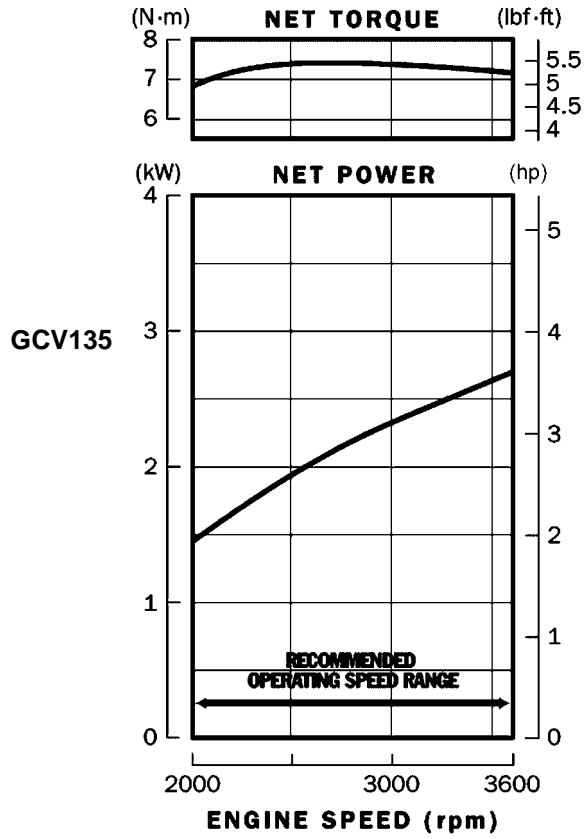

• GCV190/GSV190

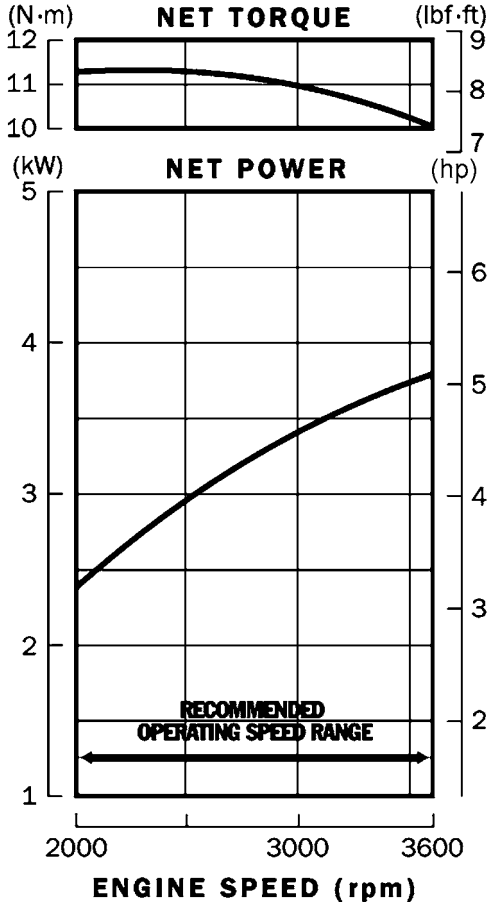

# SPECIFICATIONS

## 4. DIMENSIONAL DRAWINGS

• GCV135/GCV160

[ ]: GCV135

Unit: mm (in)

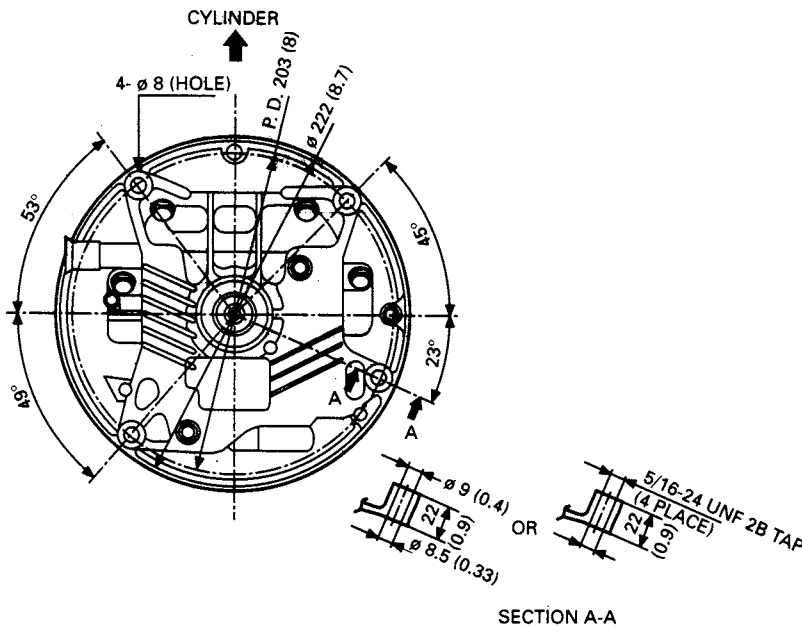
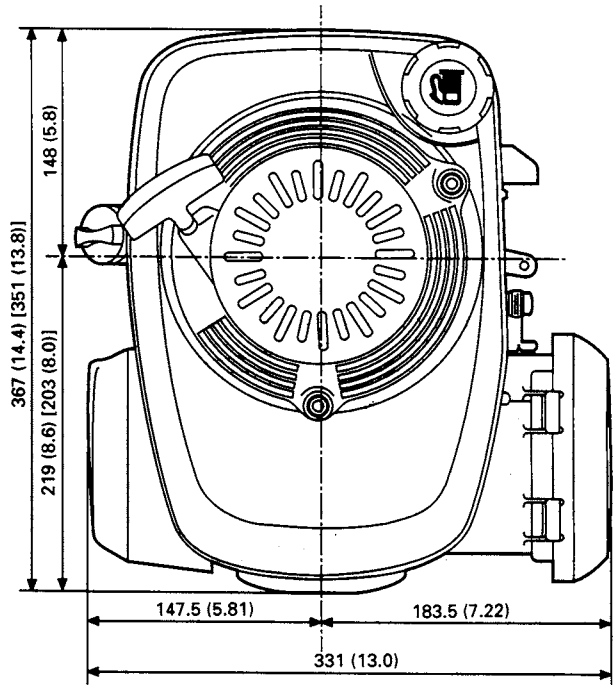
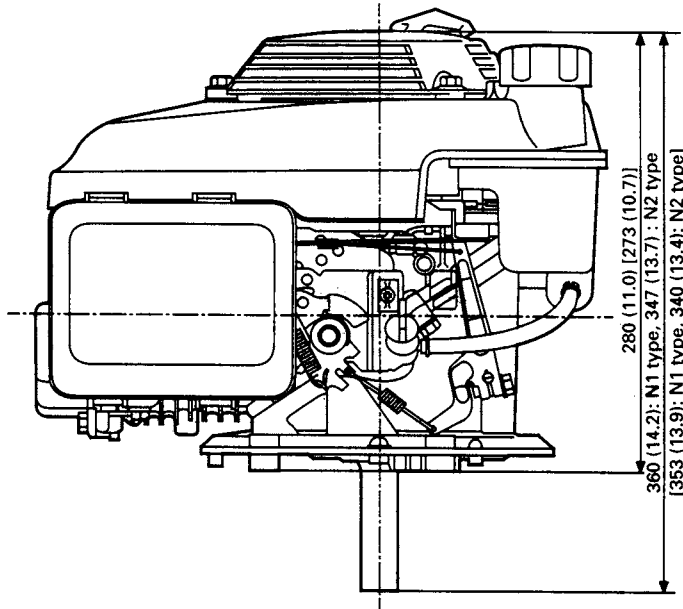

**SPECIFICATIONS**

• GCV190/GSV190

Unit: mm (in)

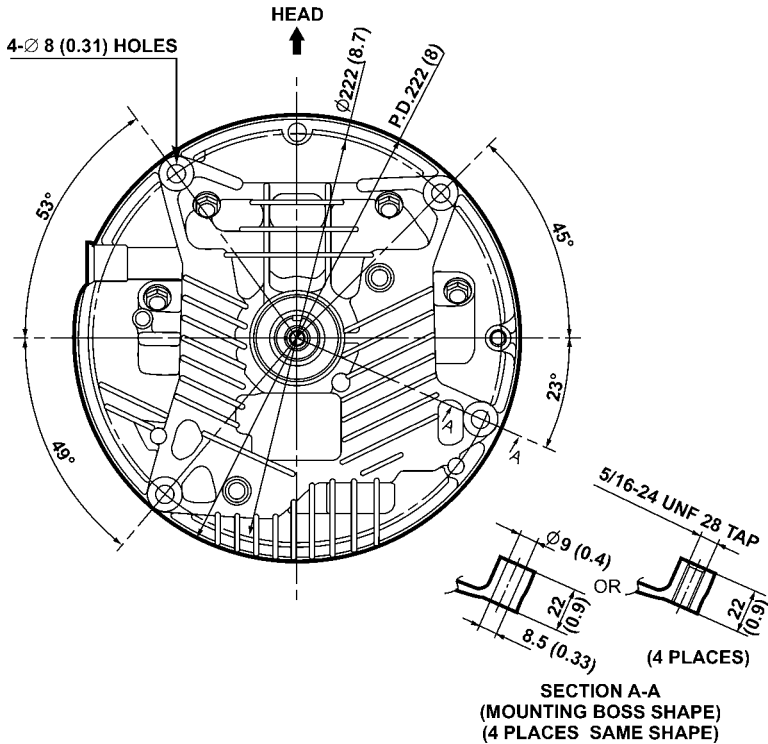
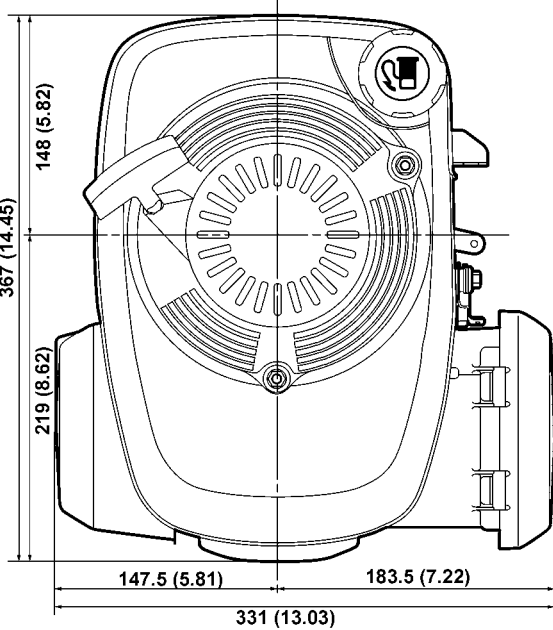
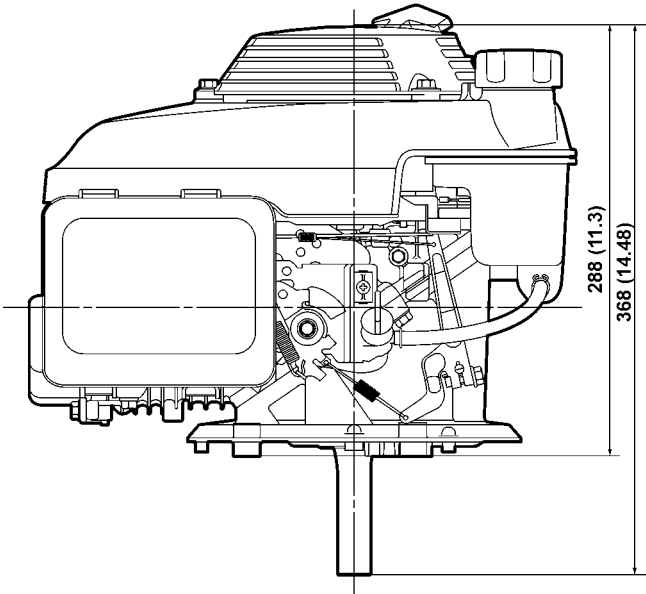



# SPECIFICATIONS

---

- ELECTRIC START TYPES (GCV160/GCV190)

Units: mm (in)

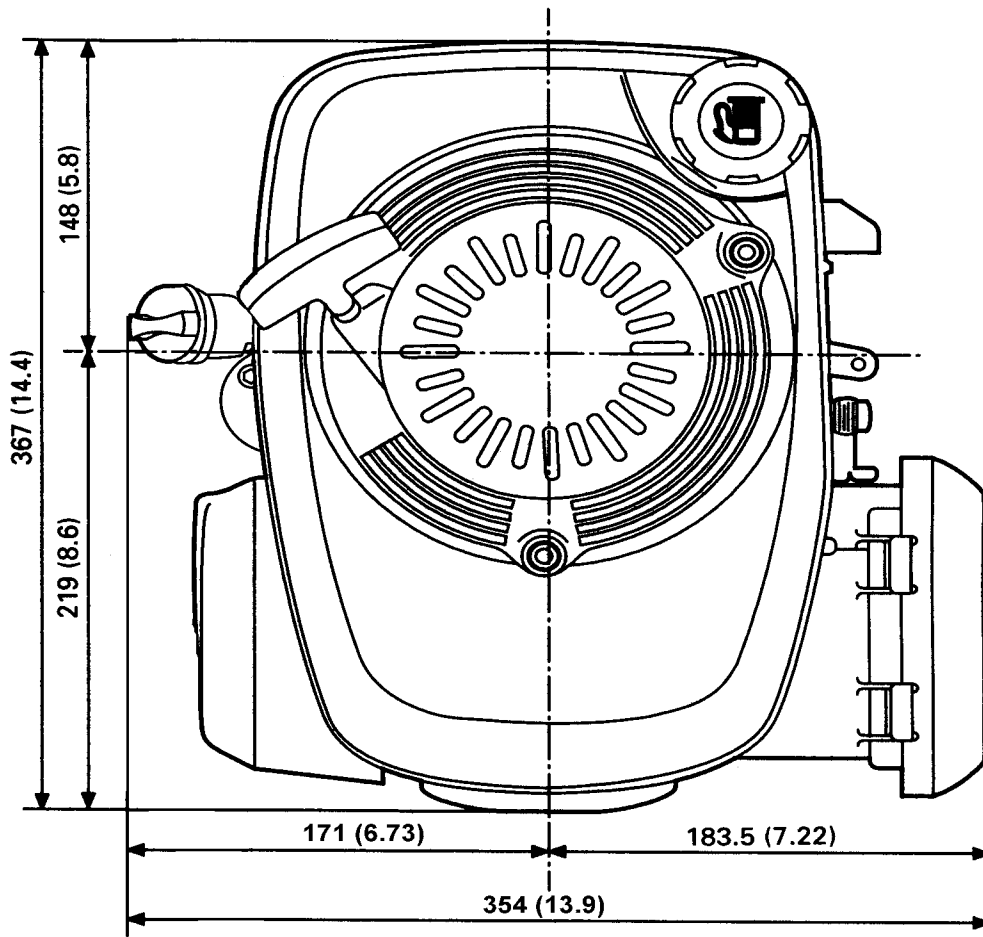

**• GCV160LA/GCV190LA/GSV190LA TYPES  
(SEPARATE FUEL TANK/EVAPORATIVE CANISTER GAS CAP)**

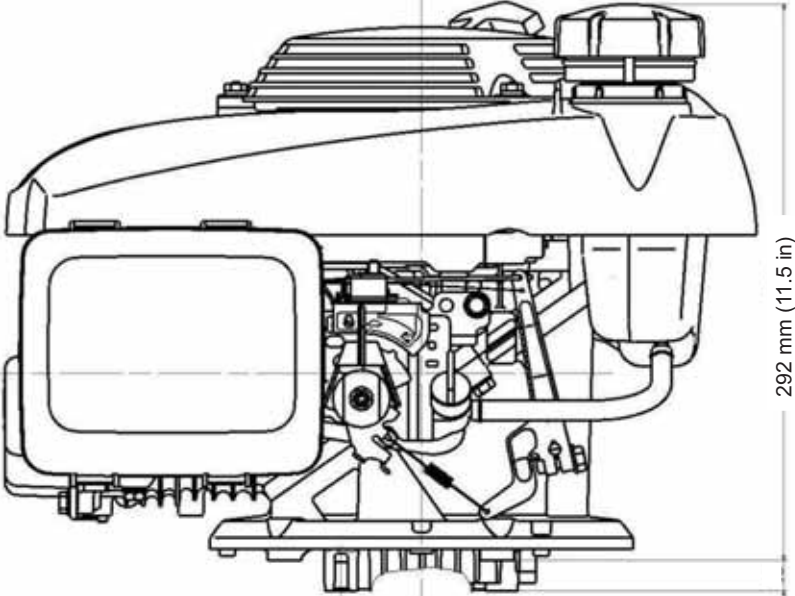
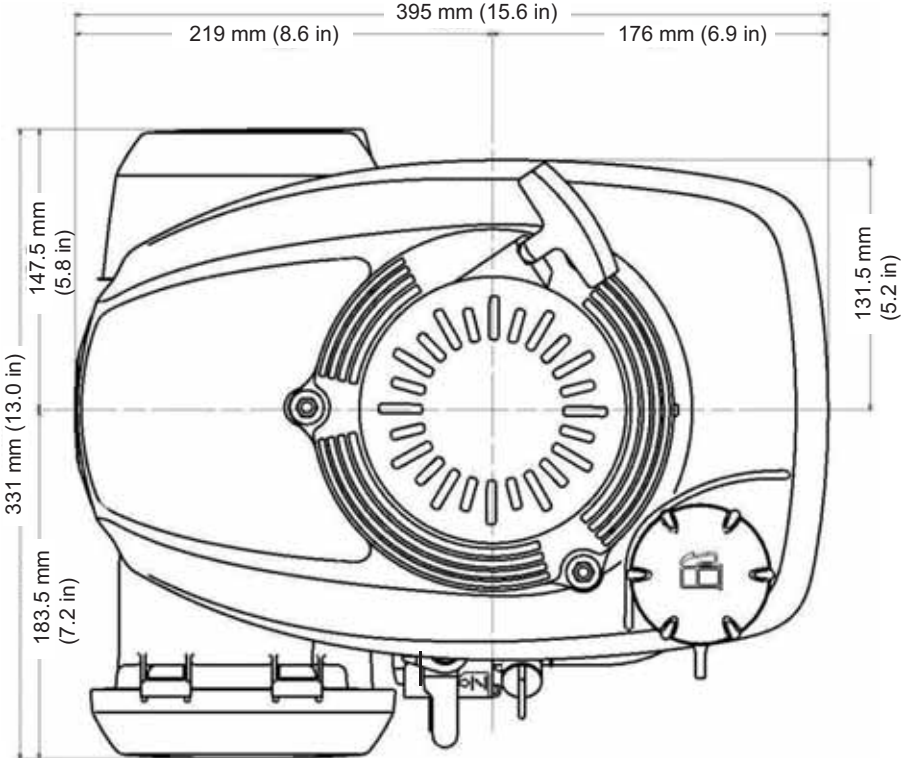

16 mm  
(0.6 in)

# SPECIFICATIONS

## 5. PTO DIMENSIONAL DRAWINGS

• GCV135/GCV160

Unit: mm (in)

### N1 type

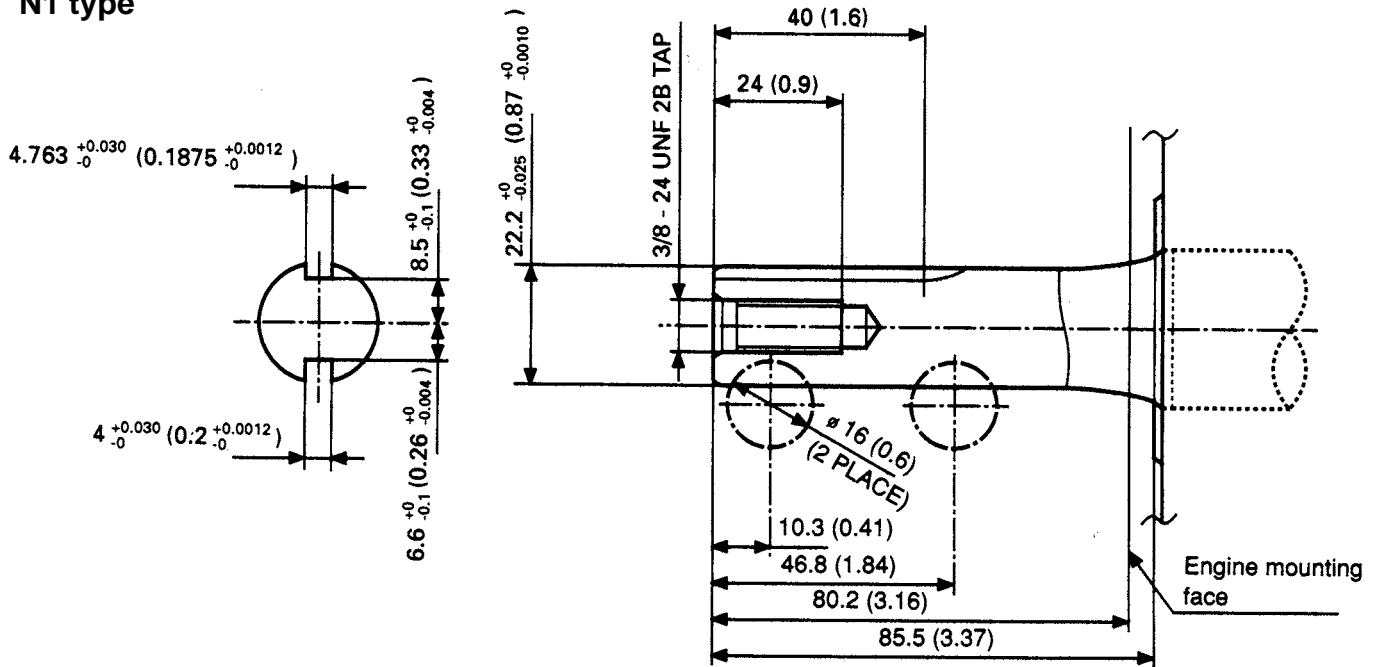

### N2 type

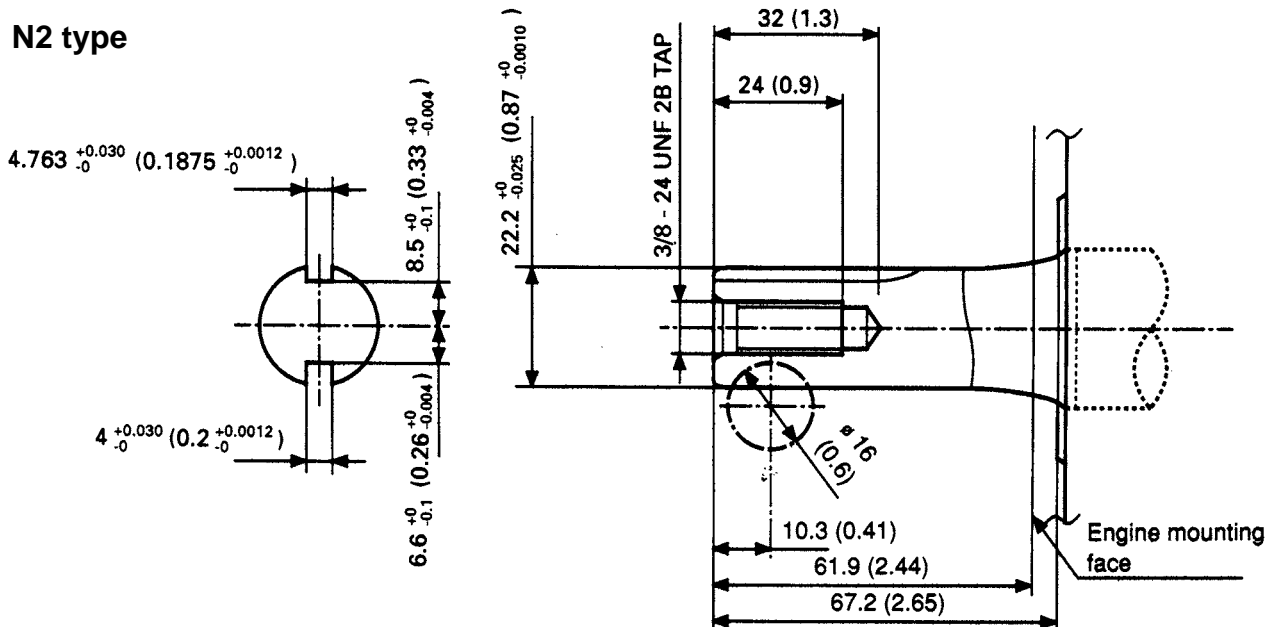

• GCV190

Unit: mm (in)

N3 type

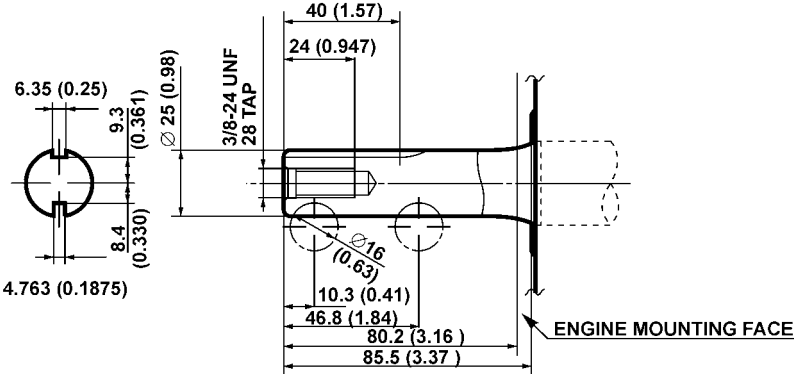

N4 type

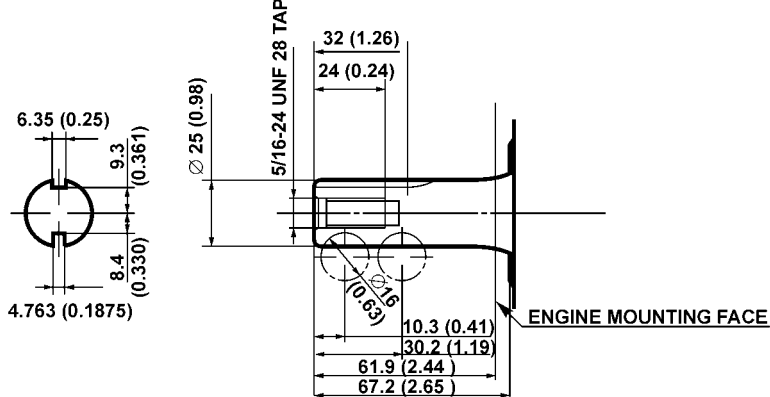

N5 type

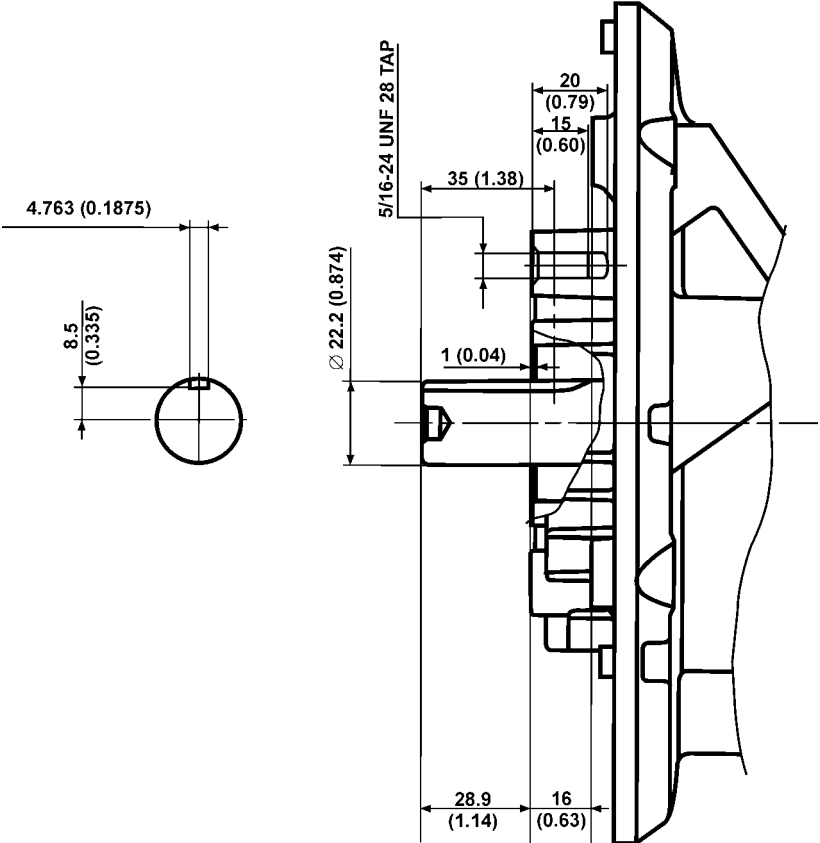

# SPECIFICATIONS

---

- BHH TYPE (BLADE-BRAKE CLUTCH TYPES)

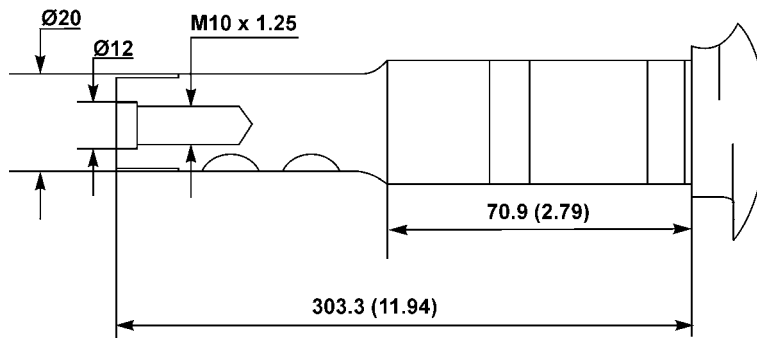

## 6. WIRING DIAGRAMS

• GCV135/160/190/GSV190

WITH FLYWHEEL BRAKE

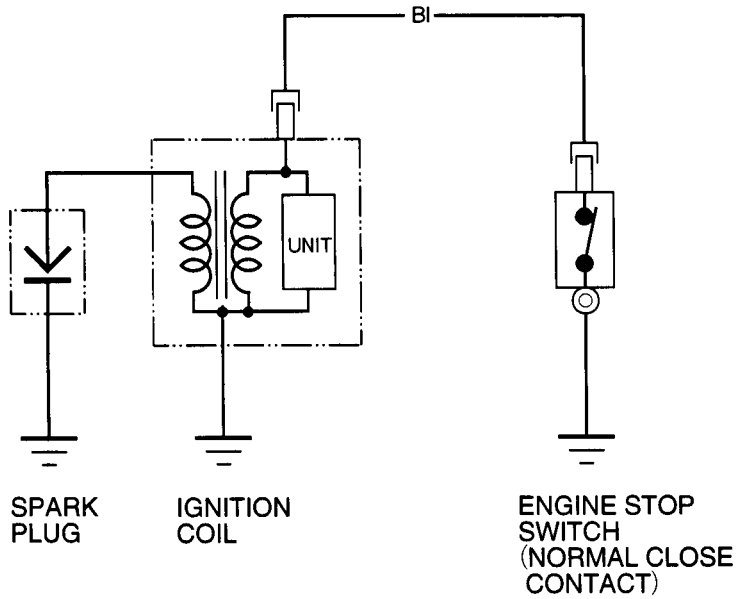

Bl	Black	Br	Brown
Y	Yellow	O	Orange
Bu	Blue	Lb	Light blue
G	Green	Lg	Light green
R	Red	P	Pink
W	White	Gr	Gray

ENGINE	SWITCH CONTACT
RUN	OPEN
STOP	CLOSE

WITHOUT FLYWHEEL BRAKE

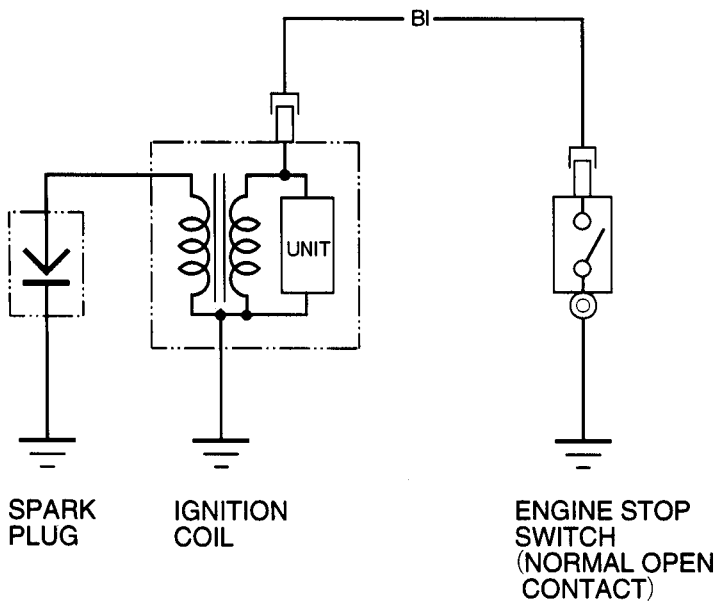

Bl	Black	Br	Brown
Y	Yellow	O	Orange
Bu	Blue	Lb	Light blue
G	Green	Lg	Light green
R	Red	P	Pink
W	White	Gr	Gray

ENGINE	SWITCH CONTACT
RUN	OPEN
STOP	CLOSE

# SPECIFICATIONS

---

- ELECTRIC START TYPES

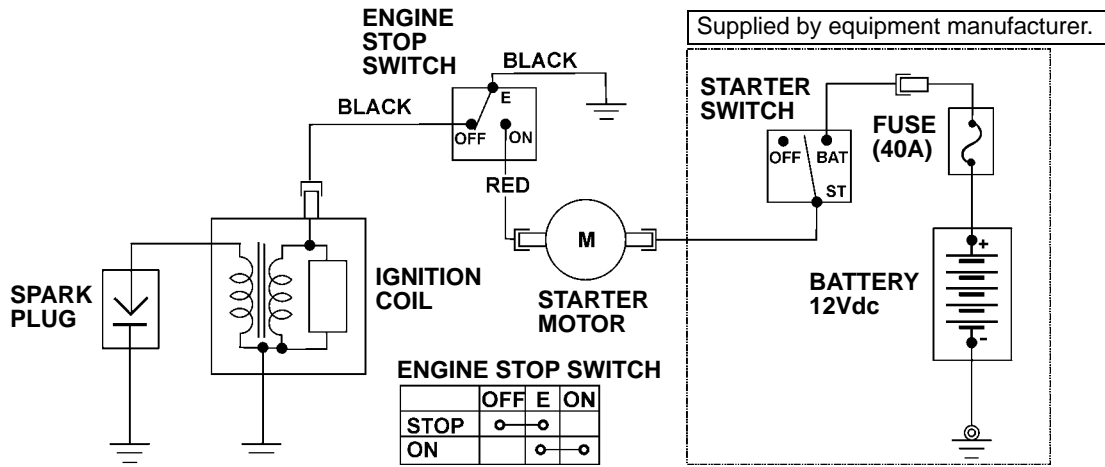

# 2. SERVICE INFORMATION

1. SERVICE RULES . . . . .	2-1	5. TORQUE VALUES . . . . .	2-7
2. SYMBOLS USED IN THIS MANUAL . . . . .	2-1	6. TOOLS . . . . .	2-8
3. SERIAL NUMBER LOCATIONS . . . . .	2-2	7. TROUBLESHOOTING . . . . .	2-10
4. SERVICE SPECIFICATIONS . . . . .	2-3	8. HARNESS ROUTING . . . . .	2-31

## 1. SERVICE RULES

- Use Honda Genuine parts or their exact equivalent. Lower quality parts can damage the engine or reduce its performance.
- Install new gaskets, O-rings, and seals during reassembly.
- This mower uses metric fasteners and SAE (nonmetric) fasteners. Metric bolts, nuts, and screws are not interchangeable with nonmetric fasteners. The use of incorrect tools and fasteners may damage the engine.
- When tightening nuts and bolts, begin with the larger-diameter or inner bolts, and tighten diagonally to the specified torque values, unless a particular tightening sequence is specified.
- When tightening self-tapping screws, be especially careful to avoid cross-threading or overtightening.
- Clean parts in nonflammable solvent after disassembly.
- Lubricate sliding surfaces before reassembly.
- After reassembly, check parts installation and operation.

## 2. SYMBOLS USED IN THIS MANUAL

As you read this manual, you may find the following symbols with the instructions.



A special tool is required to perform the procedure.

(commercially available)

There are two convenient ways to order: online or by toll-free phone.

- To order online, go to the iN: SERVICE>Tools>Tool and Equipment Program>Online Catalog, and then search by model number.
- To order by phone, call 1-888-424-6857.  
Customer service representatives are available from 7:30 AM until 7:00 PM CT, Monday through Friday.



Apply grease



Apply oil

O x O ( O )      Indicates the diameter, length, and quantity of metric flange bolts used.

P. O-O      Indicates the reference page.



## SERVICE INFORMATION

---

### 3. SERIAL NUMBER LOCATIONS

The engine serial number and type variation are located on the cylinder block near the muffler. Refer to the engine serial number and type variation when ordering parts and when making technical inquiries.

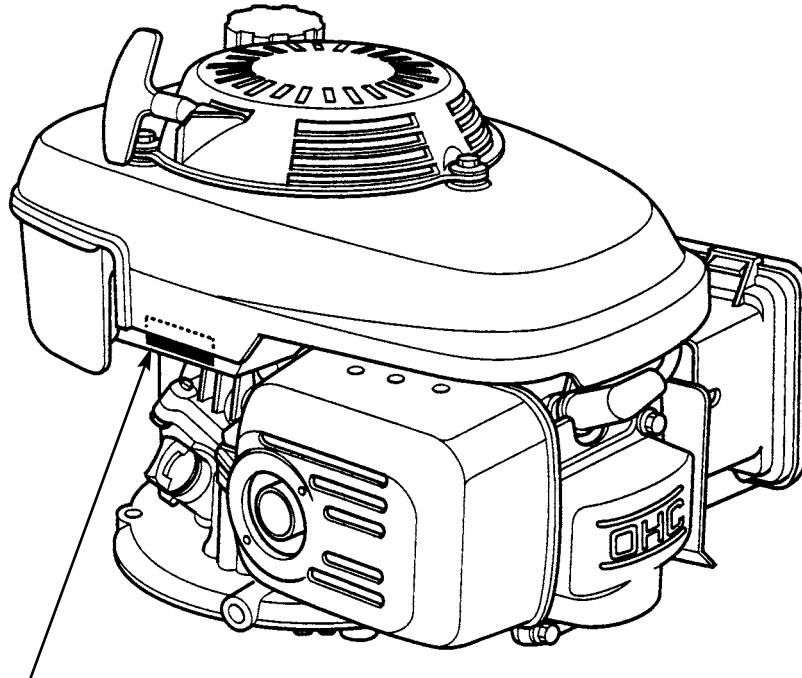

ENGINE SERIAL NUMBER AND TYPE VARIATION

## 4. SERVICE SPECIFICATIONS

• **GCV135/GCV160**

PART	ITEM	STANDARD	SERVICE LIMIT	
Engine	Maximum governed speed	Lawn mowers: 2,950 ~ 3,100 rpm All others: 2,950 ~ 3,250 rpm	----- ----- -----	
	Idle speed	1,700 ± 150 rpm		
	Cylinder compression	490 kPa (5.0 kg/cm <sup>2</sup> , 71 psi) at 600 rpm		
Carburetor (See <a href="#">P. 2-5</a> for specifications by Carburetor ID)				
Spark plug	Gap	0.7 ~ 0.8 mm (0.028 ~ 0.031 in)	-----	
Valves	Valve clearance (cold)	IN 0.15 ± 0.04 mm EX 0.20 ± 0.04 mm	----- -----	
	Stem OD	IN 5.48 mm (0.216 in) EX 5.44 mm (0.214 in)	5.318 mm (0.2094 in) 5.275 mm (0.2077 in)	
	Guide ID	IN/EX 5.50 mm (0.217 in)	5.572 mm (0.2194 in)	
	Seat width	IN/EX 0.7 mm (0.028 in)	1.8 mm (0.07 in)	
	Spring free length	IN/EX 30.5 mm (1.20 in)	29.0 mm (1.14 in)	
	Piston	Skirt OD	63.969 mm (2.5185 in)	63.829 mm (2.5129 in)
Piston-to-cylinder clearance		0.031 ~ 0.070 mm (0.0012 ~ 0.0028 in)	0.12 mm (0.005 in)	
Piston pin bore ID		13.002 mm (0.5119 in)	13.048 mm (0.5137 in)	
Pin OD		13.000 mm (0.5118 in)	12.954 mm (0.5100 in)	
Piston rings	Ring width	Top/Second 1.5 mm (0.06 in) Oil 2.5 mm (0.10 in)	1.37 mm (0.054 in) 2.37 mm (0.093 in)	
	Ring side clearance	Top/Second/Oil 0.015 ~ 0.045 mm (0.0006 ~ 0.0018 in)	0.15 mm (0.006 in)	
	Ring end gap	Top 0.20 ~ 0.35 mm (0.008 ~ 0.014 in) Second 0.30 ~ 0.45 mm (0.012 ~ 0.018 in) Oil 0.015 ~ 0.035 mm (0.0006 ~ 0.0014 in)	1.0 mm (0.04 in) 1.0 mm (0.04 in) 1.0 mm (0.04 in)	
	Cylinder	Sleeve ID	64.000 mm (2.52 in)	64.165 mm (2.5262 in)
		Connecting rod	Small end ID	13.005 mm (0.5120 in)
Big end ID	26.02 mm (1.024 in)		26.066 mm (1.0262 in)	
Big end oil clearance	0.040 ~ 0.063 mm (0.0016 ~ 0.0025 in)		0.12 mm (0.005 in)	
Big end axial clearance	0.1 ~ 0.4 mm (0.004 ~ 0.016 in)		0.8 mm (0.031 in)	
Crankshaft	Main journal OD	PTO side 27.993 mm (1.1021 in) Flywheel side 25.393 mm (0.9997 in)	27.933 mm (1.0997 in) 25.333 mm (0.9974 in)	
	Crank pin OD	29.980 mm (1.1803 in)	29.92 mm (1.1780 in)	
	Cylinder block	Main journal ID	25.420 mm (1.0008 in)	25.466 mm (1.0026 in)
Crankshaft axial clearance		0.15 ~ 0.75 mm (0.006 ~ 0.030 in)	1.0 mm (0.04 in)	
Oil pan	Main journal ID	28.020 mm (1.1031 in)	28.066 mm (1.1050 in)	
Cam pulley	Cam lobe height	37.394 mm (1.4722 in)	37.369 mm (1.4712 in)	
	Cam pulley ID (bearing)	10.027 mm (0.3948 in)	10.075 mm (0.3967 in)	
	Cam pulley shaft OD	9.987 mm (0.3932 in)	9.920 mm (0.3906 in)	
Rocker arm	Rocker arm ID	6.000 mm (0.2362 in)	6.043 mm (0.2379 in)	
	Rocker arm shaft OD	5.990 mm (0.2358 in)	5.953 mm (0.2344 in)	
	Rocker arm shaft bearing ID	6.000 mm (0.2362 in)	6.043 mm (0.2379 in)	
Ignition coil (aluminum flywheel type)	Resistance	Primary coil 1.0 ~ 1.2 Ω Secondary coil 10.6 ~ 12.8 kΩ	----- -----	
	Air gap (at flywheel)	0.2 ~ 0.6 mm (0.008 ~ 0.024 in)	-----	
	Ignition coil (cast-iron flywheel type)	Resistance	Primary coil 0.68 ~ 0.84 Ω Secondary coil 5.6 ~ 6.9 kΩ	----- -----
Air gap (at flywheel)		0.2 ~ 0.5 mm (0.008 ~ 0.020 in)	-----	
Flywheel brake		Brake shoe thickness	6 mm (0.24 in)	3.0 mm (0.12 in)

## SERVICE INFORMATION

### • GCV190/GSV190

PART	ITEM	STANDARD	SERVICE LIMIT	
Engine (All except GCV190N5AV)	Maximum governed speed	2,950 ~ 3,250 rpm	-----	
	Idle speed	1,700 ± 150 rpm	-----	
	Cylinder compression	490 kPa (5.0 kg/cm <sup>2</sup> , 71 psi) at 600 rpm	-----	
GCV190N5AV	Maximum governed speed	3650 rpm maximum (loaded) 3,650 ~ 3,850 rpm (unloaded with diaphragm disabled)	-----	
	Idle speed	2350 rpm minimum	-----	
Carburetor (See <a href="#">P. 2-5</a> for specifications by Carburetor ID)				
Spark plug	Gap	0.7 ~ 0.8 mm (0.028 ~ 0.031 in)	-----	
Valves	Valve clearance (cold)	IN 0.15 ± 0.04 mm EX 0.20 ± 0.04 mm	-----	
	Stem OD	IN 5.48 mm (0.216 in) EX 5.44 mm (0.214 in)	5.318 mm (0.2094 in) 5.275 mm (0.2077 in)	
	Guide ID	IN/EX 5.50 mm (0.217 in)	5.572 mm (0.2194 in)	
	Seat width	IN/EX 0.7 mm (0.028 in)	1.8 mm (0.07 in)	
	Spring free length	IN/EX 30.5 mm (1.20 in)	29.0 mm (1.14 in)	
	Piston	Skirt OD	68.985 mm (2.7159 in)	68.885 mm (2.7120 in)
Piston-to-cylinder clearance		0.015 - 0.054 mm (0.0492 - 0.1772 in)	0.12 mm (0.005 in)	
Piston pin bore ID		13.002 mm (0.5119 in)	13.048 mm (0.5137 in)	
Pin OD		13.000 mm (0.5118 in)	12.954 mm (0.5100 in)	
Piston rings	Ring width	Top/Second 1.5 mm (0.06 in) Oil 2.5 mm (0.10 in)	1.37 mm (0.054 in) 2.37 mm (0.093 in)	
	Ring side clearance	Top 0.035 - 0.065 mm (0.0013 - 0.0026 in) Second 0.015 - 0.049 mm (0.0006 - 0.0019 in)	0.15 mm (0.006 in) 0.15 mm (0.006 in)	
	Ring end gap	Top 0.30 ~ 0.45 mm (0.012 ~ 0.018 in) Second 0.015 ~ 0.035 mm (0.0006 ~ 0.0014 in)	1.0 mm (0.04 in) 1.0 mm (0.04 in)	
	Cylinder	Sleeve ID	69.000 mm (2.7165 in)	69.165 mm (2.7230 in)
		Connecting rod	Small end ID	30.02 mm (1.1819 in)
Big end ID	26.02 mm (1.024 in)		26.066 mm (1.0262 in)	
Big end oil clearance	0.040 ~ 0.063 mm (0.0016 ~ 0.0025 in)		0.12 mm (0.005 in)	
Big end axial clearance	0.1 ~ 0.4 mm (0.004 ~ 0.016 in)		0.8 mm (0.031 in)	
Crankshaft	Main journal OD	PTO side 27.993 mm (1.1021 in) Flywheel side 25.393 mm (0.9997 in)	27.933 mm (1.0997 in) 25.333 mm (0.9974 in)	
	Crank pin OD	29.980 mm (1.1803 in)	29.92 mm (1.1780 in)	
	Cylinder block	Main journal ID	25.420 mm (1.0008 in)	25.466 mm (1.0026 in)
Crankshaft axial clearance		0.15 ~ 0.75 mm (0.006 ~ 0.030 in)	1.0 mm (0.04 in)	
Oil pan	Main journal ID	28.020 mm (1.1031 in)	28.066 mm (1.1050 in)	
Cam pulley	Cam lobe height	37.394 mm (1.4722 in)	37.369 mm (1.4712 in)	
	Cam pulley ID (bearing)	10.027 mm (0.3948 in)	10.075 mm (0.3967 in)	
	Cam pulley shaft OD	9.987 mm (0.3932 in)	9.920 mm (0.3906 in)	
Rocker arm	Rocker arm ID	6.000 mm (0.2362 in)	6.043 mm (0.2379 in)	
	Rocker arm shaft OD	5.990 mm (0.2358 in)	5.953 mm (0.2344 in)	
	Rocker arm shaft bearing ID	6.000 mm (0.2362 in)	6.043 mm (0.2379 in)	
Ignition coil (aluminum flywheel type)	Resistance	Primary coil 1.0 ~ 1.2 Ω Secondary coil 10.6 ~ 12.8 kΩ	-----	
	Air gap (at flywheel)	0.2 ~ 0.6 mm (0.008 ~ 0.024 in)	-----	
Ignition coil (cast-iron flywheel type)	Resistance	Primary coil 0.68 ~ 0.84 Ω Secondary coil 5.6 ~ 6.9 kΩ	-----	
	Air gap (at flywheel)	0.2 ~ 0.5 mm (0.008 ~ 0.020 in)	-----	
Flywheel brake	Brake shoe thickness	6 mm (0.24 in)	3.0 mm (0.12 in)	

**Carburetor Specifications**

The carburetor ID is cast into the carburetor as shown. Go to the engine model and find the carburetor ID.

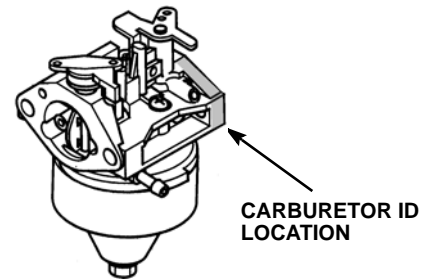

**GCV135**

Carburetor I.D. No.	Part Number	Main Jet (1/100 mm)	Float Height (mm)	Pilot Screw (turns out)
BB64A A	16100-ZM1-003	60	9.2	1-5/8
BB64A B	16100-ZM1-013	60	9.2	1-1/4
BB64A C	16100-ZM1-023	60	9.2	1-1/4
BB64A D	16100-ZM1-033	60	9.2	1-1/4
BB64B A	16100-ZM1-801	60	9.2	1-5/8
BB64B B	16100-ZM1-802	60	9.2	1-1/4
BB64B C	16100-ZM1-803	60	9.2	1-1/4
BB64F A	16100-ZM1-822	62	9.2	1-1/4
BB64F B	16100-ZM1-823	62	9.2	1-1/4
BB64G B	16100-Z0M-782	62	9.2	1-1/8

**GCV160**

Carburetor I.D. No.	Part Number	Main Jet (1/100 mm)	Float Height (mm)	Pilot Screw (turns out)
BB62A D	16100-ZM0-023	65	9.2	1
BB62B C	16100-ZM0-802	65	9.2	1
BB62B D	16100-ZM0-803	65	9.2	1
BB62B E	16100-ZM0-804	65	9.2	1
BB62W A	16100-Z0L-003	65	9.2	1
BB62W B	16100-Z0L-013	65	7.2	1
BB62F A	16100-Z0L-781	65	9.2	1-3/8
BB62F B	16100-Z0L-782	65	9.2	1-3/8
BB62Y A	16100-Z1L-003	65	9.2	1-3/8
BB62Y B	16100-Z1L-013	65	7.2	1-3/8
BB62G B	16100-Z0L-802	65	9.2	Not Applicable
BB62H B	16100-Z0L-812	65	9.2	Not Applicable
BB62Z A	16100-Z0L-851	65	9.2	Not Applicable
BB62Z B	16100-Z0L-852	65	7.2	Not Applicable
BB65A A	16100-Z0L-861	65	9.2	Not Applicable
BB65A B	16100-Z0L-862	65	7.2	Not Applicable
BB65E A	16100-Z0L-871	70	9.2	Not Applicable
BB65E B	16100-Z0L-872	70	7.2	Not Applicable
BB75E A	16100-Z0L-874	68	7.2	Not Applicable
BB75E B	16100-Z0L-875	68	7.2	Not Applicable

## SERVICE INFORMATION

---

### GCV190

Carburetor I.D. No.	Part Number	Main Jet (1/100 mm)	Float Height (mm)	Pilot Screw (turns out)
BB62J A	16100-Z0Y-003	70	9.2	1-5/8
BB62J B	16100-Z0Y-013	70	9.2	1-5/8
BB62K B	16100-Z0Y-802	70	9.2	1-5/8
BB65B A	16100-Z0Y-811	70	9.2	1-5/8
BB65B B	16100-Z0Y-812	70	7.2	1-5/8
BB65C A	16100-Z0Y-821	70	9.2	1-5/8
BB65J A	16100-Z0Y-841	65	9.2	2-1/2
BB65M A	16100-Z0Y-851	70	7.2	NA
BB75A A	16100-Z0Y-871	68	7.2	1-5/8
BB75F A	16100-Z0Y-M41	68	7.2	2

### GSV190

Carburetor I.D. No.	Part Number	Main Jet (1/100 mm)	Float Height (mm)	Pilot Screw (turns out)
BB62M A	16100-Z2D-003	68	9.2	1-1/8
BB62M B	16100-Z2D-013	68	9.2	1-1/8
BB62N A	16100-Z2D-801	68	9.2	1-1/8
BB62N B	16100-Z2D-802	68	9.2	1-1/8
BB65G A	16100-Z2D-811	68	9.2	1-1/8
BB65G B	16100-Z2D-812	68	7.2	1-1/8
BB65D A	16100-Z2D-821	68	9.2	1-1/8

## 5. TORQUE VALUES

SPECIAL FASTENERS	THREAD DIAMETER x PITCH mm (in)	TORQUE		
		N•m	kg-m	ft-lb
Oil pan bolt	6 x 1.0 (CT)	12	1.2	8.7
Connecting rod bolt	7 x 1.0 Special	12	1.2	8.7
Valve adjusting lock nut	5 x 0.5 Special	8	0.8	5.8
Cylinder head cover bolt	6 x 1.0	12	1.2	8.7
Governor arm nut	6 x 1.0	10	1.0	7.2
Breather cover bolt	6 x 1.0	12	1.2	8.7
Air cleaner case bolt	6 x 1.0 (CT)	10	1.0	7.2
	6 x 1.0			
Muffler bolt	6 x 1.0	12	1.2	9
Recoil starter nut	6 x 1.0	8.5	0.85	6.1
Fan cover stud bolt	6 x 1.0	12	1.2	8.7
Fuel valve bracket screw	5 x 0.8	3	0.3	2.2
Governor holder bolt	6 x 1.0	12	1.2	8.7
Engine stop switch screw	4 x 0.7	1.8	0.18	1.3
Spark plug	14 x 1.25	20	2.0	14
Starter motor mounting bolts	M6 x 1.0	11	1.1	8.1
Flywheel nut (aluminum flywheel) (cast-iron flywheel)	14 x 1.5	75	7.5	55
	14 x 1.5	75 ~85	7.5 ~ 8.5	55 ~ 63

Use standard torque values for fasteners that are not listed above.  
(CT) Indicates a self-tapping bolt.

## STANDARD TORQUE VALUES

STANDARD FASTENERS	THREAD DIAMETER	TORQUE		
		N•m	kg-m	ft-lb
Screw	5 mm	3.9	0.4	2.9
	6 mm	8.8	0.9	6.5
Bolt and nut	5 mm	4.9	0.5	3.6
	6 mm	9.8	1.0	7.2
	8 mm	21	2.1	15
	10 mm	34	3.5	25
	12 mm	54	5.5	40
Flange bolt and nut	6 mm	12	1.2	8.7
	8 mm	26	2.7	20
	10 mm	39	4.0	29

## SERVICE INFORMATION

### 6. TOOLS

#### a. COMMERCIALLY AVAILABLE

There are two convenient ways to order: online or by toll-free phone.

- To order online, go to the iN: SERVICE>Tools>Tool and Equipment Program>Online Catalog, and then search by model number.
- To order by phone, call 1-888-424-6857.  
Customer service representatives are available from 7:30 AM until 7:00 PM CT, Monday through Friday.

ITEM	TOOL NAME	TOOL NUMBER	APPLICATION	
1A	Dial indicator and magnetic base	FPL-72-520-300	Crankshaft runout check and crankshaft axial clearance check	
1B	Dial indicator magnetic base	FFL-72-585-010		
2	Compression gauge	SUN-EEP-V303A		Compression test
3	Strap wrench	STV-S-17		Flywheel removal
4	Flywheel puller	OTC-1035		Flywheel removal
5	Digital multimeter	FLU-88		Electrical component testing
6	Combustion chamber cleaning brush and drill extension	Procured locally		Clean combustion chamber
7A	Valve seat cutter, 31°	NWY CU 115		Valve seat reconditioning
7B	Valve seat cutter, 45°	NWY CU 122		
7C	Valve seat cutter, 60°	NWY CU 111		
7D	Solid pilot bar, 5.50 mm	NWY PM 10055SH		
7E	Solid pilot bar, 5.52 mm	NWY PM 100552S		
7F	T-wrench, #505	NWY TW 505		
7G	T-wrench adaptor, #503-1	NWY TW 503-1		
7H	Accessory package #246	NWY KACC 246		
7I	T-wrench extension, 6 in	NWY TW 503-6H		
8	Leak down tester	KLIAT1006M	Cylinder leak down	
9	Vacuum pump	LSL07000	Auto Throttle® diaphragm test	

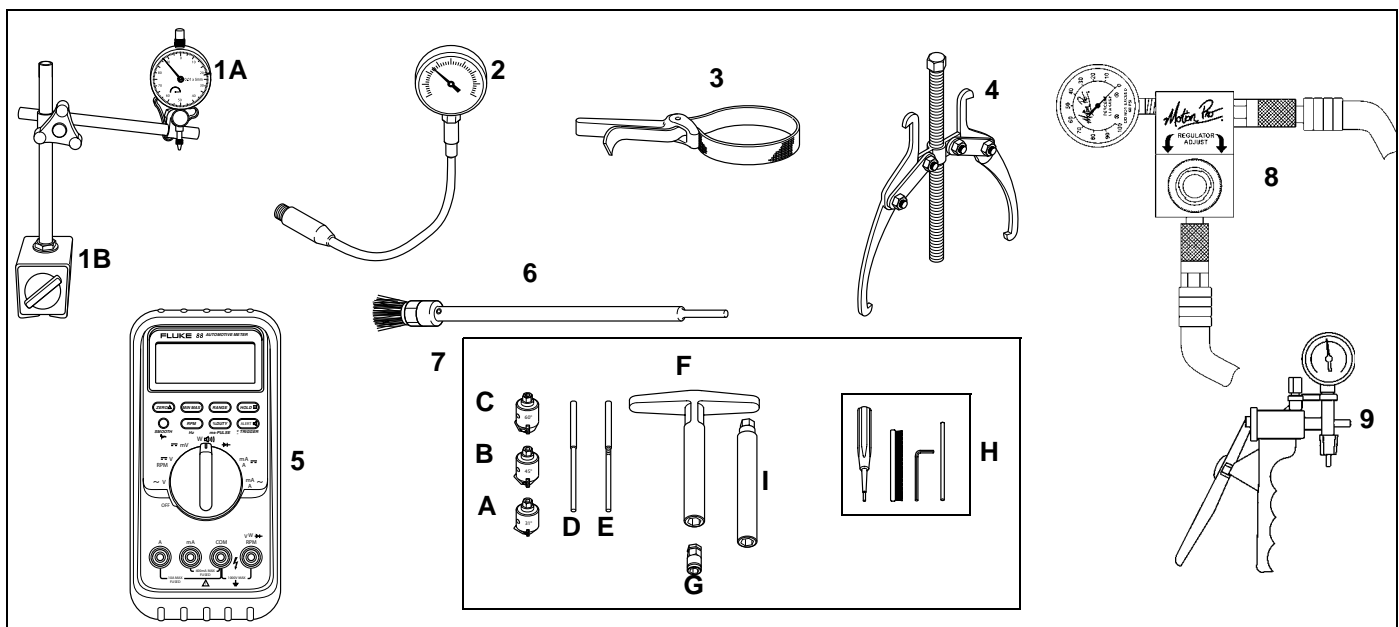

**b. SPECIAL**

These tools are distinguished by the  special tool box icon and normally start with a "07" tool number. They are available through the American Honda Parts Department and ordered by using normal American Honda Parts ordering procedures.

ITEM	TOOL NAME	TOOL NUMBER	APPLICATION
1	Carburetor float level gauge	07401-0010000	Carburetor float level inspection
2	Valve adjustment wrench, 3 mm	07908-KE90200	Valve clearance adjustment
3	Jet Cleaner Set	07JPZ-001010B	Cleaning carburetor jets

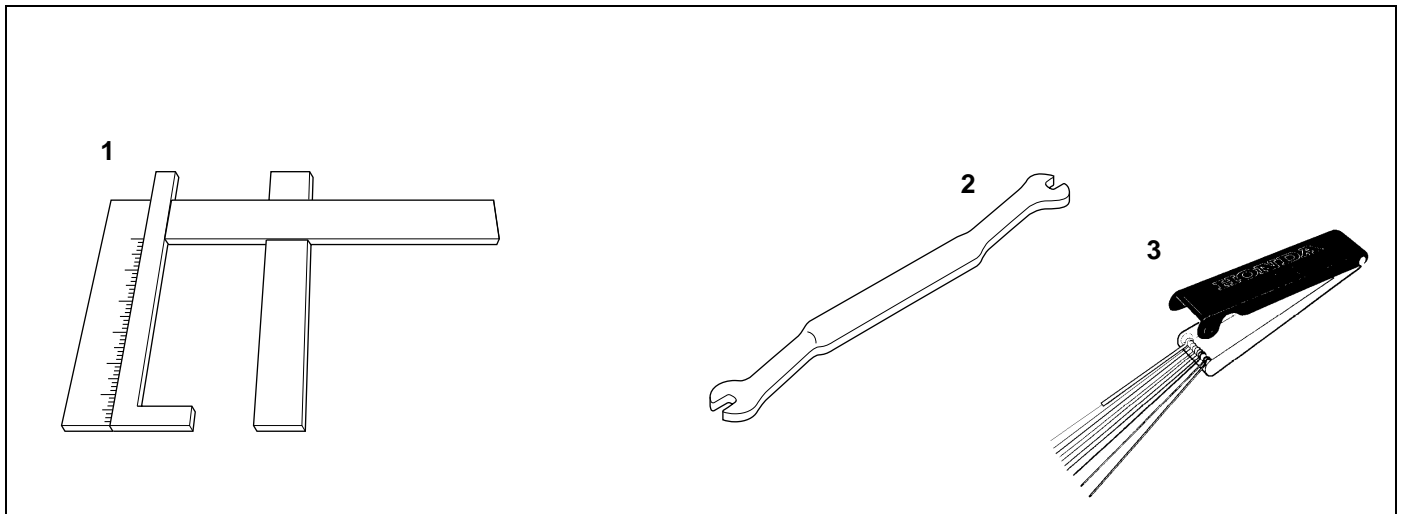



## 7. TROUBLESHOOTING

### a. GENERAL SYMPTOMS AND POSSIBLE CAUSES

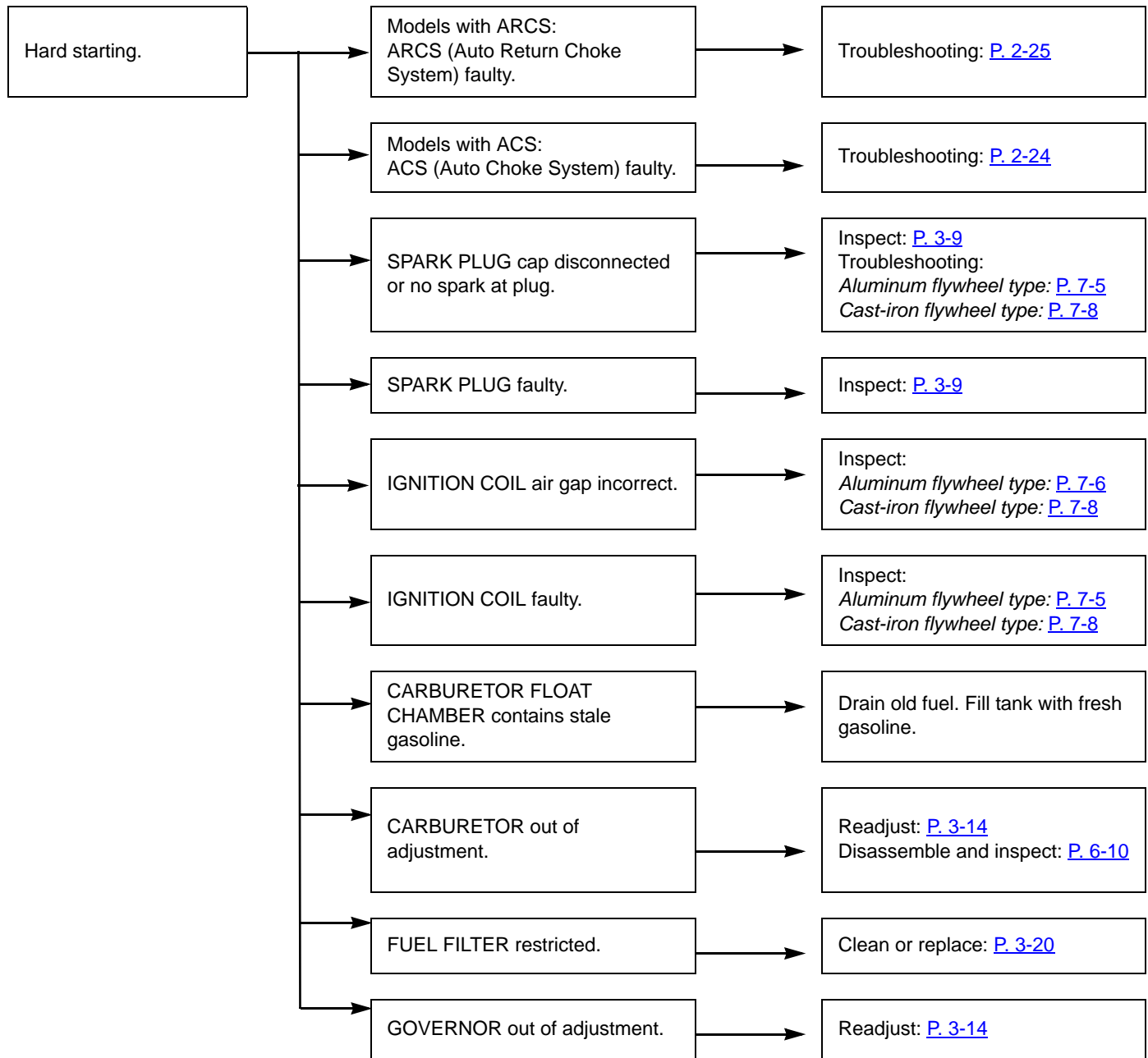

## SERVICE INFORMATION

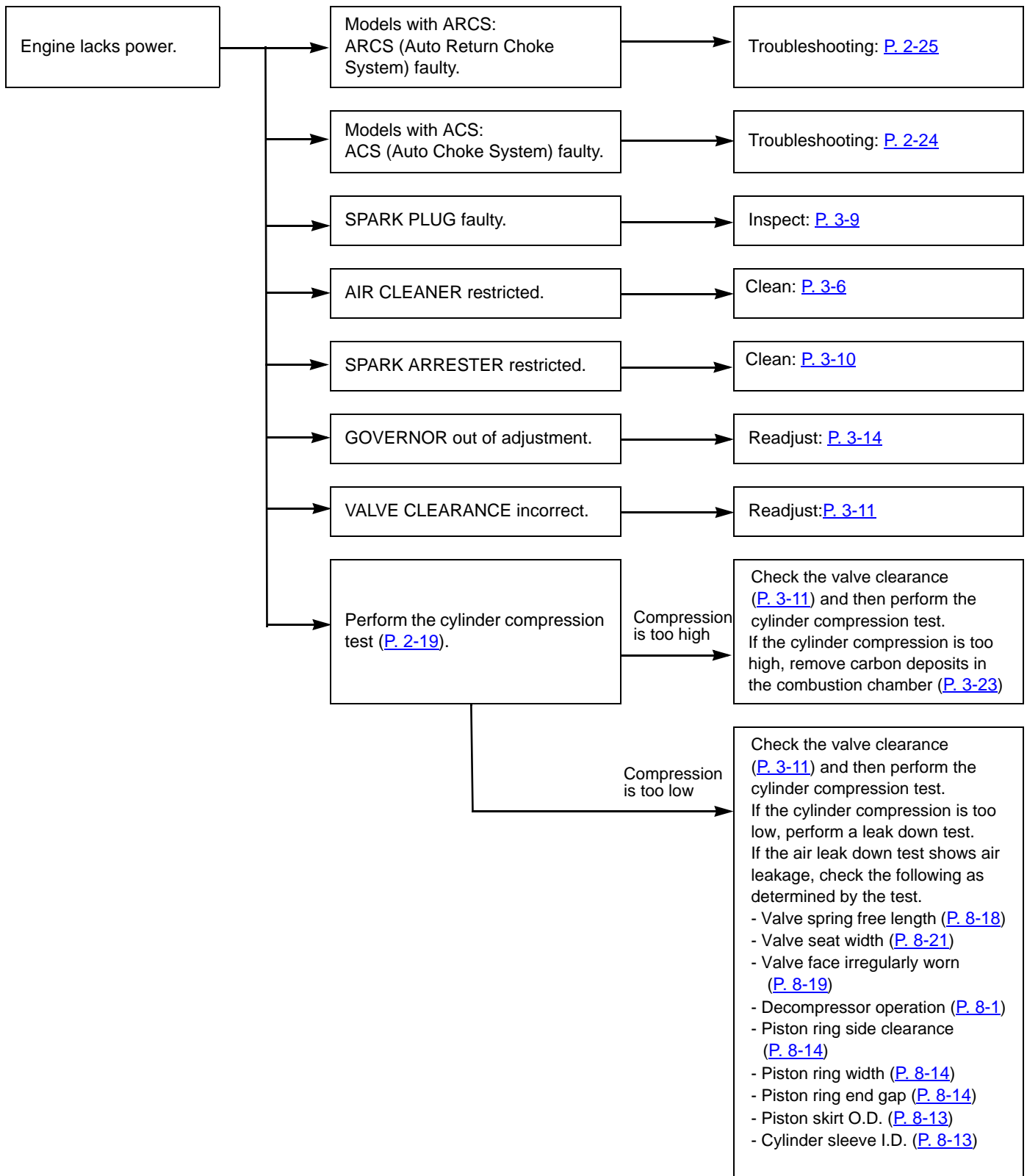

## SERVICE INFORMATION

---

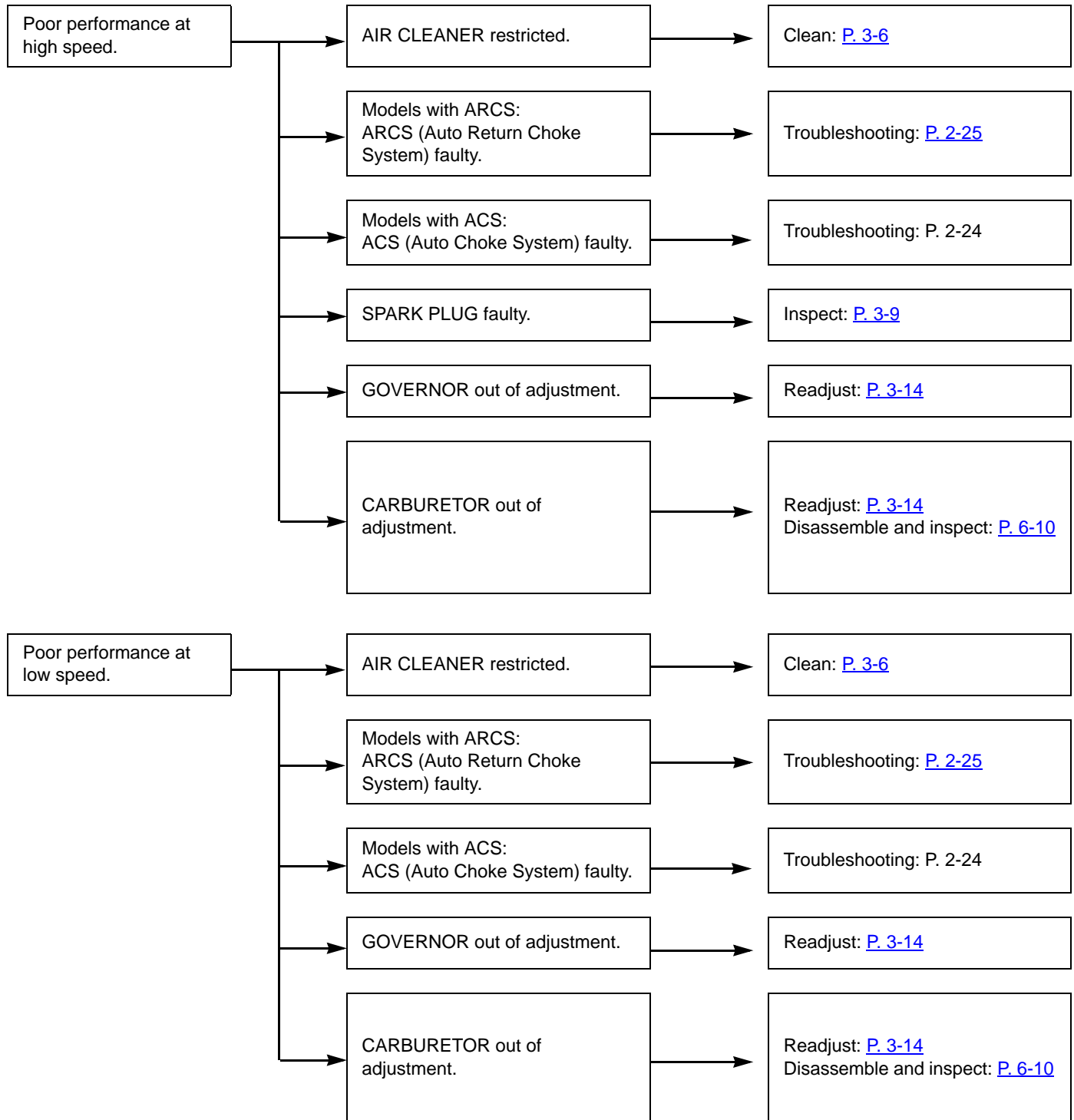

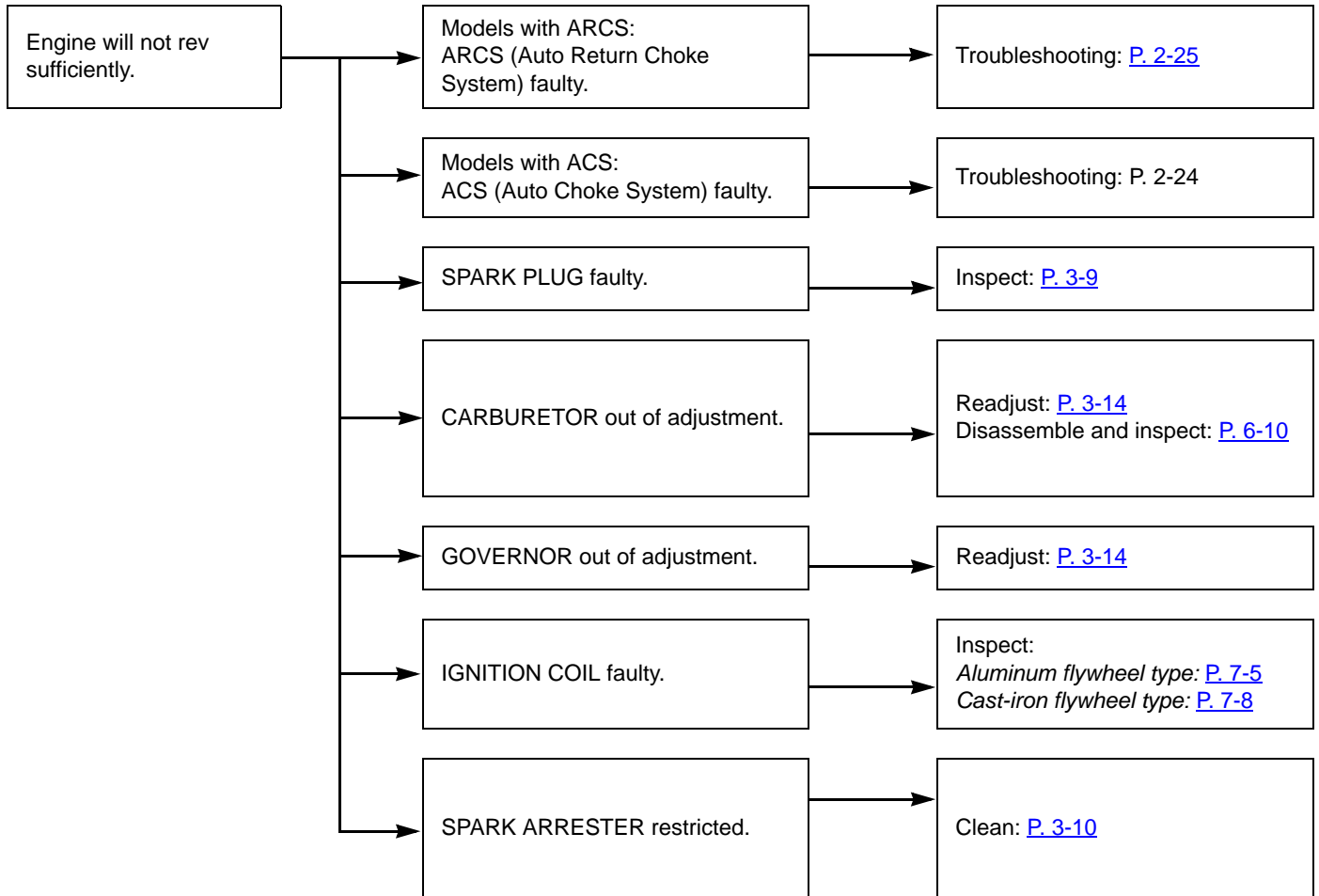

# SERVICE INFORMATION

## b. HARD STARTING

Move the fuel valve lever to the ON position.

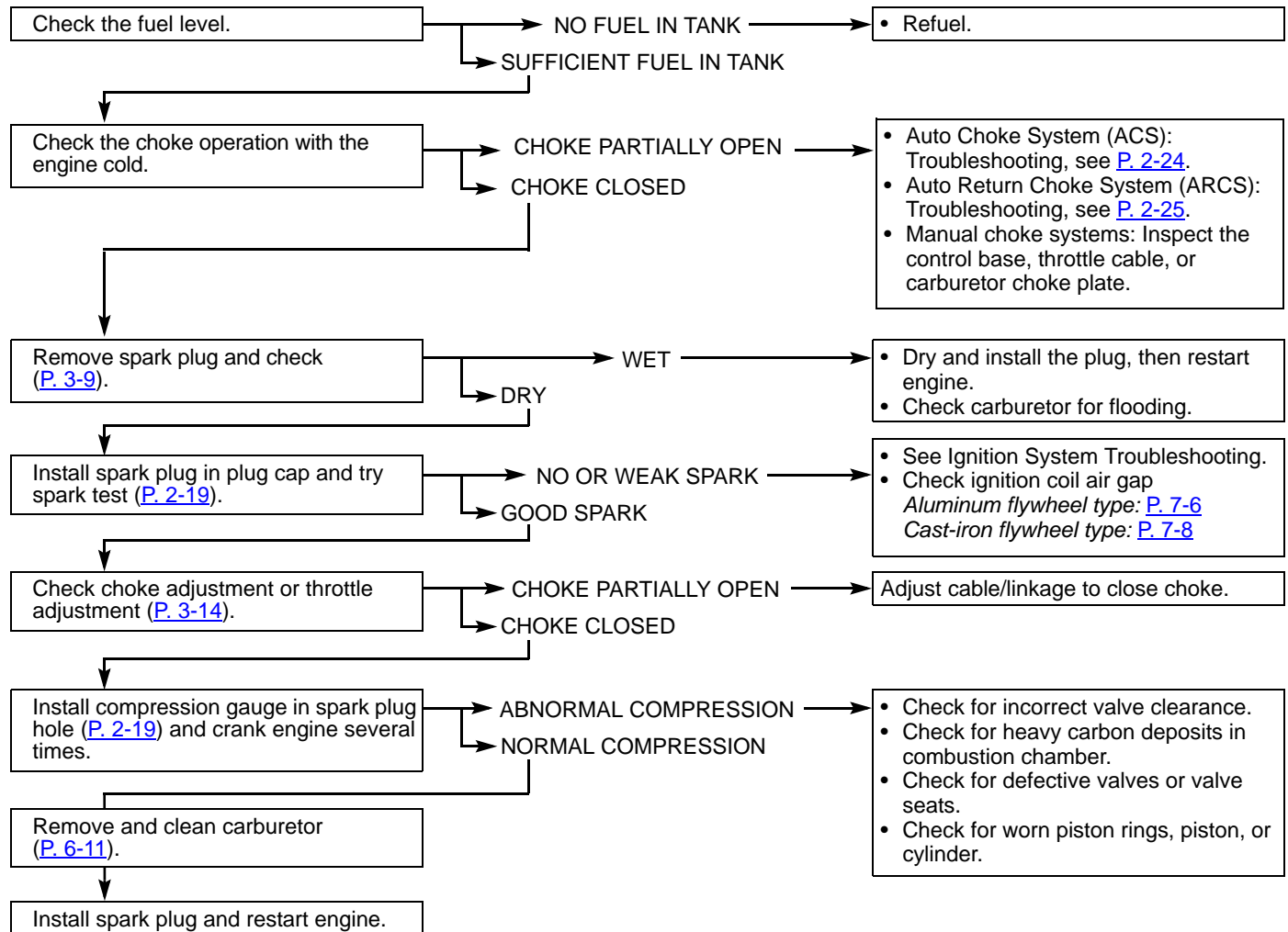

c. IGNITION SYSTEM

• CAST-IRON FLYWHEEL TYPES

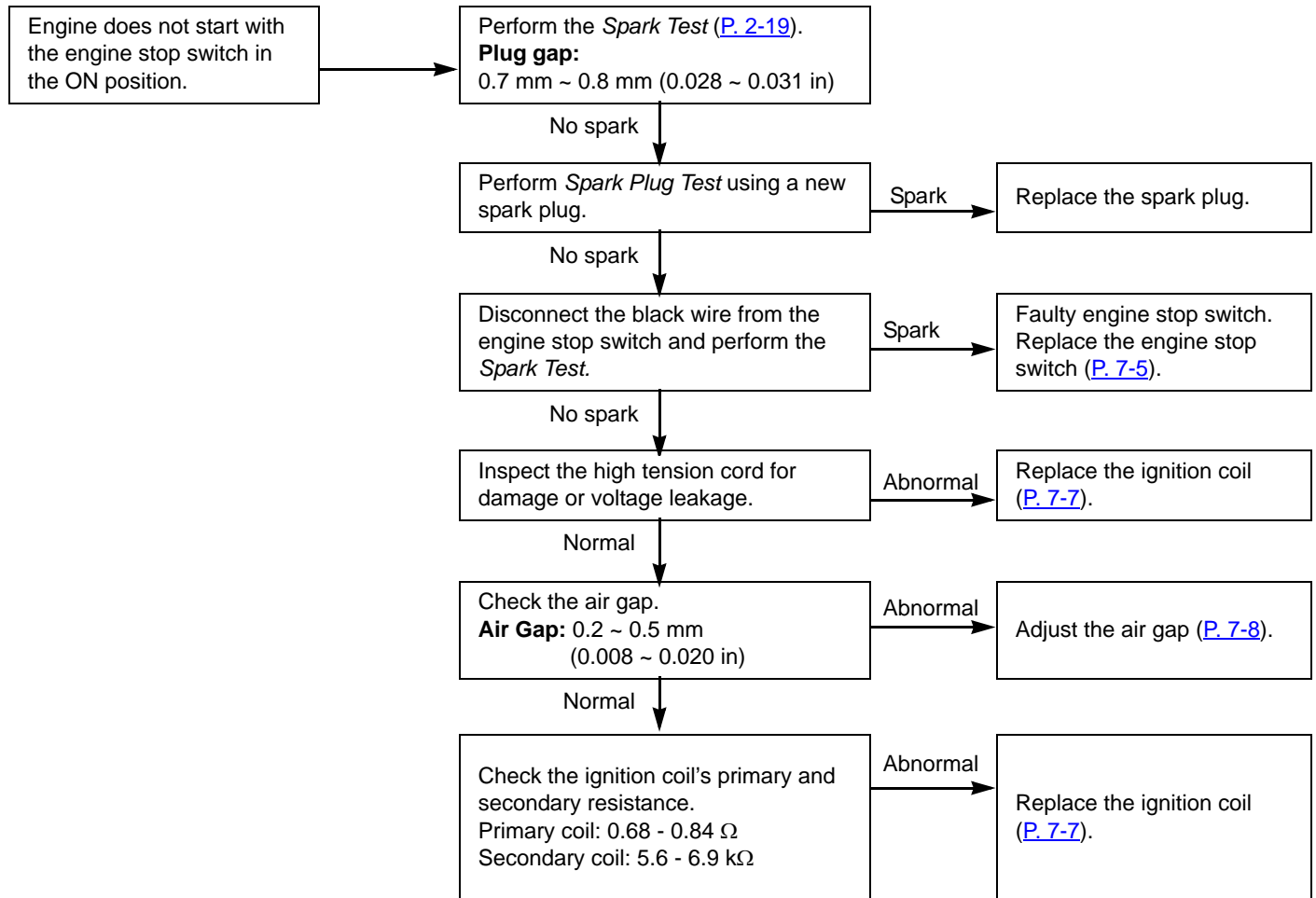

## SERVICE INFORMATION

### • ALUMINUM FLYWHEEL TYPES

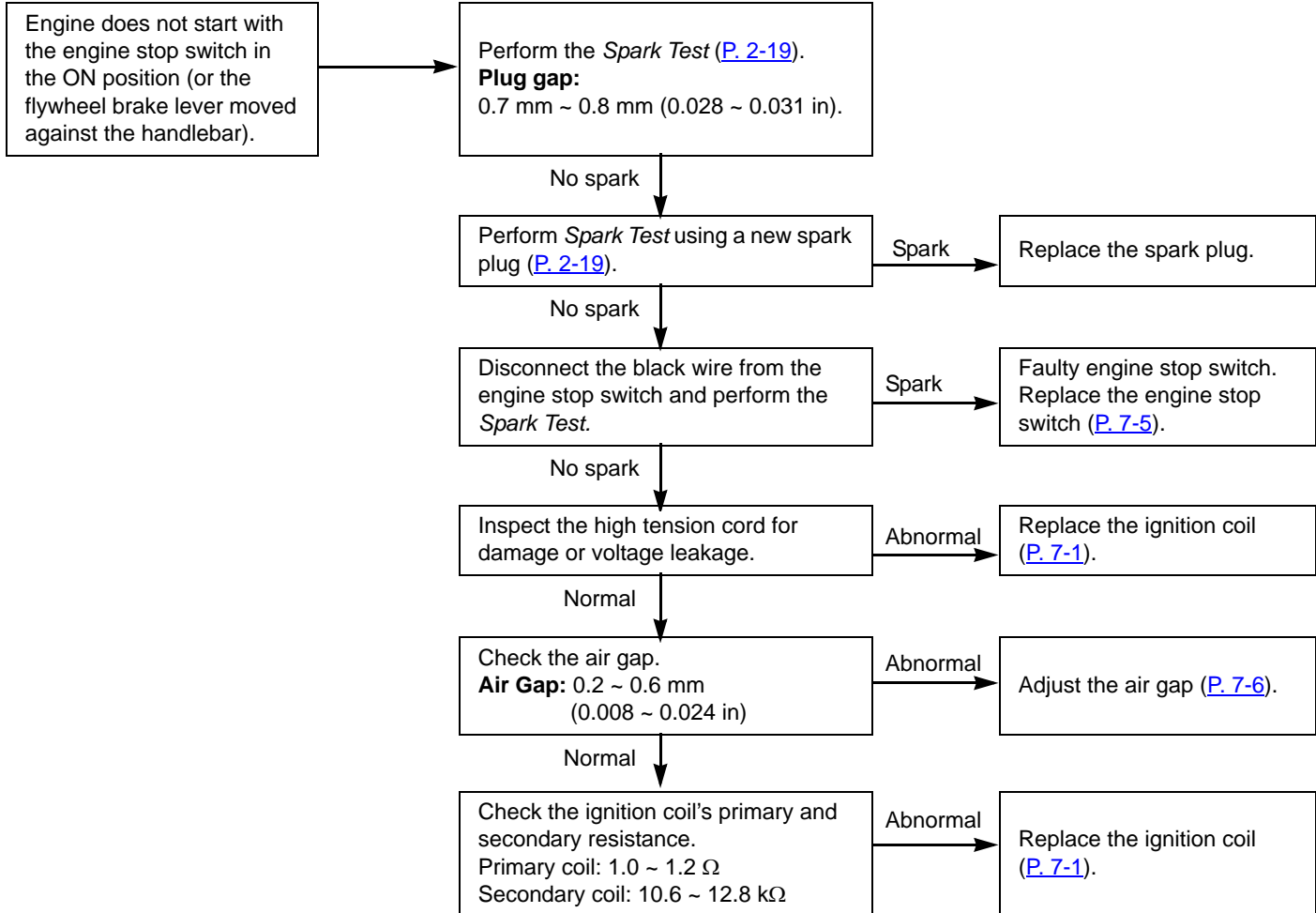

**d. ENGINE LACKS POWER**

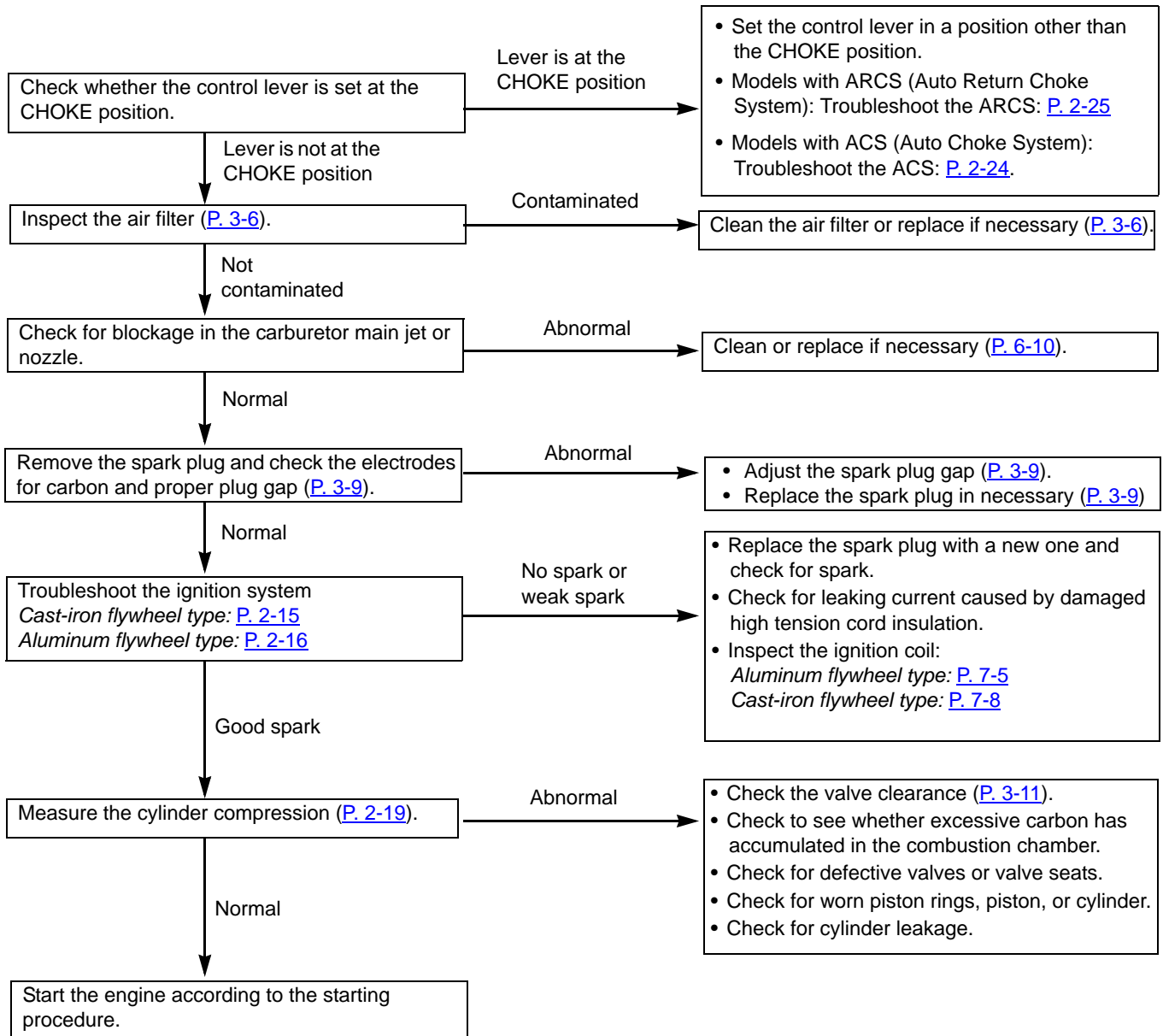



## SERVICE INFORMATION

### e. ENGINE SPEED DOES NOT INCREASE

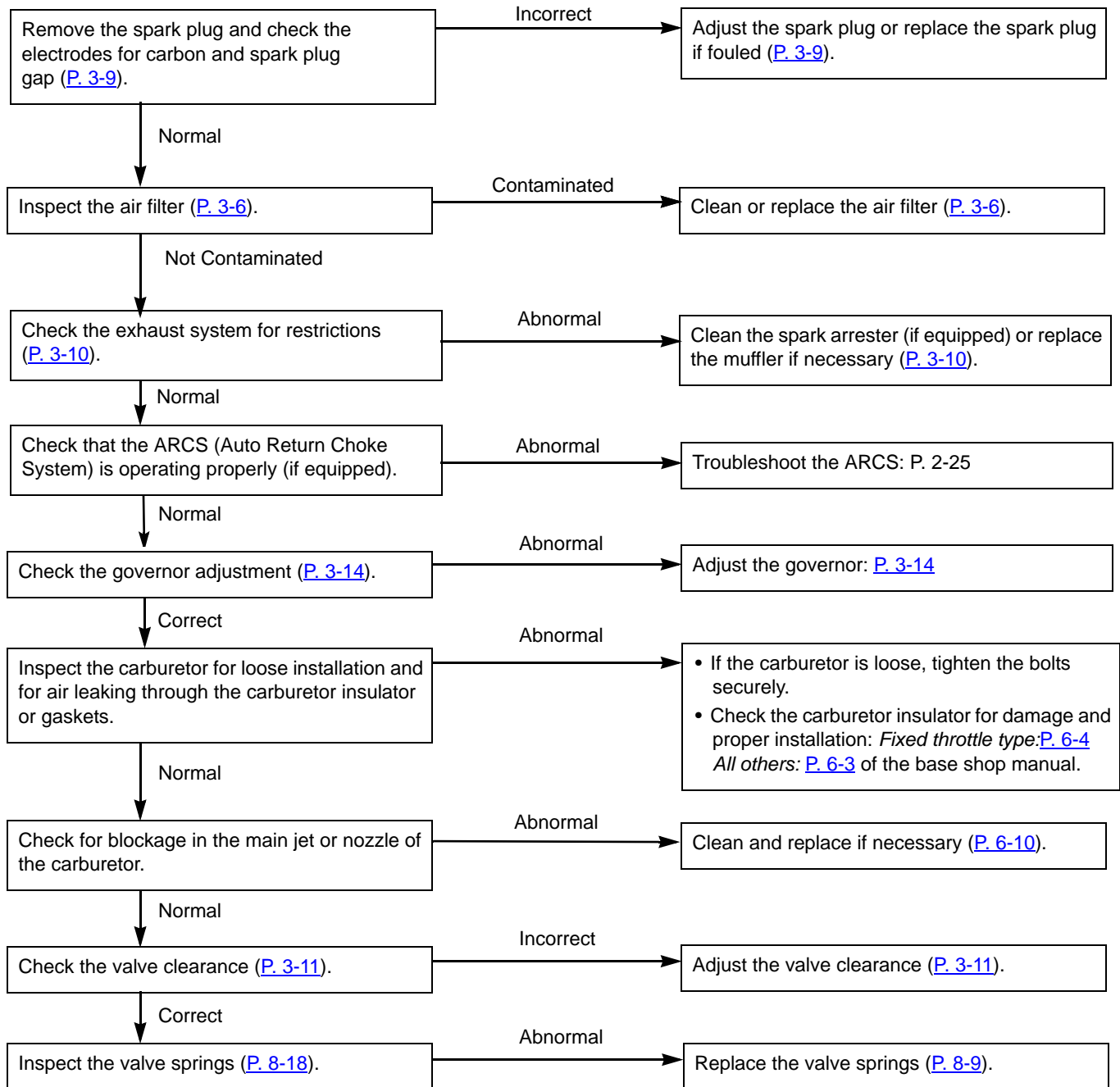

**f. COMPRESSION TEST**

1. Remove the spark plug and install a compression gauge in the spark plug hole.
2. Move the throttle lever to the FAST position.
3. On flywheel brake types, push the flywheel brake lever forward against the handlebar.
4. Crank the engine several times with the recoil starter and measure compression.

Compression*	490 kPa (71 psi) at 600 rpm
--------------	--------------------------------

\*Decompression mechanism engaged.

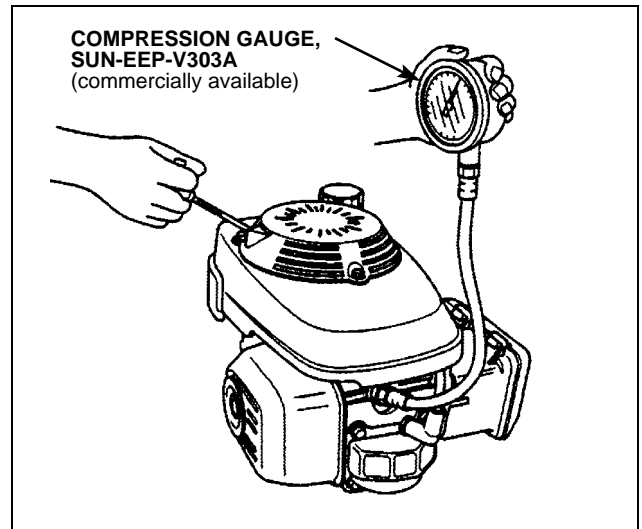

**g. SPARK PLUG TEST**

1. Remove the spark plug, attach it to the spark plug cap, and ground the side electrode against the cylinder head cover.

**⚠ WARNING**

Gasoline is highly flammable and explosive. If ignited, gasoline can burn you severely.

Before testing the spark plug:

- Be sure there is no spilled fuel near the engine.
- Place the spark plug away from the spark plug hole.

2. Verify that the engine switch is in the ON position, or on flywheel brake types, push the flywheel brake lever forward against the handlebar.
3. Pull the recoil starter and check to see if sparks jump across the electrodes.

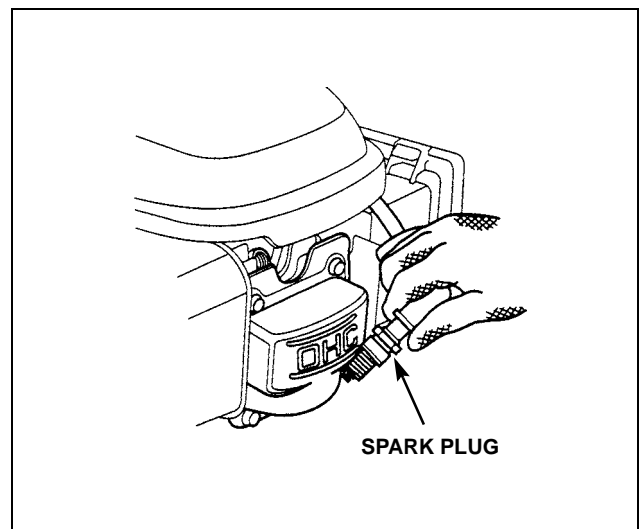

# SERVICE INFORMATION

## h. FLYWHEEL BRAKE

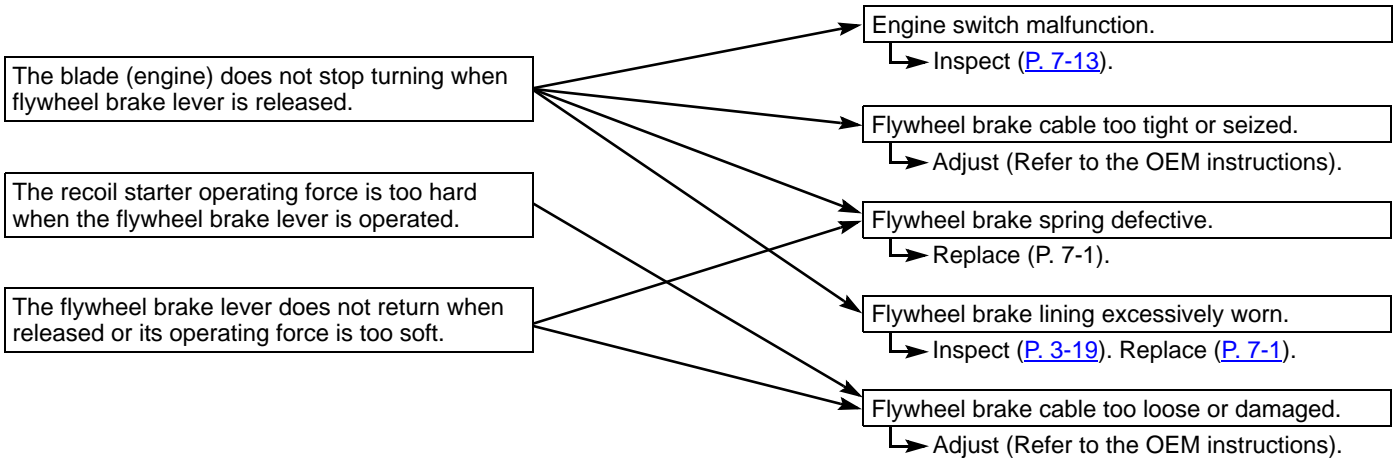

## i. ROTO-STOP®

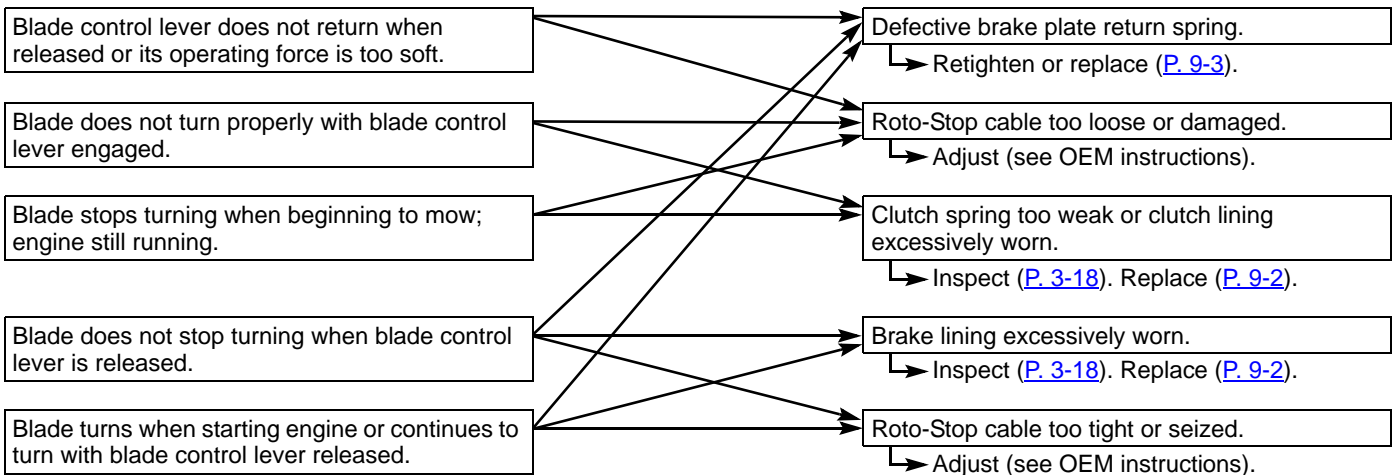

**j. STARTER MOTOR TROUBLESHOOTING PROCEDURE**

**Starter Motor Does Not Rotate When The Key Is Turned To The Start Position.**

Possible Cause	Correction	Refer to
Battery is discharged.	Disconnect the battery and measure the voltage at the battery connector. If less than 12.0 VDC, recharge the battery and retest.	*
Fuse is blown.	Check the 40 amp starter fuse and replace if blown.	*
Wire connector is loose.	Check wire connections at the starter motor and battery.	<a href="#">P. 2-36</a>
Starter pinion is stuck engaged in the flywheel teeth.	Replace damaged flywheel. Confirm that the starter pinion assembly moves freely on the shaft. (Starter motor replacement should not be required.)	<a href="#">P. 7-3</a> *

**Starter Motor Turns But The Pinion Does Not Raise And Engage The Flywheel.**

Possible Cause	Correction	Refer to
Battery is partially discharged.	Check cranking voltage at the starter motor.	<a href="#">P. 2-22</a>
Starter pinion is stuck on the starter shaft.	Remove the starter. Inspect the shaft and the pinion damper assembly. Verify that the pinion assembly climbs up the shaft.	<a href="#">P. 7-9</a> <a href="#">P. 2-23</a>

**Pinion Damper Slips. Pinion Engages The Flywheel But Rotates The Engine Slowly Or Not At All.**

Possible Cause	Correction	Refer to
Battery is partially discharged.	Check cranking voltage at the starter motor.	<a href="#">P. 2-22</a>
Engine is hard to start or is seized.	Verify that the engine will easily start using the starter grip.	*
Starter pinion damper is contaminated with grease or oil.	Clean and inspect the pinion damper assembly.	<a href="#">P. 2-23</a>

\* Refer to the equipment manufacturer's service procedure.

## SERVICE INFORMATION

---

### CHECK CRANKING VOLTAGE AT THE STARTER MOTOR

1. Turn the fuel valve OFF and disconnect the spark plug cap.
2. Slide the covers down from the starter motor connectors.
3. Set the voltmeter to measure 5 ~ 20 VDC and carefully connect the alligator clips to the connectors at the starter motor.

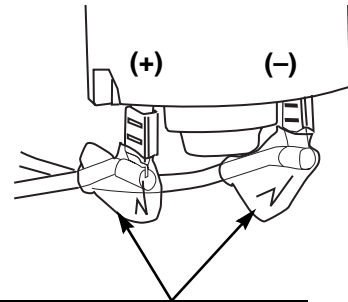

Slide the starter motor connector covers down to attach the voltmeter alligator clips.

4. Connect the positive alligator clip to the terminal closest to the oil filler, taking care not to ground (short) the lead. Connect the negative alligator clip to the negative lead.
5. Check the cranking voltage at the starter by turning the key to the start position for 4 seconds and then releasing for 10 seconds.

Perform this test 3 times and verify that the cranking voltage does not drop below 8.5 VDC.

6. If the cranking voltage drops below 8.5 VDC, recharge the battery according to the equipment manufacturer's instructions.

The battery charger must be capable of providing a voltage greater than 13 VDC. Verify charger performance according to the manufacturer's instructions.

7. After charging the battery, check the cranking voltage again. If the proper cranking voltage still cannot be obtained, replace the battery.

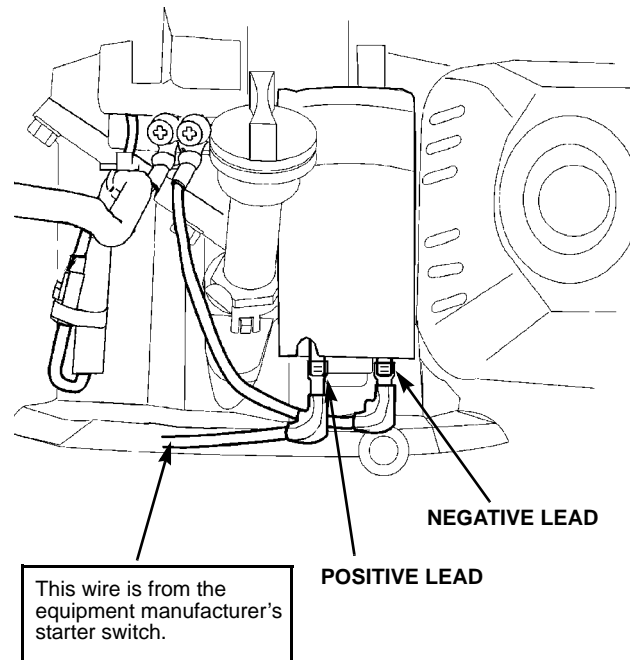

This wire is from the equipment manufacturer's starter switch.

**CLEANING AND INSPECTING THE PINION DAMPER ASSEMBLY**

1. Remove the starter motor (See [P. 7-10](#)).
2. Separate the pinion rubber damper from the drive plate.

Using your thumbs, push the pinion vertically on the shaft, in the direction shown. Do not rotate the pinion assembly.

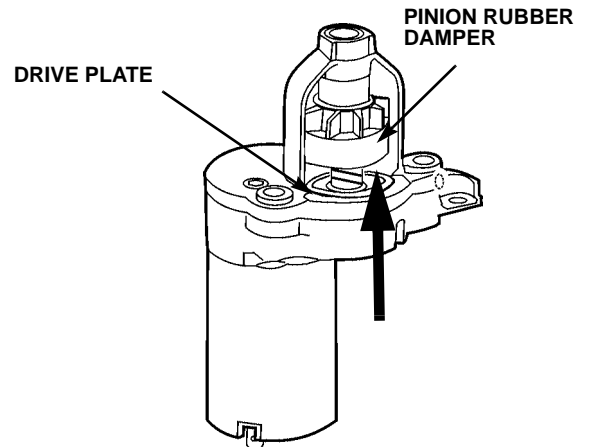

3. Thoroughly clean between the drive plate and damper using a rubber-compatible contact cleaner or brake cleaner. Use a cotton swab or other utensil to remove any residue from the damper rubber and drive plate.

Do not use compressed air to remove residue as it may force cleaner or debris into the starter gearbox.

4. After cleaning, verify no oil or grease residue is present and the damper and drive plate are dry.

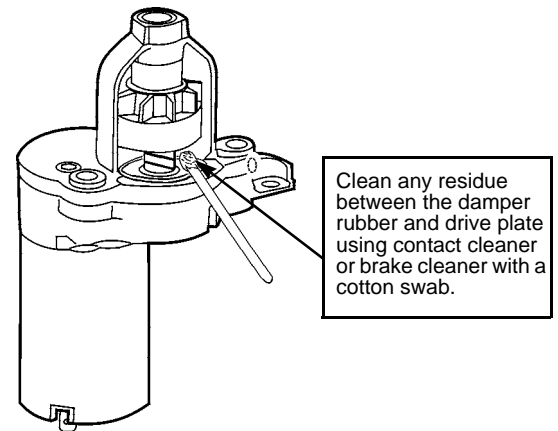

5. Inspect the rubber damper seal for damage. Replace the starter if the rubber damper is damaged or will not seat properly around the drive plate.

6. Firmly push the pinion rubber damper down over the drive plate.

Make sure the damper rubber seal lip is properly positioned and seated around the drive plate.

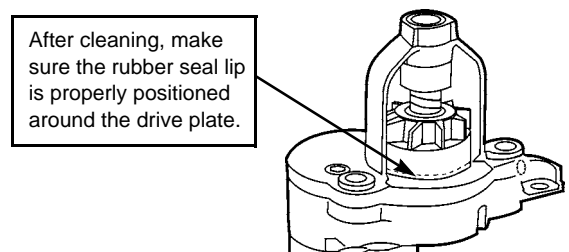

7. Rotate the pinion clockwise as shown to verify that the pinion and drive plate assembly climb up the shaft.
8. Reinstall the starter motor and test for proper operation.

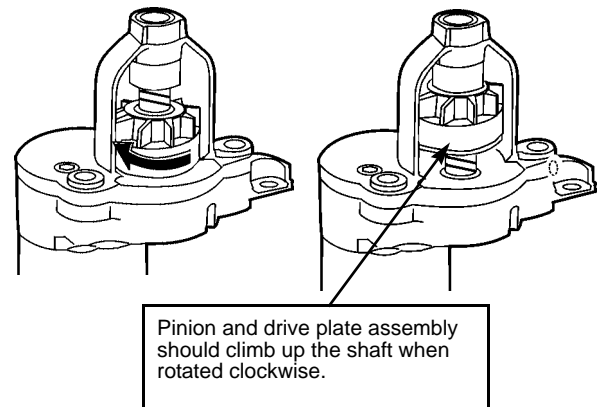

# SERVICE INFORMATION

## k. AUTO-CHOKE SYSTEM (ACS)

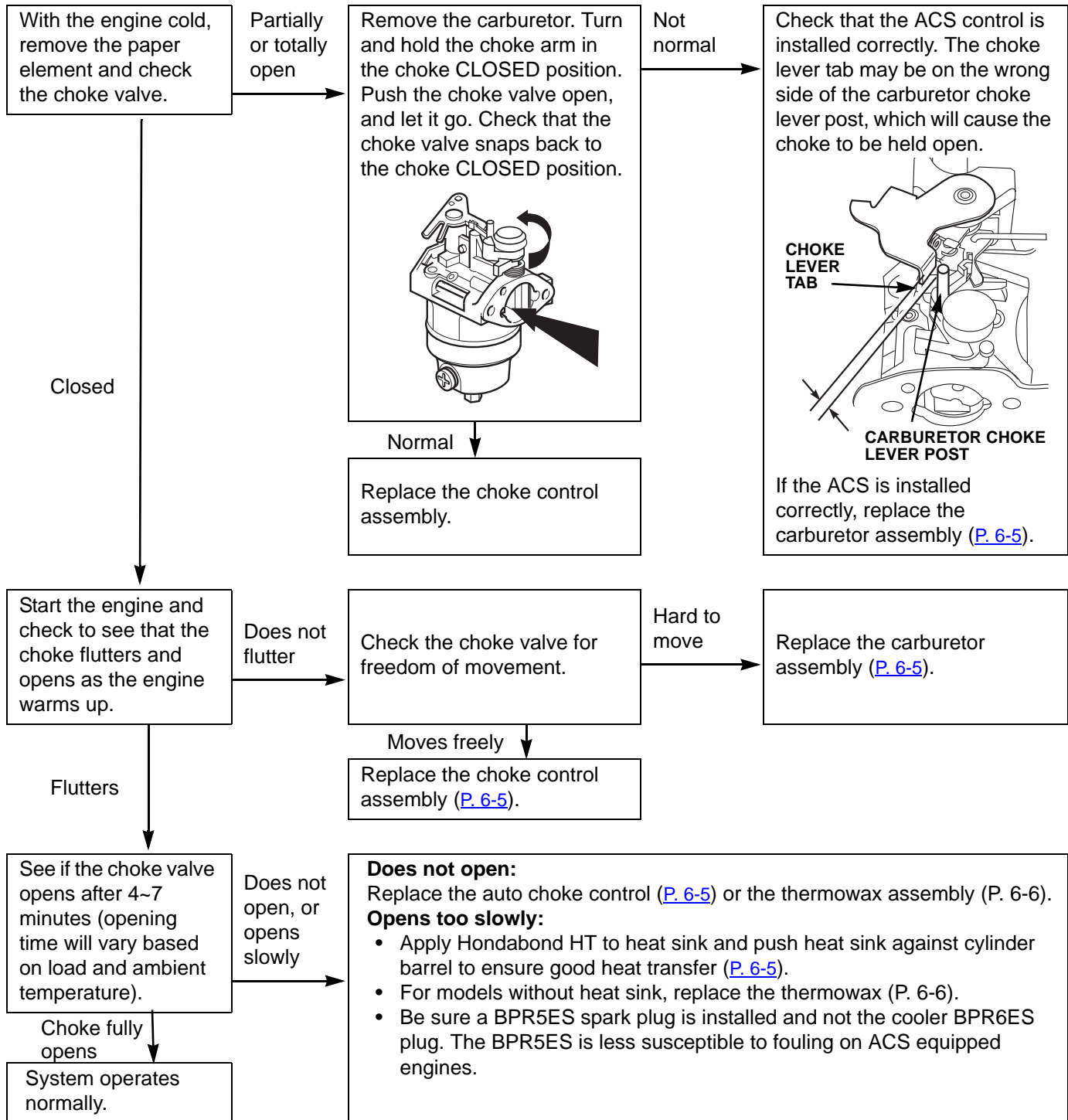

**I. ARCS (AUTOMATIC RETURN CHOKE SYSTEM)**

After setting the choke lever to the choke ON position and operating the blade control lever: ARCS lever does not return to the OFF position.

1. Set the ARCS choke lever in the  $\mathcal{N}$  (choke closed) position.
2. Without trying to start the engine, engage the blade control lever (run position) and observe the choke lever through its entire range of motion.
  - If the ARCS choke opens smoothly and completely without any hesitation, the ARCS is operating normally. No further action is required.
  - If the ARCS choke lever does not open completely and stops at any point through its operation range and stays there, proceed with the procedure below.

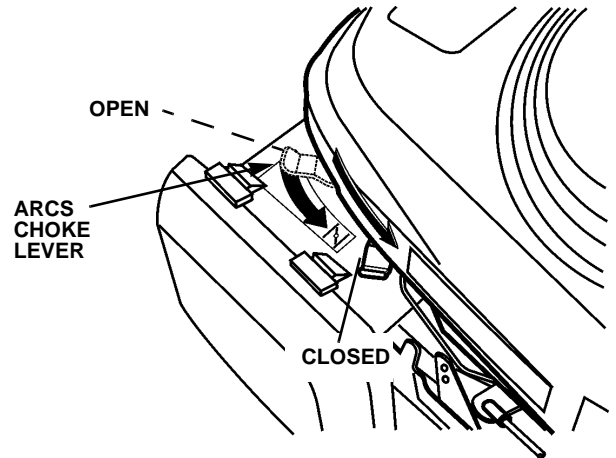

**PROCEDURE**

1. Turn the fuel valve to the OFF position.
2. Remove the spark plug cap from the spark plug.
3. Remove the recoil starter and the fan cover/fuel tank assembly.

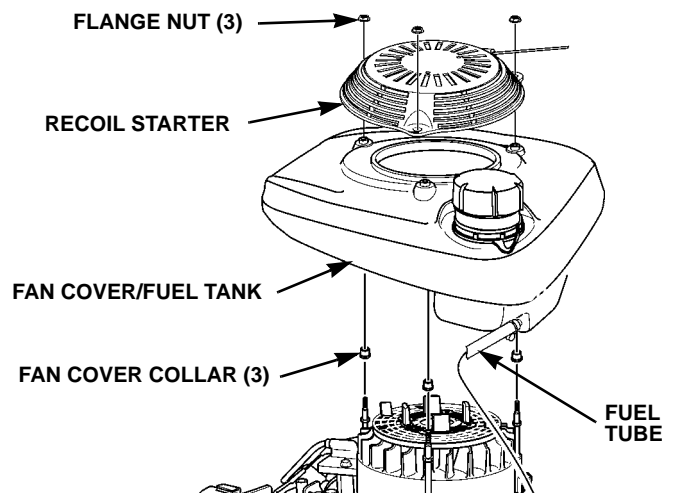
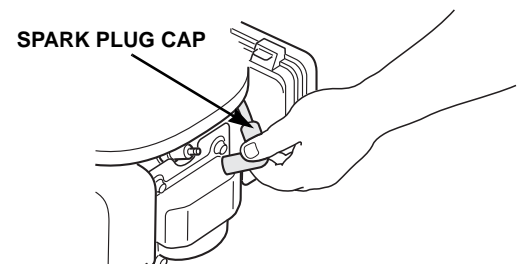
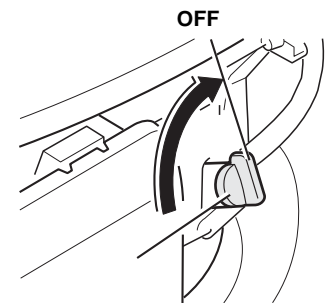



## SERVICE INFORMATION

4. If the fuel tank contains gasoline, remove the gas cap and carefully tilt the fan cover and empty the gasoline into an approved container.
5. Set the fan cover/fuel tank aside. It is not necessary to detach the fuel tube.

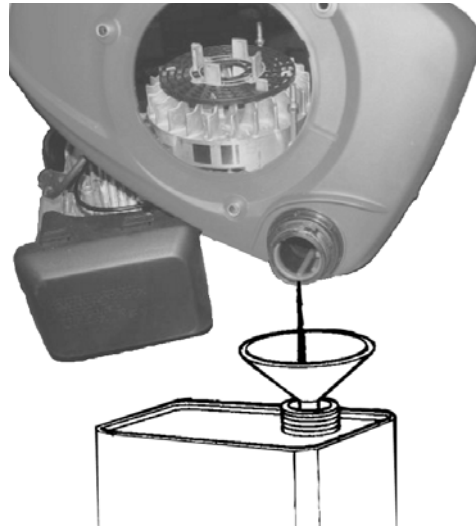

6. Move the ARCS choke lever to the choke position.
7. Engage the blade control lever (located at the handlebar) and confirm that the stop lever is completely disengaged (no contact) with the choke lever body.

- If necessary, adjust the cable per the lawn mower manufacturer's instructions and confirm the adjustment allows the ARCS to operate properly.
- If the cable has no adjustment, the stop rod can be bent to eliminate contact.

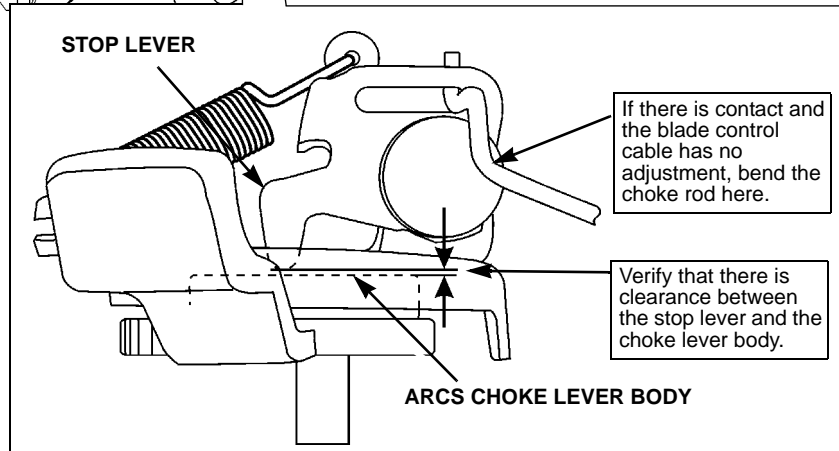
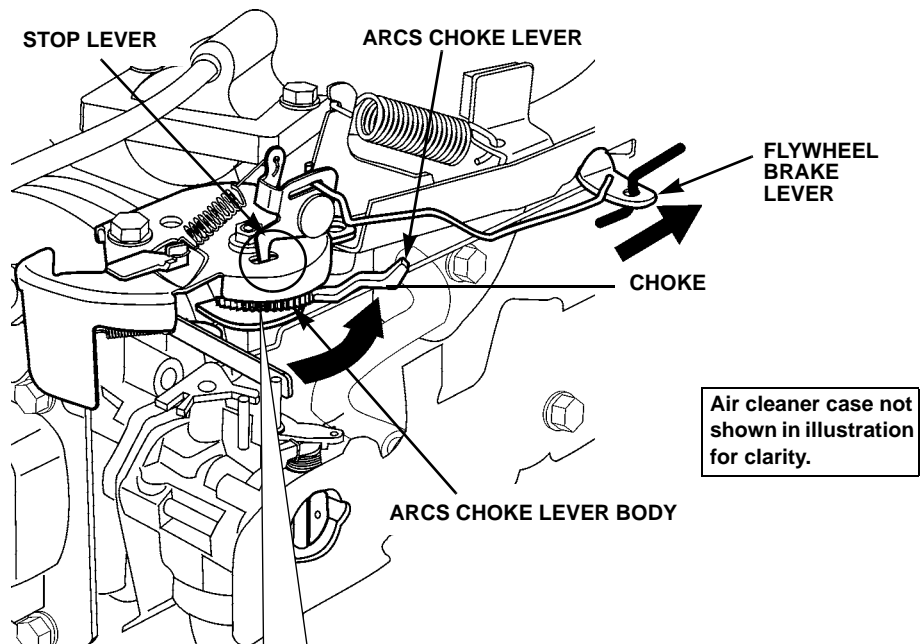

## SERVICE INFORMATION

8. As you move the ARCS choke lever to the CHOKE position, verify that:
- The ARCS choke lever does not bind on the air cleaner case.

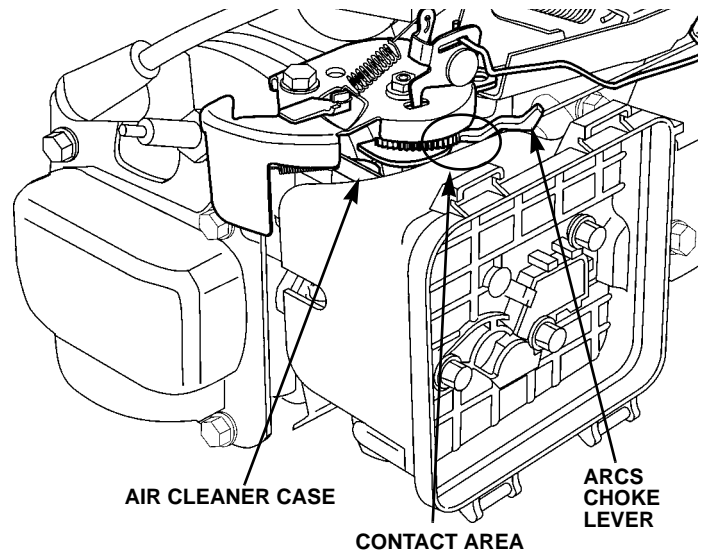

- There is no contact between the choke link and the cylinder barrel cooling fin.

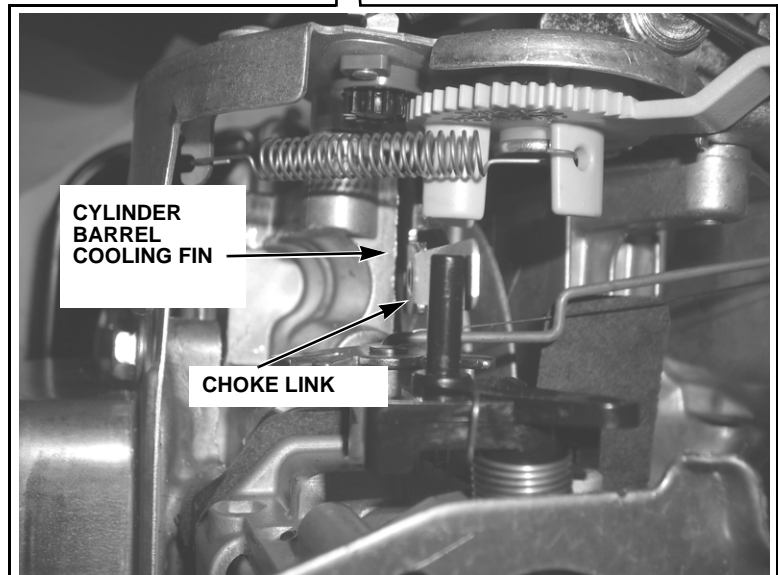
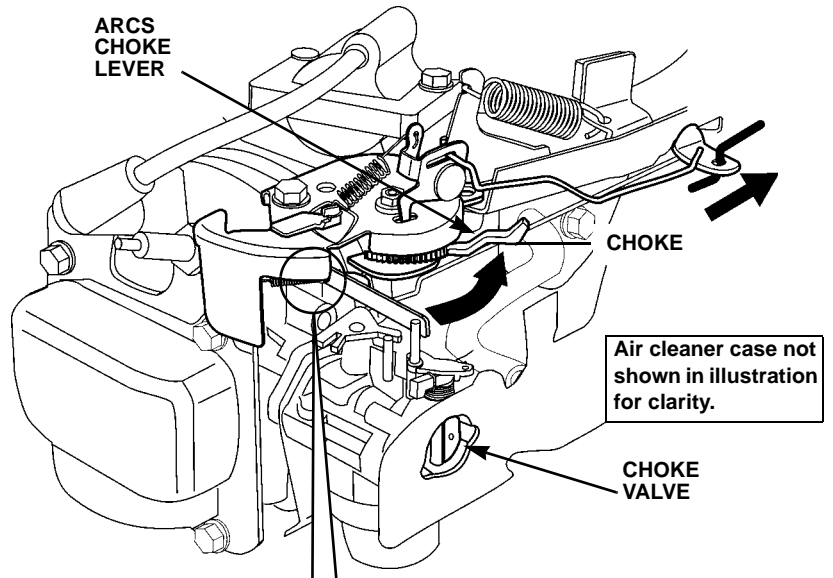

## SERVICE INFORMATION

9. Remove the 6 x 14 and 6 x 16 mm flange bolts, and remove the ARCS assembly while disconnecting the stop rod.

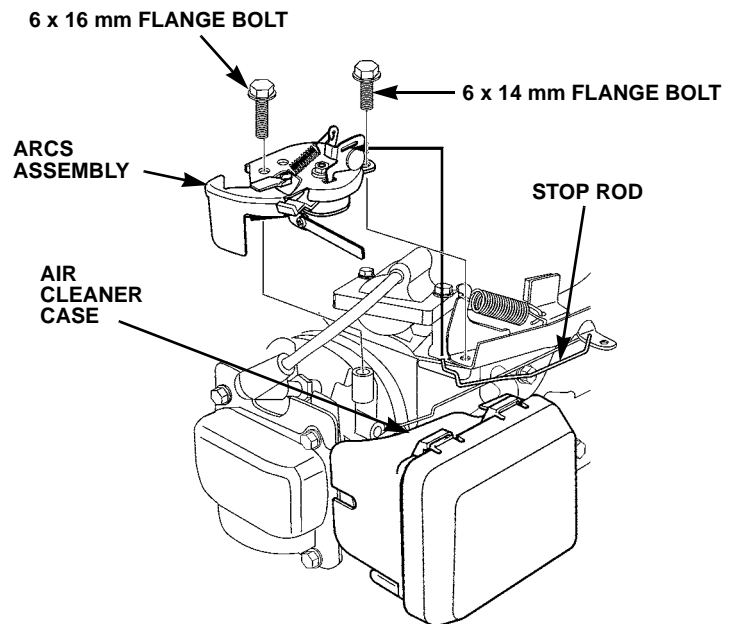

*Perform step 10 only if the ARCS choke lever binds on the air cleaner case in step 8.*

10. Using a sharp utility knife, carefully trim the area from the air cleaner case as shown.

The trimmed area will eliminate the interference with the ARCS cam and allow free motion of the choke lever.

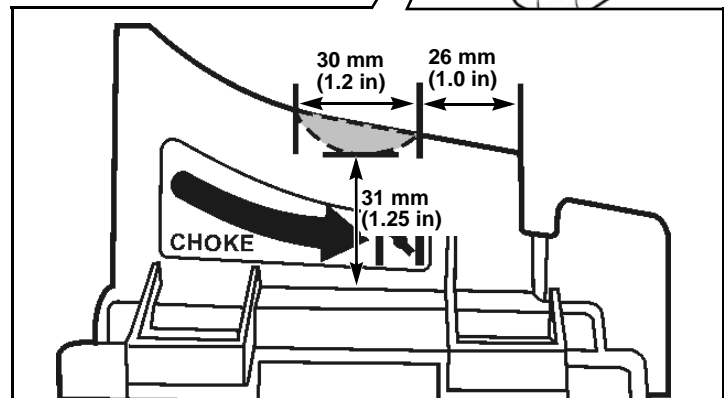
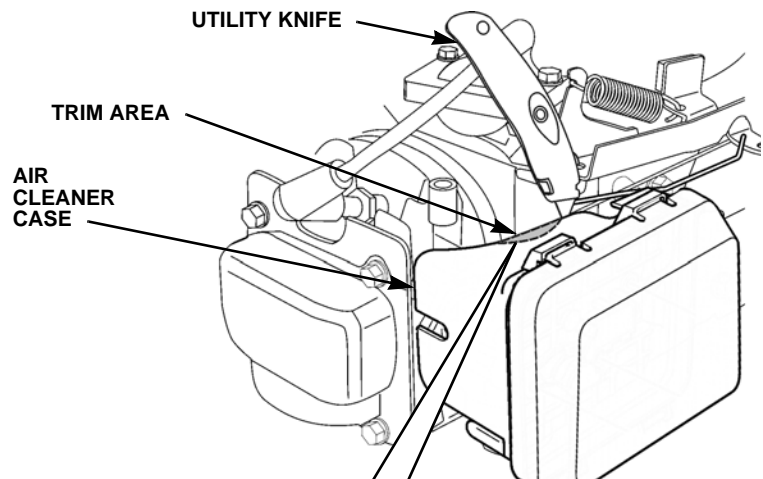

Perform step 11 only if the choke link contacts the cylinder barrel cooling fin in step 8.

- With the ACRS assembly removed, carefully file the cylinder barrel fin until there is clearance between the choke link and the cylinder barrel with the ARCS set in the CHOKE position.

File the cylinder barrel cooling fin here.

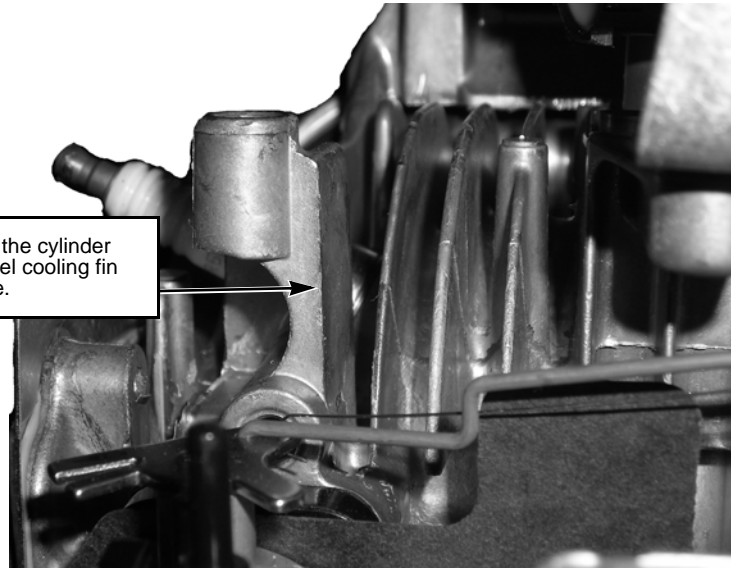

- With the ARCS assembly removed, confirm all parts operate smoothly and no debris is obstructing the function.

If the ARCS assembly does not function properly, it will need to be replaced. Go to step 15.

- Use a shop towel to clean the surface of the knuckle and lever arm where it contacts the knuckle.

Do not spray any solvents directly onto the ARCS assembly as damage may result to plastic and rubber parts. If solvent needs to be applied, spray or dip a shop towel in solvent and clean the surfaces, being careful not to contact the wax motor area.

- Increase the return spring tension by moving the spring hook to the smaller notch position.

- Remove the air cleaner cover and the paper element.

- Loosen the two 6 x 86 mm flange bolts attaching the carburetor. Do not remove the bolts.

With the mounting bolts loosened, push the carburetor to the most forward position possible, being careful not to rotate the carburetor.

- While holding the carburetor in this position, retighten the 6 x 86 mm flange bolts.

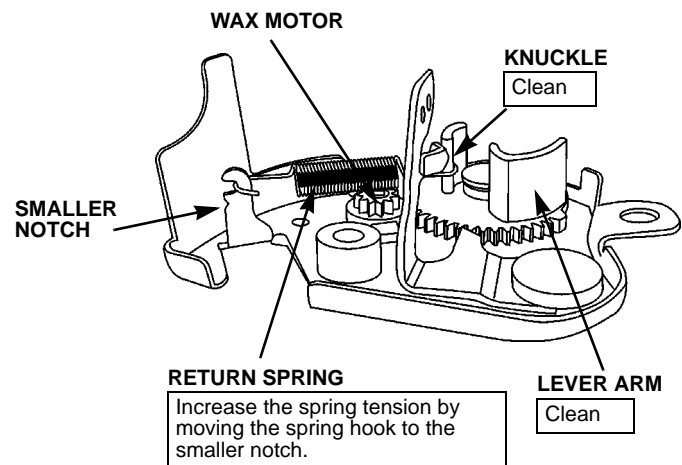

### CARBURETOR ASSEMBLY

Push the carburetor toward the front of the engine.

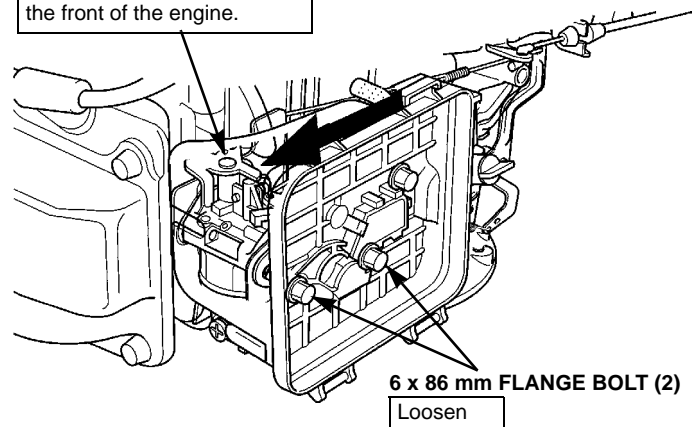

## SERVICE INFORMATION

18. Insert the stop rod into the ARCS assembly.
19. Install the ARCS assembly and the 6 x 14 and 6 x 16 mm flange bolts. Do not tighten the 6 mm flange bolts at this time.  
Verify that the choke plate is to the right of the choke shaft peg to ensure proper choke operation.

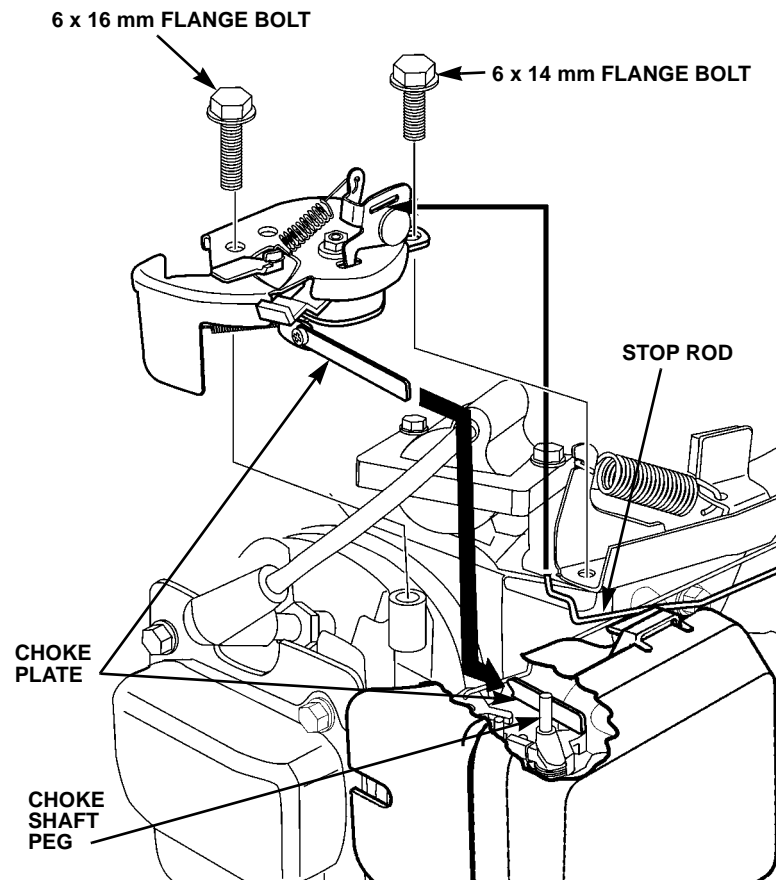

20. Slide the ARCS to the rearmost position and fully tighten the two 6 mm flange bolts.
21. Test the ARCS system for proper operation.
22. Install the fan cover/fuel tank and the recoil starter.
23. Remove and inspect the spark plug. Replace the spark plug if it is fouled.
24. Start the engine and verify that it operates normally.

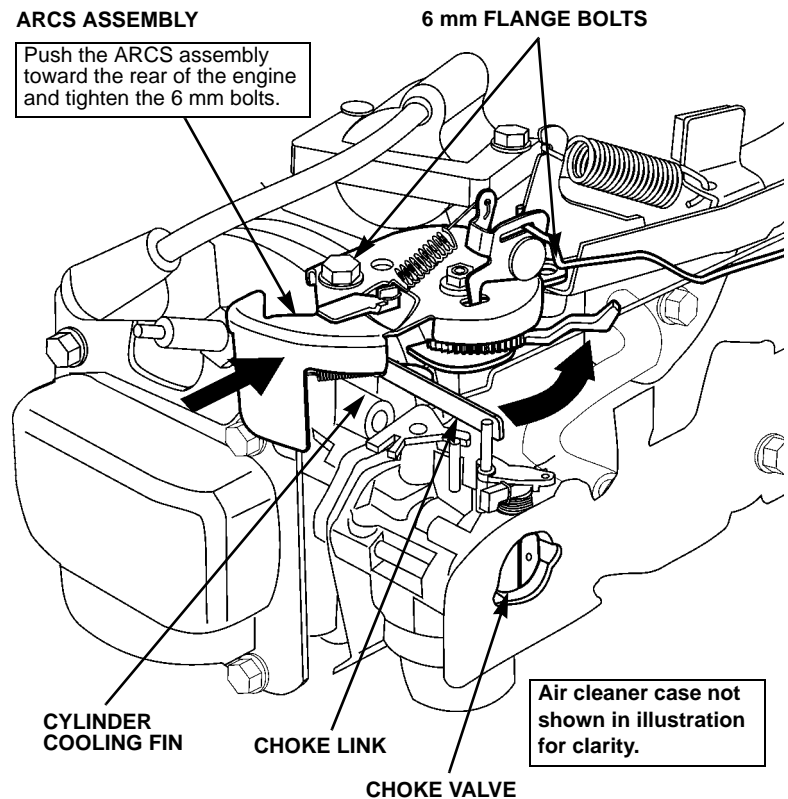

## 8. HARNESS ROUTING

- WITH FLYWHEEL BRAKE

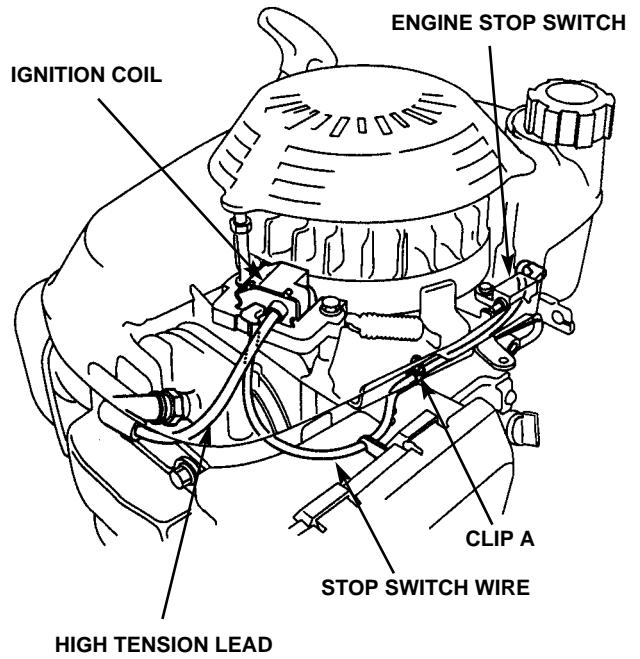
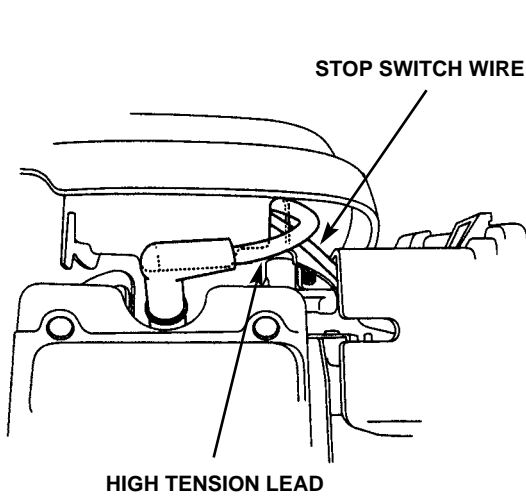

- WITHOUT FLYWHEEL BRAKE

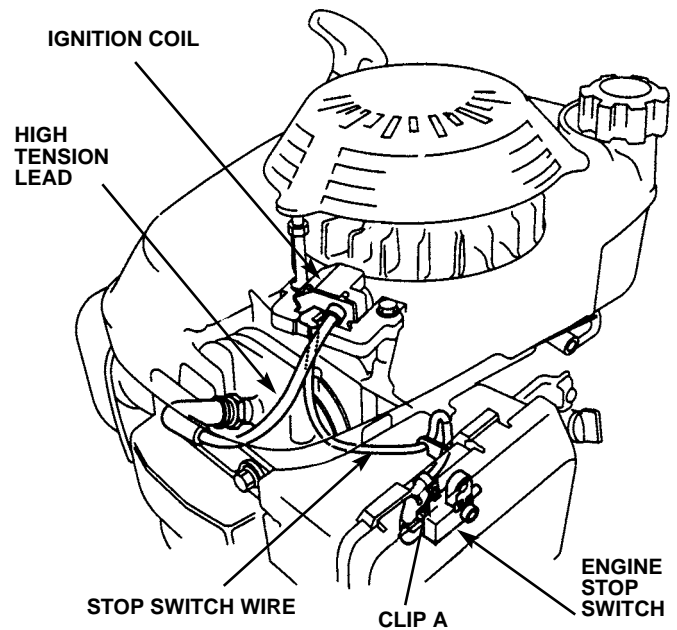
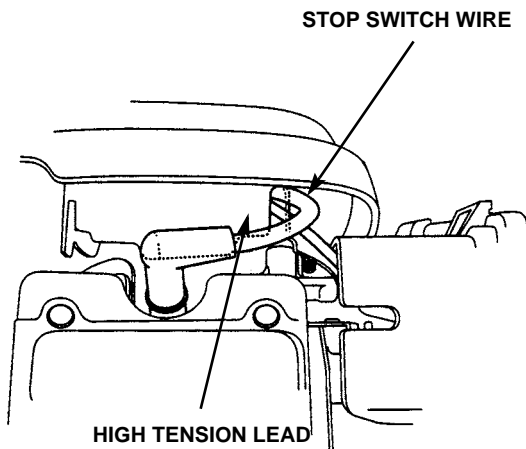

# SERVICE INFORMATION

## CAST-IRON FLYWHEEL TYPES

### • NON-FLYWHEEL BRAKE/FIXED THROTTLE TYPES

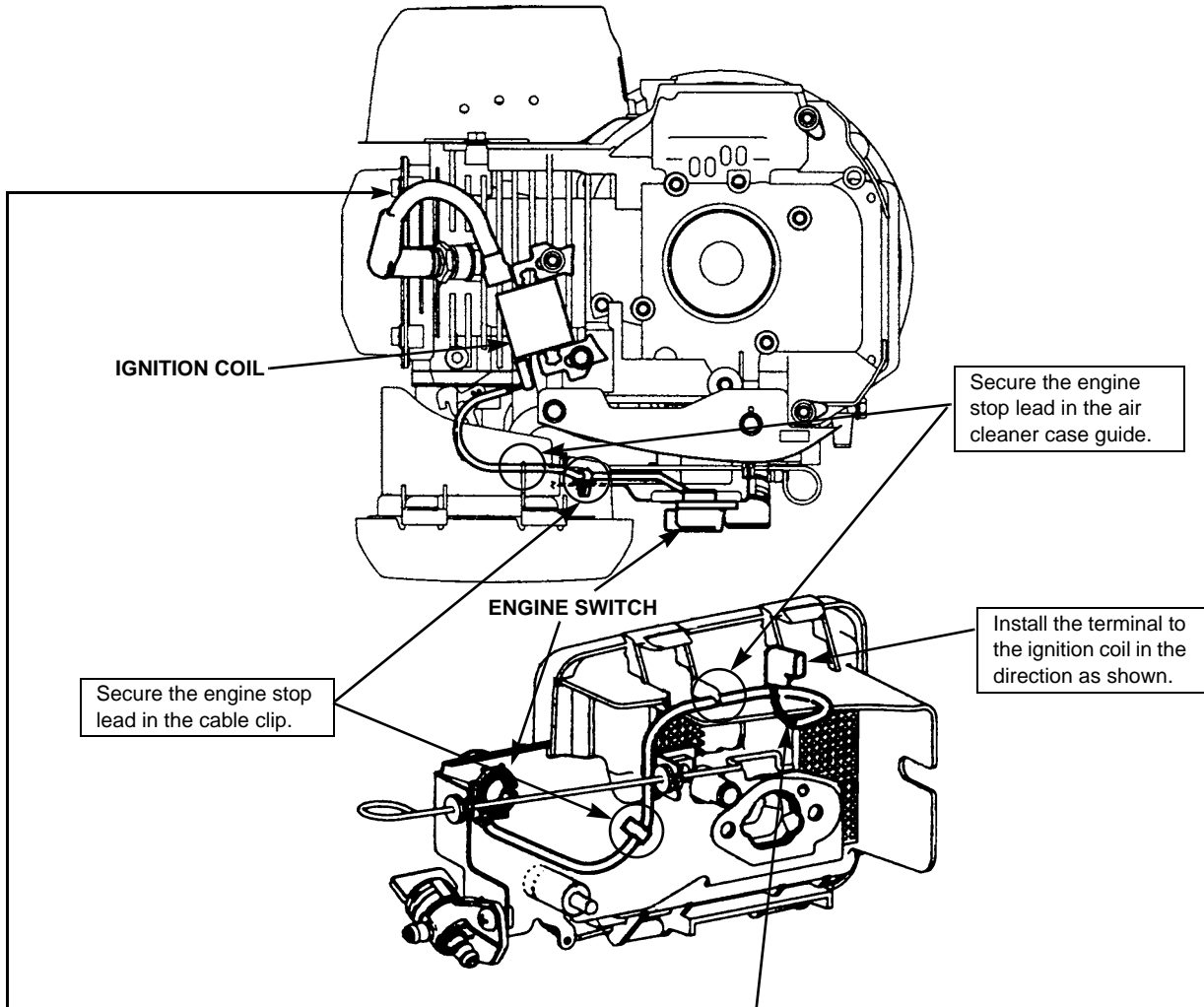

#### HIGH TENSION LEAD

Make sure the high tension lead is completely set in the fan cover air guide cutout.

FAN COVER  
AIR GUIDE  
CUTOUT

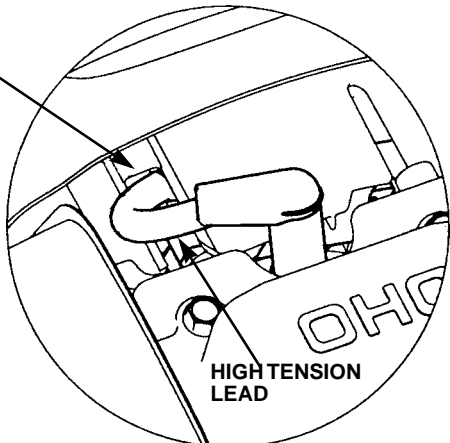

#### STOP SWITCH LEAD

- Make sure the wire is not pinched by the fan cover.
- Make sure the protective tube is installed in the fan cover air guide cutout.

FAN COVER  
AIR GUIDE  
CUTOUT

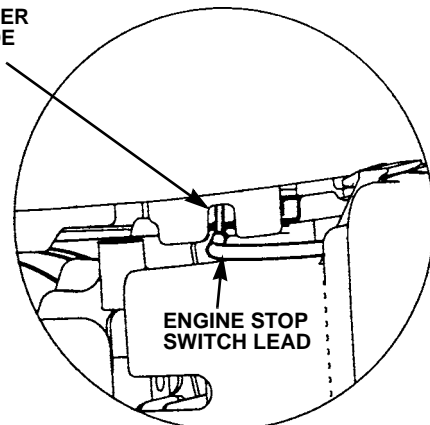

• **NON-FLYWHEEL BRAKE/ADJUSTABLE THROTTLE TYPES**

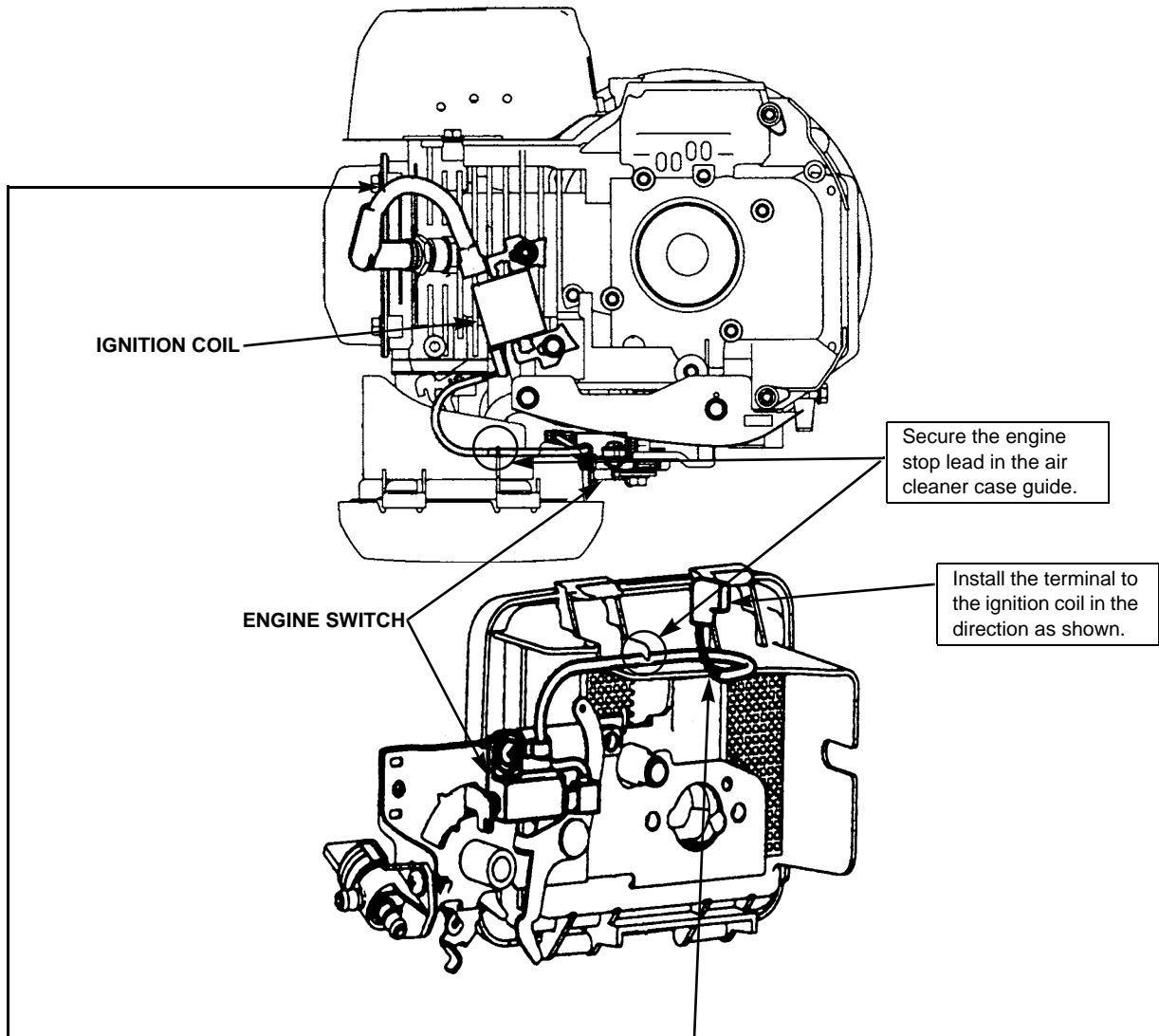

**HIGH TENSION LEAD**

Make sure the high tension lead is completely set in the fan cover air guide cutout.

**FAN COVER  
AIR GUIDE  
CUTOUT**

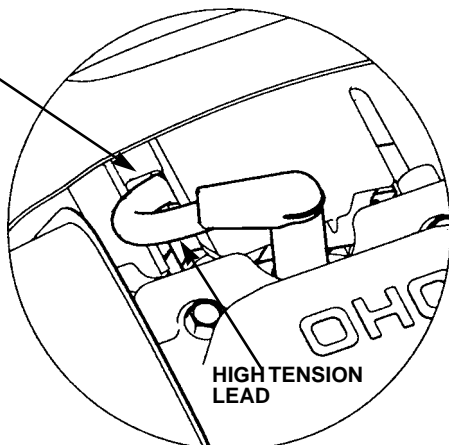

**STOP SWITCH LEAD**

- Make sure the wire is not pinched by the fan cover.
- Make sure the protective tube is installed in the fan cover air guide cutout.

**FAN COVER  
AIR GUIDE  
CUTOUT**

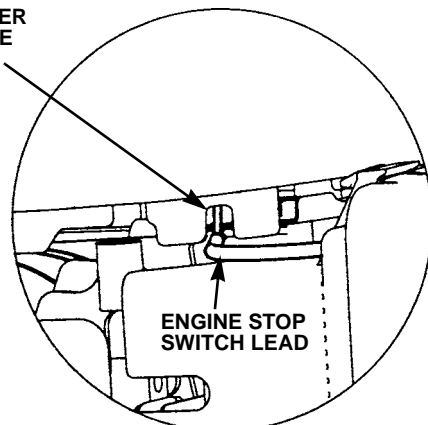



## SERVICE INFORMATION

### ACS (AUTO-CHOKE SYSTEM TYPES) WITH CAST-IRON FLYWHEEL

#### • NON-FLYWHEEL BRAKE/FIXED THROTTLE TYPES

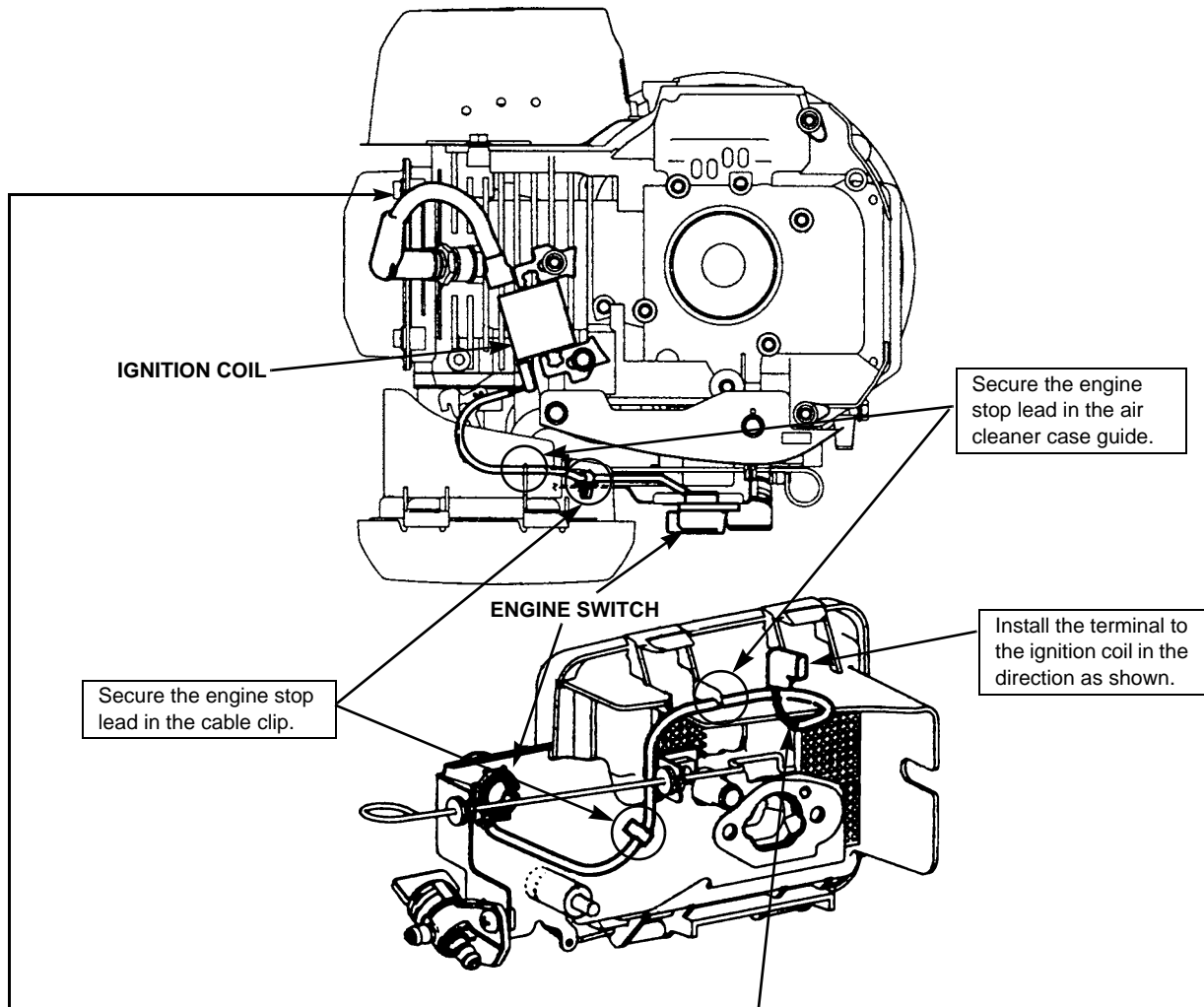

#### HIGH TENSION LEAD

Make sure the high tension lead is completely set in the fan cover air guide cutout.

#### FAN COVER AIR GUIDE CUTOUT

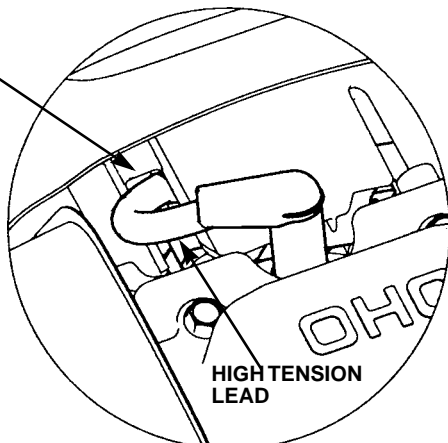

#### STOP SWITCH LEAD

- Make sure the wire is not pinched by the fan cover.
- Make sure the protective tube is installed in the fan cover air guide cutout.

#### FAN COVER AIR GUIDE CUTOUT

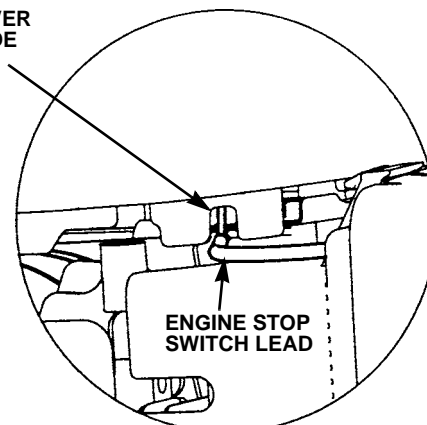

• **NON-FLYWHEEL BRAKE/ADJUSTABLE THROTTLE TYPES**

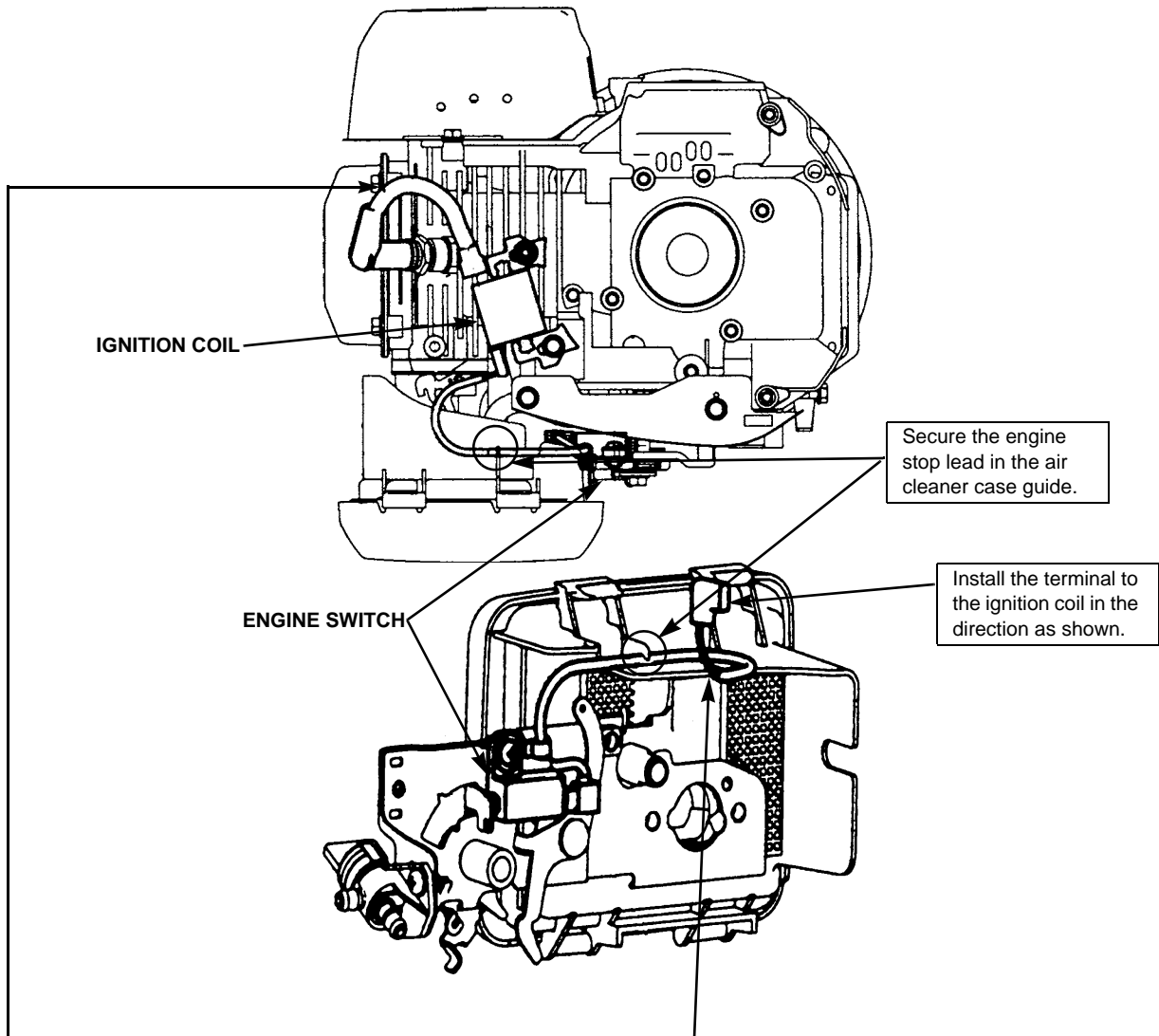

**HIGH TENSION LEAD**

Make sure the high tension lead is completely set in the fan cover air guide cutout.

**FAN COVER  
AIR GUIDE  
CUTOUT**

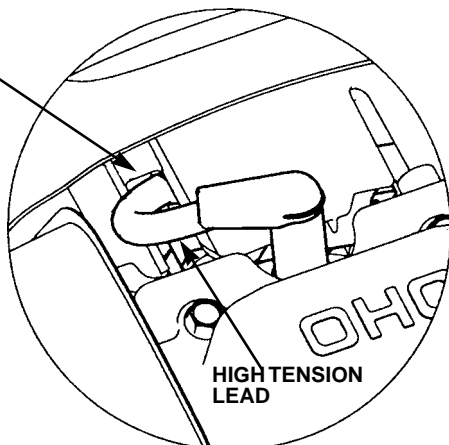

**STOP SWITCH LEAD**

- Make sure the wire is not pinched by the fan cover.
- Make sure the protective tube is installed in the fan cover air guide cutout.

**FAN COVER  
AIR GUIDE  
CUTOUT**

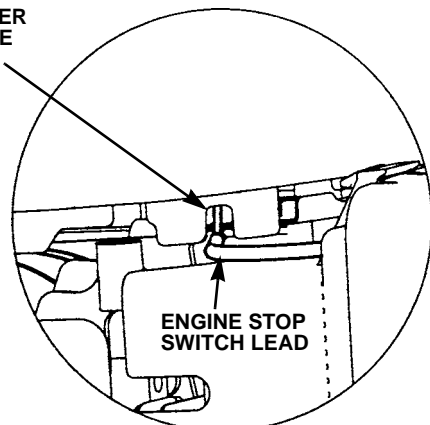

# SERVICE INFORMATION

## • ELECTRIC START TYPE

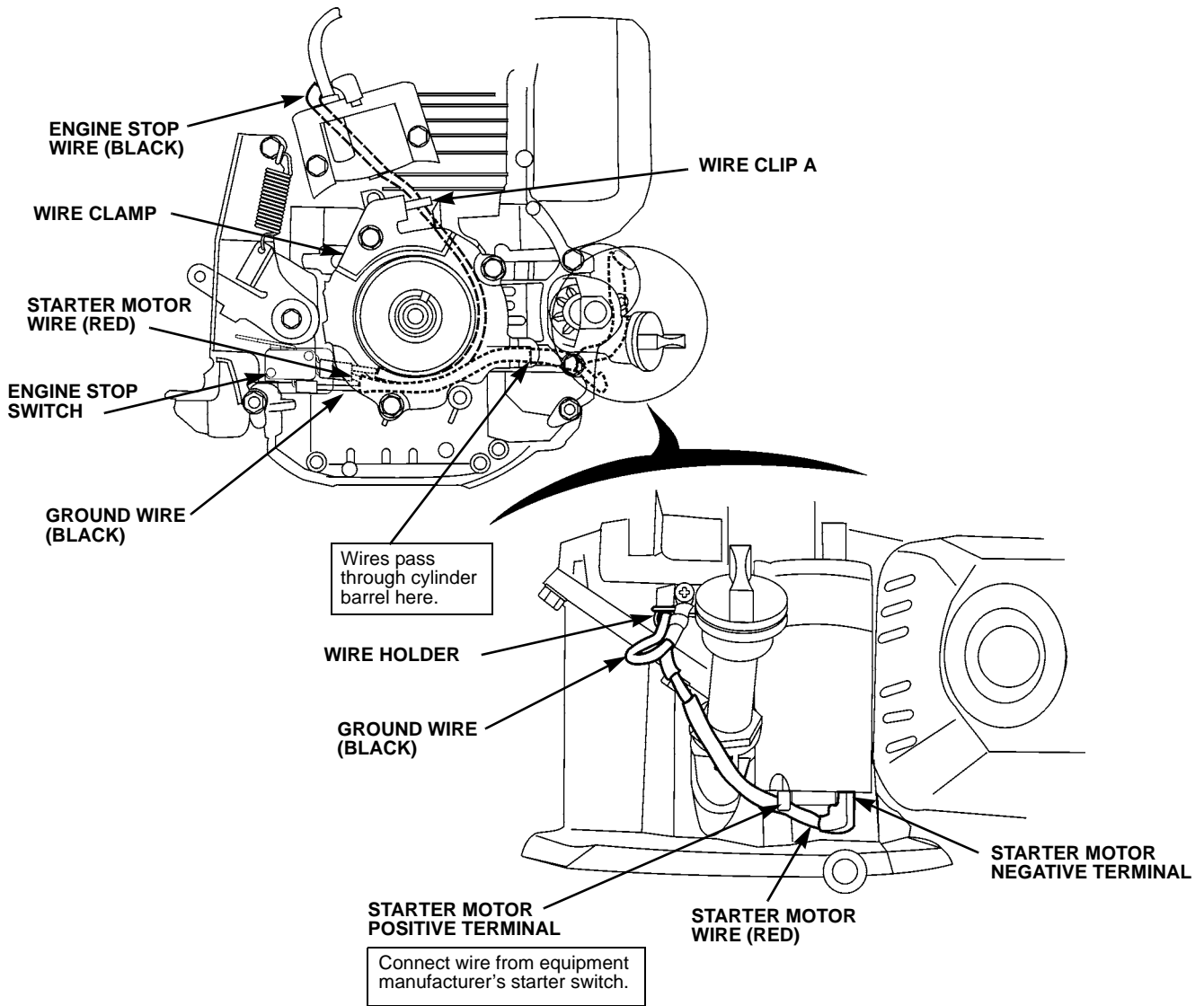

• **CAST-IRON FLYWHEEL/NON-FLYWHEEL BRAKE TYPES**

**FAN COVER AIR GUIDE CUTOUTS**

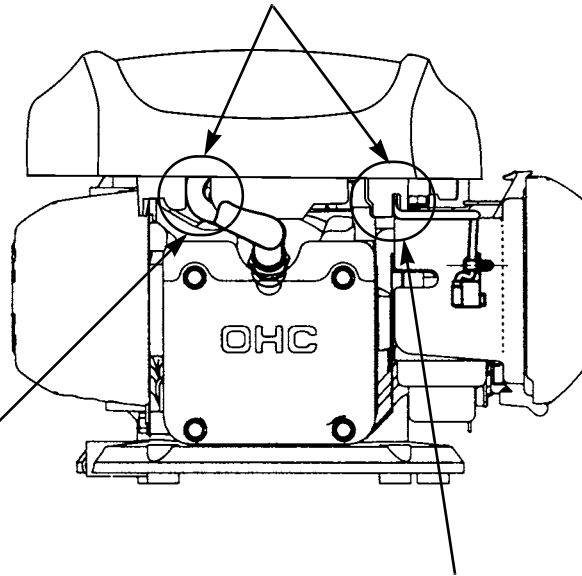

**HIGH TENSION LEAD**

**REASSEMBLY:**

Make sure the high tension lead is completely set in the fan cover air guide cutout.

**FAN COVER AIR GUIDE CUTOUT**

**HIGH TENSION LEAD**

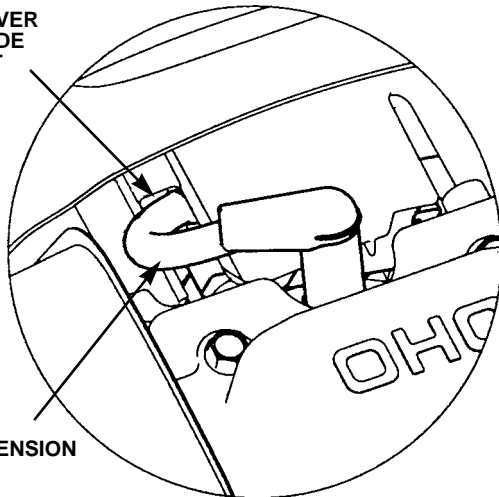

**STOP SWITCH LEAD**

**REASSEMBLY:**

- Make sure the wire is not pinched by the fan cover.
- Make sure the protective tube is installed in the fan cover air guide cutout.

**FAN COVER AIR GUIDE CUTOUT**

**ENGINE STOP SWITCH LEAD**

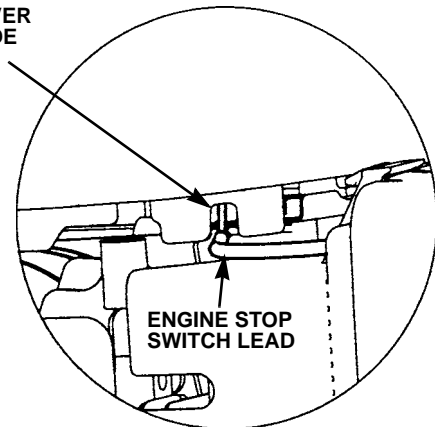

# SERVICE INFORMATION

## • GCV190N5AV AUTO THROTTLE TYPE

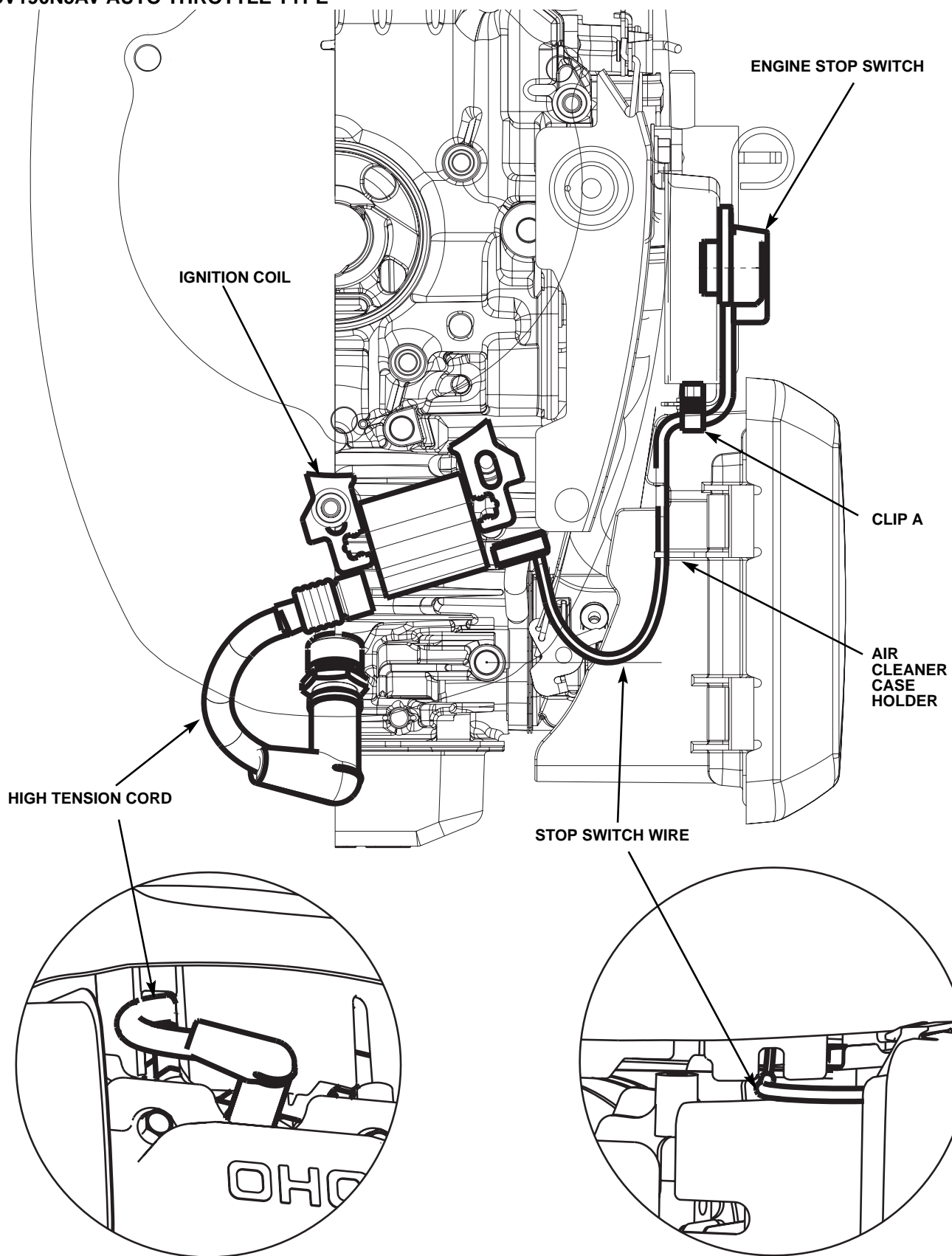

**GCV190N5AV AUTO THROTTLE TYPE (CONTINUED)**

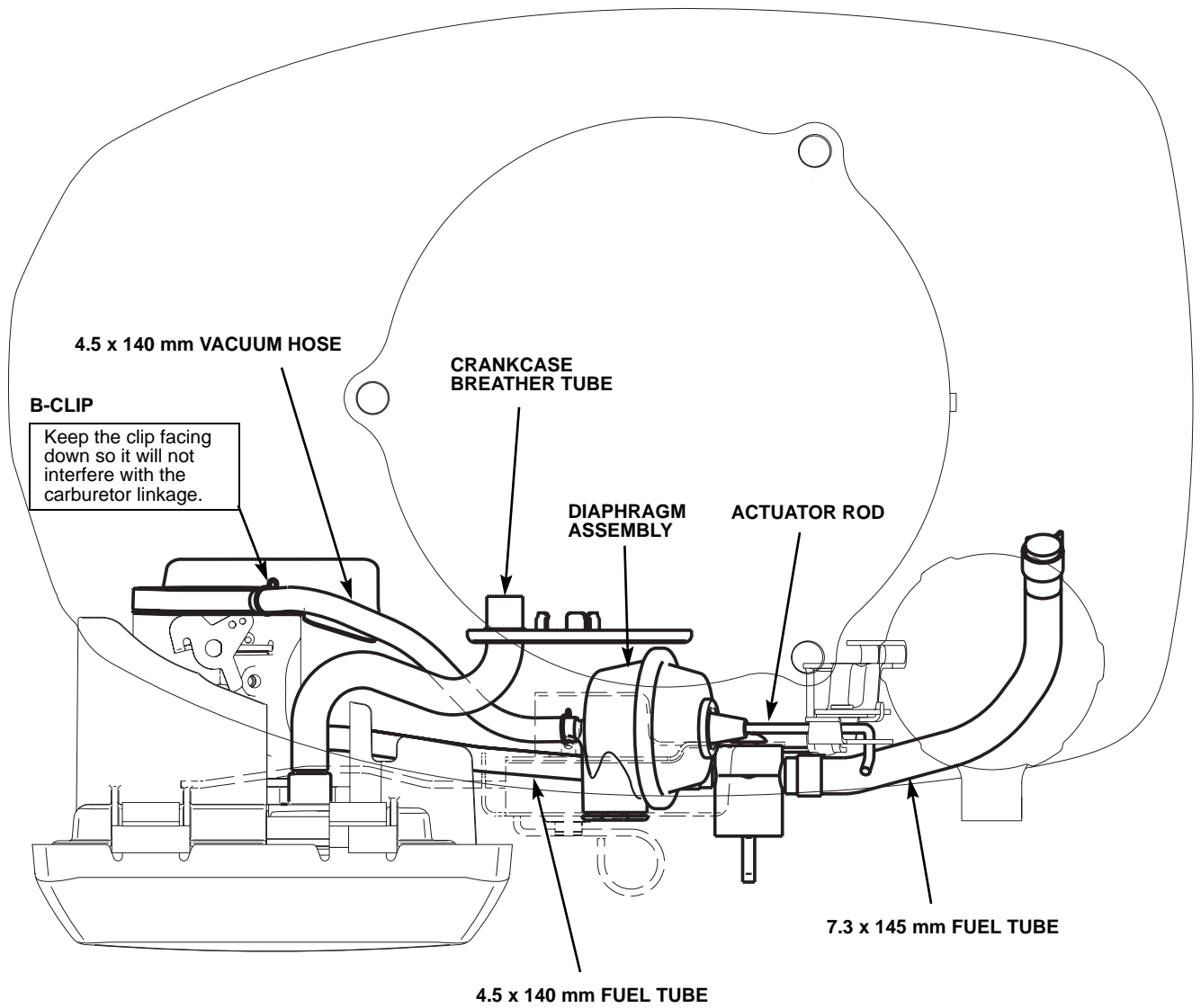

## SERVICE INFORMATION

---

# 3. MAINTENANCE

---

1. MAINTENANCE SCHEDULE . . . . .	3-2	8. VALVE CLEARANCE . . . . .	3-11
2. MAINTENANCE SPECIFICATIONS . . . . .	3-3	9. IDLE SPEED . . . . .	3-13
3. ENGINE TUNE-UP SPECIFICATIONS . . . . .	3-3	10. GOVERNOR . . . . .	3-14
4. ENGINE OIL . . . . .	3-4	11. ROTO-STOP® . . . . .	3-18
5. AIR CLEANER . . . . .	3-6	12. FLYWHEEL BRAKE . . . . .	3-19
6. SPARK PLUG . . . . .	3-9	13. FUEL TANK/FUEL FILTER . . . . .	3-20
7. SPARK ARRESTER . . . . .	3-10	14. COMBUSTION CHAMBER CLEANING . . . . .	3-23



## MAINTENANCE

### 1. MAINTENANCE SCHEDULE

ITEM	Perform at every indicated interval.	REGULAR SERVICE PERIOD						Refer to Page
		Before Each Use	First Month or 5 Hours	First 25 Hours	Every 50 Hours	Every 100 Hours	Every 150 Hours	
Engine oil	Check	O						<a href="#">P. 3-4</a>
	Change		O		O (1)			
Air cleaner	Check	O						<a href="#">P. 3-6</a>
	Clean			O (1)	O (1)			
	Replace filter						O	
Spark plug	Adjust					O		<a href="#">P. 3-10</a>
	Replace						O	
Spark arrester (optional part)	Clean					O		<a href="#">P. 3-10</a>
Valve clearance	Check-Adjust						O	<a href="#">P. 3-11</a>
Idle speed	Check-Adjust						O	<a href="#">P. 3-13</a>
Roto-Stop®	Check operation					O		<a href="#">P. 3-18</a>
	Adjust cable (2)					O		
	Check brake wear					O		
	Check clutch wear					O		
Flywheel brake	Check operation					O		<a href="#">P. 3-19</a>
	Adjust cable (2)					O		
	Check pad wear					O		
Fuel tank and filter	Clean						O	<a href="#">P. 3-20</a>
Fuel tube	Check	Every 2 years (Replace if necessary)						
Combustion chamber	Clean	After every 250 hours						<a href="#">P. 3-23</a>

(1) Service more frequently when used in dusty areas.

(2) Refer to the equipment manufacturer's instructions for cable adjustment procedure (if necessary).

## 2. MAINTENANCE SPECIFICATIONS

Engine oil		Capacity: 0.55 ℓ (0.58 qt) Refill amount: 0.35 ~ 0.40 ℓ (12.0 ~ 13.5 oz) Use SAE 10W-30 for general use.	<a href="#">P. 3-4</a>
Air cleaner		Clean with compressed air, not exceeding 207 kPa (30 psi).	<a href="#">P. 3-6</a>
Spark plug	Type	Lawn mower applications: NGK-BP5RES All others: NGK-BP6RES	<a href="#">P. 3-10</a>
	Gap	0.70 ~ 0.80 mm (0.028 ~ 0.031 in)	
Spark arrester (optional part)		Brush carbon deposits from screen, no breaks or tears	<a href="#">P. 3-10</a>
Valve clearance (cold)		Intake: 0.15 ± 0.04 mm Exhaust: 0.20 ± 0.04 mm	<a href="#">P. 3-11</a>
Carburetor	All others	Idle speed: 1,700 ± 150 rpm	<a href="#">P. 3-13</a>
	GCV190N5AV	Idle speed: 2,350 ~ 2,650 rpm	<a href="#">P. 3-13</a>
Throttle cable and linkage	Adjustable throttle types	Adjust for proper choke operation and maximum governed speed of 2,950 ~ 3,100 rpm.	<a href="#">P. 3-14</a>
	Fixed throttle types	Adjust for maximum governed speed of 2,950 ~ 3,250 rpm.	<a href="#">P. 3-15</a>
	GCV190N5AV	3,650 rpm maximum (loaded) 3,650 ~ 3,850 rpm (unloaded with diaphragm disabled)	<a href="#">P. 3-14</a>
Governor		Adjust so shaft is rotated fully clockwise at full throttle.	<a href="#">P. 3-14</a>
Roto-Stop	Cable	Refer to the equipment manufacturer's instructions for adjustment.	<a href="#">P. 3-18</a>
	Mechanism	Brake wear service limit: 1.5 mm (0.59 in) minimum Clutch wear service limit: 0.5 mm (0.20 in) minimum	
Flywheel brake	Cable	Refer to the equipment manufacturer's instructions for adjustment.	<a href="#">P. 3-19</a>
	Mechanism	Brake shoe thickness service limit: 3.0 mm (0.12 in)	
Fuel tank and filter		Back flush with nonflammable solvent.	<a href="#">P. 3-20</a>
Fuel tube		Replace if damaged or deteriorated.	<a href="#">P. 3-21</a>

## 3. ENGINE TUNE-UP SPECIFICATIONS

Spark plug gap		0.7 ~ 0.8 mm (0.028 ~ 0.031 in)	<a href="#">P. 3-10</a>
Engine idle speed	All others	1,700 ± 150 rpm	<a href="#">P. 3-13</a>
	GCV190N5AV	2,350 rpm minimum	<a href="#">P. 3-13</a>
Valve clearance (cold)		Intake: 0.15 ± 0.04 mm Exhaust: 0.20 ± 0.04 mm	<a href="#">P. 3-11</a>
Other specifications		No other adjustments needed.	

## MAINTENANCE

### 4. ENGINE OIL

#### a. INSPECTION

##### • Without Oil Filler Extension Types

1. Remove the oil filler cap, and wipe the dipstick clean.
2. Insert the dipstick in the oil filler neck, but do not screw it in.
3. Remove the dipstick and check the oil level.
4. Add the recommended oil ([P. 3-5](#)) to the upper limit mark on the dipstick, with the dipstick fully inserted but not screwed in. Do not overfill.
5. Tighten the oil filler cap securely.

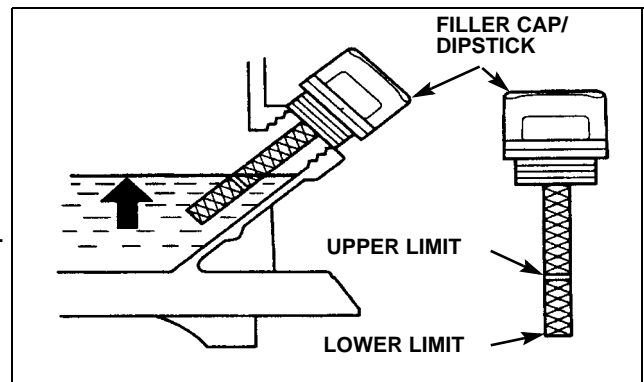

##### • With Oil Filler Extension Types

Check the engine oil level with the engine stopped and the engine on a level surface.

1. Remove the oil filler cap/dipstick, and wipe the dipstick clean.
2. Insert the dipstick in the oil filler neck, but do not screw it in.
3. Remove the dipstick and check the oil level.
4. Add the recommended oil ([P. 3-5](#)) to the upper limit mark on the dipstick, with the dipstick fully inserted but not screwed in. Do not overfill.
5. Tighten the oil filler cap/dipstick securely.

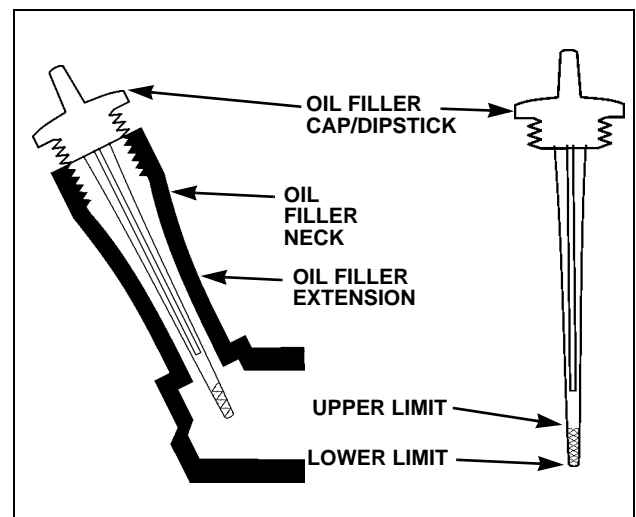
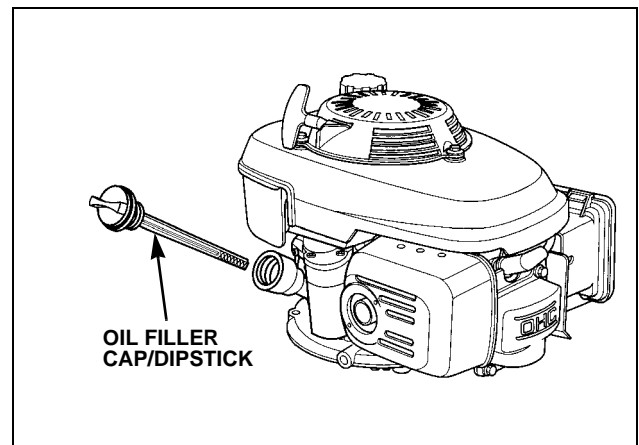

**b. OIL CHANGE**

1. Check that the fuel tank cap is tightened securely.
2. Remove the oil filler cap. Tilt the engine toward the oil filler cap side and drain the used oil into a suitable container.

Please dispose of used motor oil in a manner that is compatible with the environment. We suggest you take used oil in a sealed container to your local recycling center or service station for reclamation. Do not throw it in the trash or pour it on the ground or pour it down a drain.

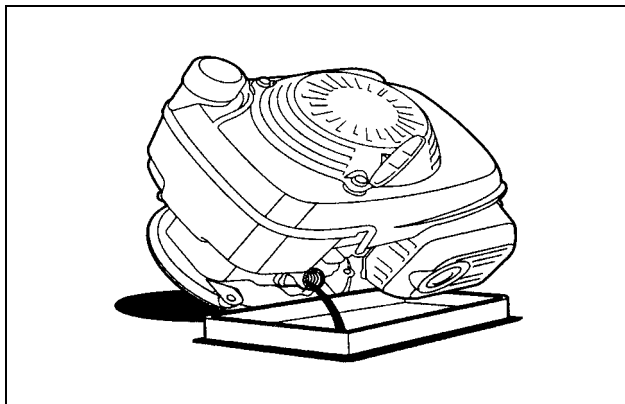

<b>▲ CAUTION</b>
<p>Used engine oil contains substances that have been identified as carcinogenic.</p> <p>If repeatedly left in contact with the skin for prolonged periods, it may cause skin cancer.</p> <p>Wash your hands thoroughly with soap and water as soon as possible after contact with used engine oil.</p>

3. Refill with the recommended oil to the upper limit mark on the dipstick. Check oil level with the mower on a level surface, and the dipstick fully inserted but not screwed in.

Engine oil capacity	0.55 ℓ (18.6 oz) Refill amount: 0.35 ~ 0.40 ℓ (12.0 ~ 13.5 oz)
---------------------	--

Oil is a major factor affecting performance and service life. Use 4-stroke automotive detergent oil.

SAE 10W-30 is recommended for general use. Other viscosities shown in the chart may be used when the average temperature in your area is within the recommended range.

The SAE oil viscosity and service classification are given in the API label on the oil container. Honda recommends that you use API service category SJ or later oil.

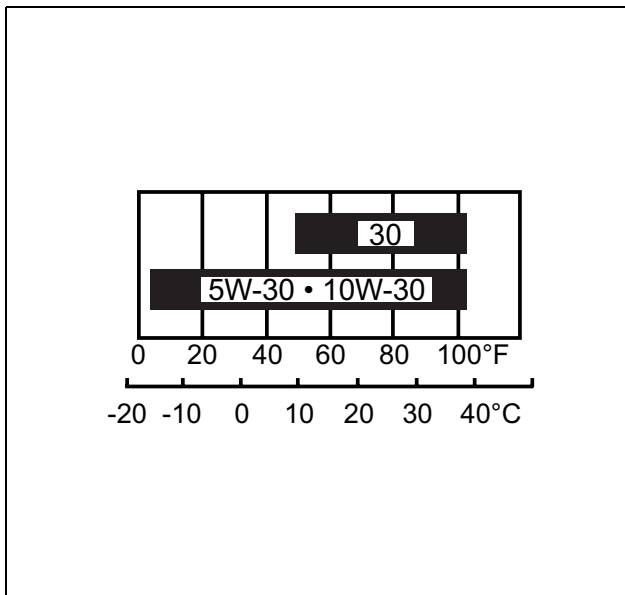

## MAINTENANCE

### 5. AIR CLEANER

#### CLEANING

- GCV135/160/190

A dirty air filter will restrict air flow to the carburetor, reducing engine performance. If the engine is operated in dusty areas, clean the air filter more often than specified in the MAINTENANCE SCHEDULE.

#### NOTICE

*Operating the engine without an air filter or with a damaged air filter will allow dirt to enter the engine, causing rapid engine wear. This type of damage is not covered by the Distributor's Limited Warranty.*

1. Press the latch tabs on the top of the air cleaner and remove the air cleaner cover.
2. Remove the paper air filter from the air cleaner case.
3. Inspect the air filter and replace it if it is damaged.
4. Clean the filter. Tap the filter several times on a hard surface to remove dirt, or blow with compressed air (not exceeding 207 kPa [30 psi]) through the filter from the inside. Never try to brush off dirt; brushing will force dirt into the fibers.
5. Wipe dirt from the inside of the air cleaner housing and cover, using a moist rag.

Be careful to prevent dirt from entering the air duct leading to the carburetor.

6. Reinstall the filter and air cleaner cover.

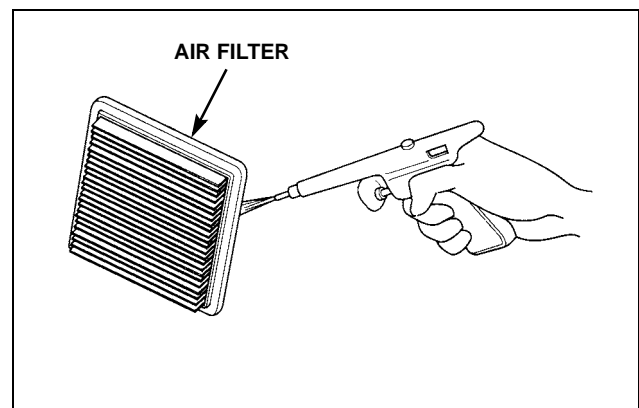
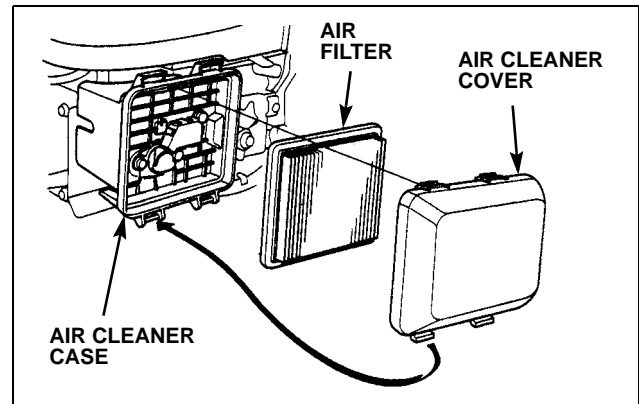

• **GSV190**

A dirty air filter will restrict air flow to the carburetor, reducing engine performance. If the filter is operated in dusty areas, clean the air filter more often than specified in the MAINTENANCE SCHEDULE.

**NOTICE**

*Operating the engine without an air filter or with a damaged air filter, will allow dirt to enter the engine, causing rapid engine wear. This type of damage is not covered by the Distributor's Limited Warranty.*

1. Press the latch tabs on the top of the air cleaner cover, and remove the cover.
2. Remove the foam element from the air cleaner cover.
3. Remove the screen grid from the paper element.
4. Inspect the paper element, and replace if damaged.

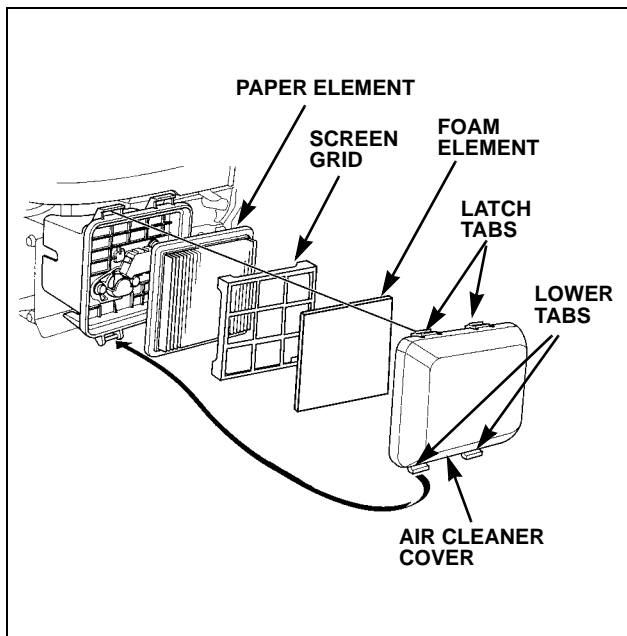

5. Paper Element: Tap the filter several times on a hard surface to remove dirt, or blow compressed air [not exceeding 207 kPa (30 psi)] through the filter from the clean side that faces the engine.

Never try to brush off dirt; brushing will force dirt into the fibers.

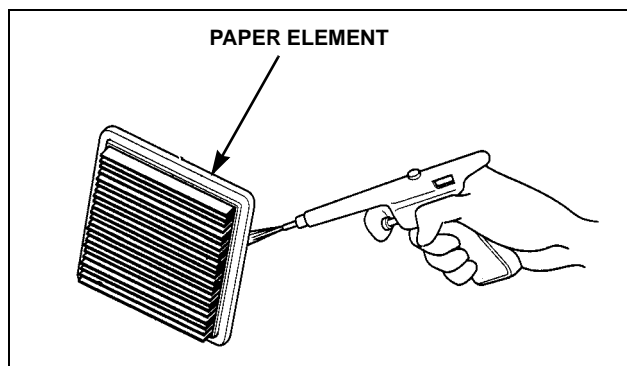

Foam Element: Wash the element in a solution of household detergent and warm water, then rinse thoroughly, or wash in nonflammable or high flash point solvent. Allow the element to dry thoroughly.

Soak the element in clean engine oil and squeeze out the excess oil. The engine will smoke during initial start-up if too much oil is left in the foam, or the oil could saturate the paper element, making the engine inoperable.

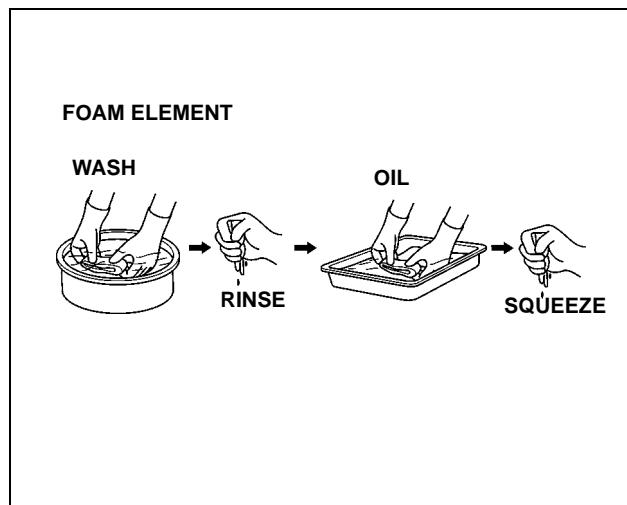

## MAINTENANCE

6. Wipe dirt from the inside of the air cleaner cover and air cleaner case, using a moist rag. Be careful to prevent dirt from entering the air duct that leads to the carburetor.
7. Reinstall the screen grid over the paper element. Make sure that the screen grid completely surrounds the paper pleats.
8. Reinstall the foam element in the air cleaner cover.
9. Set the paper element and screen grid in the air cleaner case, and then install the air cleaner cover.
10. Reinstall the air cleaner cover by locking the lower tabs in the bottom of the air cleaner body and snapping the latch tabs in the top of the air cleaner body.

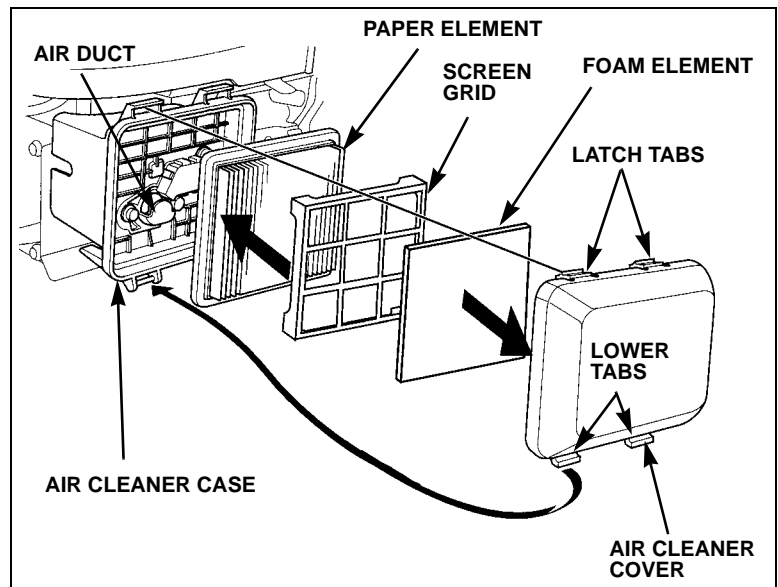

## 6. SPARK PLUG

### INSPECTION

Recommended spark plug	Pressure washer applications: NGK BPR6ES All others: NGK BPR5ES
------------------------	--

An incorrect spark plug can cause engine damage. Use the recommended spark plug or an exact equivalent.

1. Visually inspect the spark plug. Discard the plug if the insulator is cracked or chipped.
2. Measure the plug gap with a wire-type gauge. If necessary, adjust the gap by bending the side electrode.

Spark plug gap	0.7 ~ 0.8 mm (0.028 ~ 0.031 in)
----------------	---------------------------------

3. Make sure the sealing washer is in good condition and replace if necessary.
4. Install the plug finger-tight to seat the washer, and then tighten with a plug wrench to compress the sealing washer:  
Tighten a new plug 1/2 turn after the plug seats.  
Tighten a reused plug 1/8 ~ 1/4 turn after the plug seats.

#### NOTICE

*A loose spark plug can overheat and damage the engine. Overtightening can damage the threads in the cylinder head.*

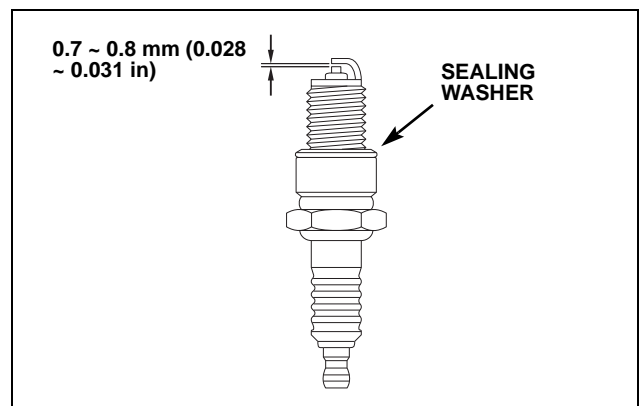
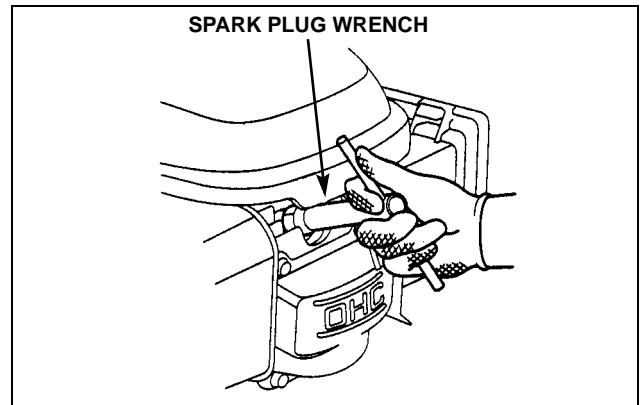



## MAINTENANCE

### 7. SPARK ARRESTER (optional part)

#### CLEANING

The spark arrester must be serviced every 100 hours to keep it functioning as designed.

1. Remove the three flange bolts from the muffler protector.
2. Remove the self-tapping screw from the spark arrester, and remove the spark arrester from the muffler. Be careful not to damage the spark arrester screen.
3. Check for carbon deposits around the exhaust port and spark arrester. Clean with a wire brush, if necessary. Replace the spark arrester if there are any breaks or tears.
4. Install the spark arrester and muffler protector in the reverse order of disassembly.

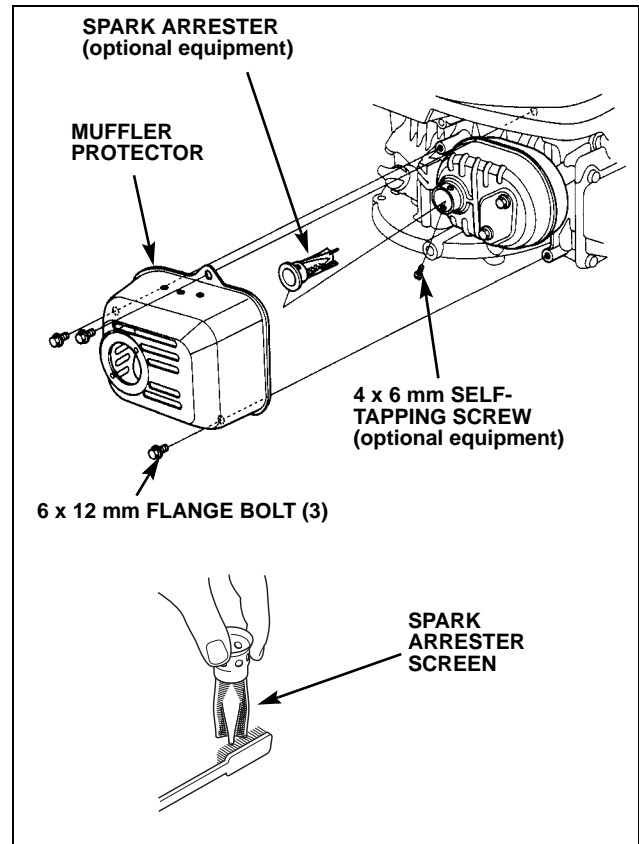

## 8. VALVE CLEARANCE

### INSPECTION/ADJUSTMENT

Valve clearance inspection and adjustment must be performed with the engine cold.

1. Remove the spark plug cap from the spark plug.
2. Remove the fan cover/fuel tank (P. 6-21).
3. Remove the four flange bolts from the cylinder head cover. GSV190: Remove and replace the cylinder head cover gasket.
4. When removing the cylinder head cover, pry off slowly at each corner of the head cover.

#### NOTICE

*Using too much force can deform the cylinder head cover. The cylinder head cover must be replaced if it is deformed.*

5. *Aluminum flywheel types:* Rotate the engine until the cam lobe is pointing away from the flywheel. Align the flywheel arrow alignment mark with the right rear fan cover/fuel tank mounting stud.

This will set the piston at top dead center of the compression stroke (both valves are fully closed).

*Cast-iron flywheel types:* Align the edge of the flywheel magnet with the fan cover/fuel tank mounting stud as shown,

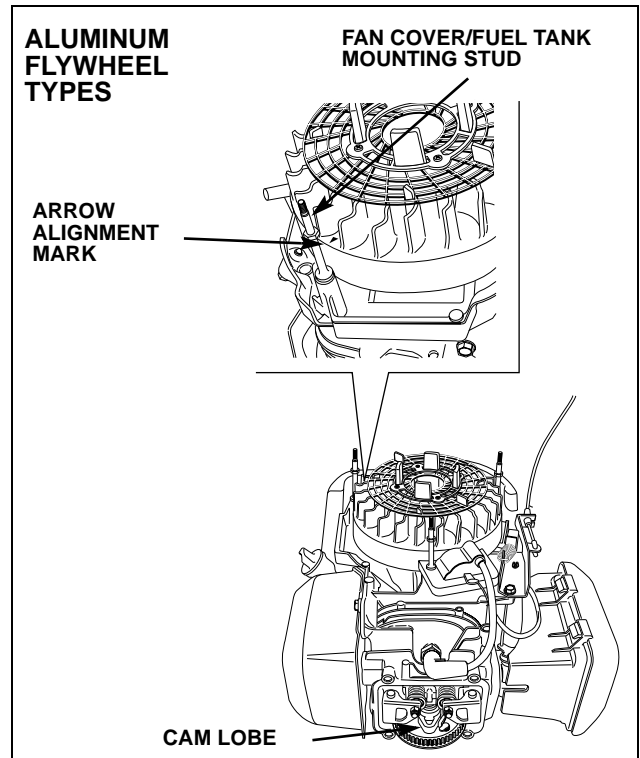
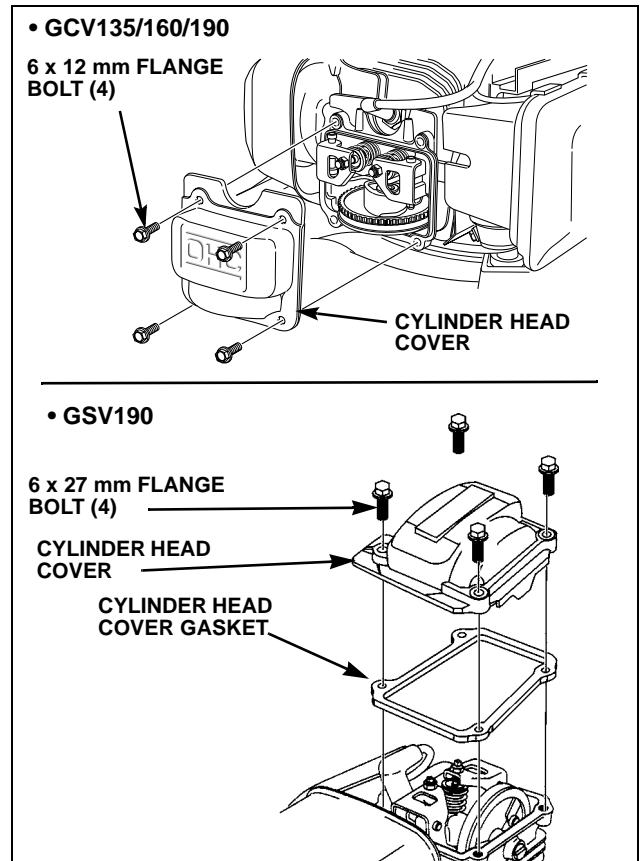
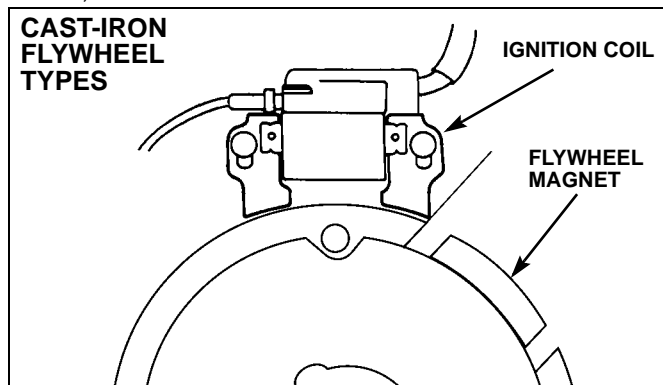

## MAINTENANCE

6. Insert a feeler gauge between the valve stem and the adjusting screw on the rocker arm.

Standard valve clearance (cold)	IN	$0.15 \pm 0.04$ mm
	EX	$0.20 \pm 0.04$ mm

### TOOL:

Valve adjustment wrench, 3 mm 07908-KE90200

7. If adjustment is necessary:
- Hold the adjustment screw using the special tool, and loosen the lock nut.
  - Turn the adjustment screw to obtain the specified intake and exhaust valve clearance.
  - Hold the adjusting screw using the special tool, and tighten the lock nut.

**TORQUE: 8 N•m (5.8 ft-lb)**

Recheck valve clearance after tightening the lock nut.

8. Apply liquid gasket (Hondabond HT, Three Bond 1216, or equivalent) to the cylinder head cover sealing surface, and install the cylinder head cover (P. 8-3).  
GSV190: Install a new cylinder head cover gasket when installing the cylinder head cover (P. 8-3).

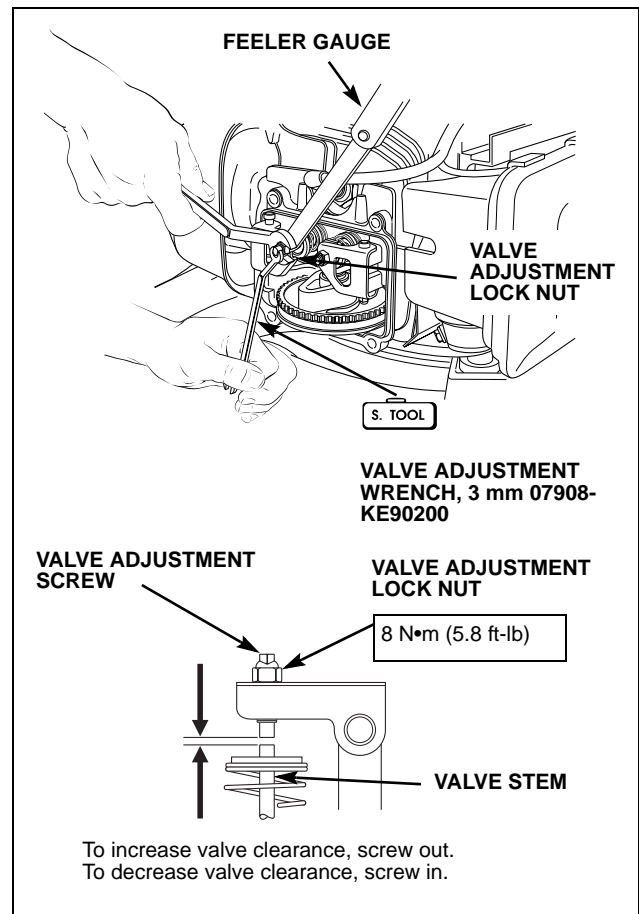

## 9. IDLE SPEED

This procedure is for adjustable throttle types. It does not apply to fixed-throttle types.

Start the engine in an area with adequate ventilation to avoid carbon monoxide poisoning. Allow the engine to warm up to normal operating temperature. Set the throttle lever in the SLOW position before performing carburetor adjustments.

### a. PILOT SCREW

The pilot screw is fitted with a limiter cap that prevents excessive enrichment of the air-fuel mixture.

Do not attempt to remove the limiter cap for pilot screw adjustment. The limiter cap cannot be removed without breaking the pilot screw.

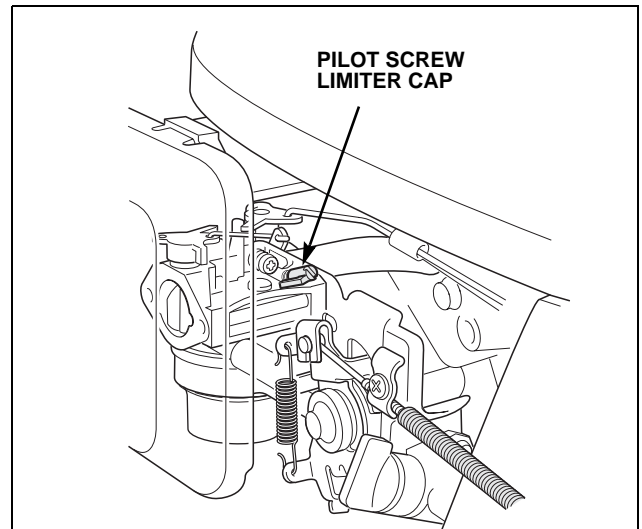

### b. THROTTLE STOP SCREW

Adjust the throttle stop screw to obtain the specified idle speed.

Engine idle speed	All others	1,700 ± 150 rpm
	GCV190N5AV	2,350 rpm minimum

- On fixed-throttle applications, the idle speed cannot be adjusted.
- The standard idle speed may vary depending on the application. Refer to the equipment manufacturer's recommendation for the idle speed specification.

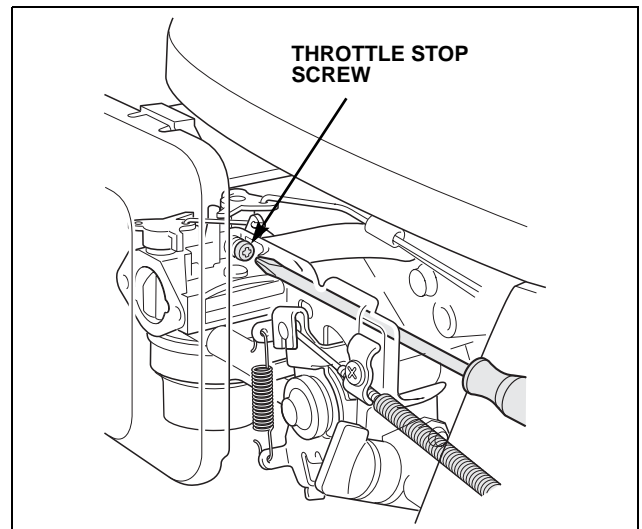

# MAINTENANCE

## 10. GOVERNOR

### ADJUSTMENT

#### Adjustable-Throttle Types

1. With the engine stopped, loosen the governor arm nut.
2. Push the governor arm away from the carburetor to fully open the carburetor throttle valve. Hold the governor arm and carburetor throttle valve in the fully open position, and turn the governor arm shaft fully clockwise; then tighten the governor arm nut.

**TORQUE: 9.8 N•m (7.2 ft-lb)**

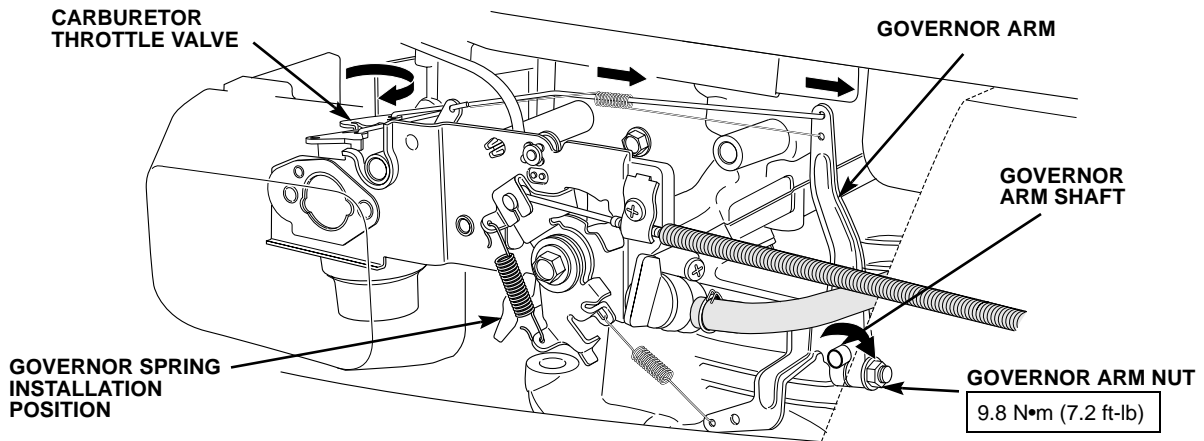

3. Check to make sure the governor arm and the carburetor throttle valve operate smoothly.
4. Check the clearance between the choke arm and control lever.

Clearance	0 ~ 1 mm (0 ~ 0.040 in)
-----------	-------------------------

5. Start the engine and warm it up to the normal operating temperature.  
Move the throttle lever to the FAST position, and check the maximum governed speed.
6. On lawn mower applications, have an assistant hold the flywheel brake or blade brake control lever while you perform the maximum engine speed adjustment.

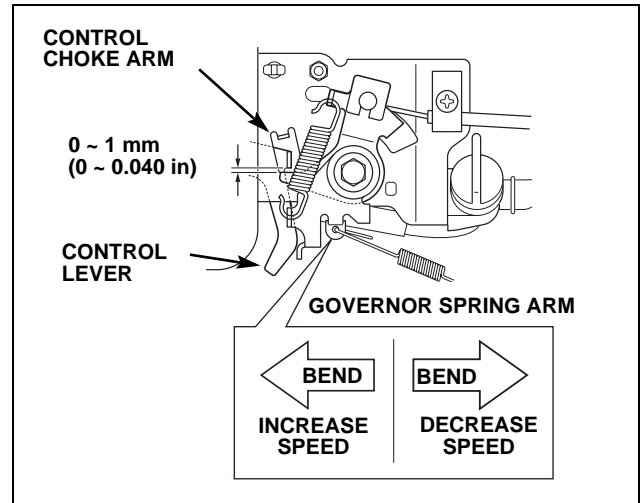

### **⚠ DANGER**

The blades are rotating during this procedure. The rotating blades can cause amputation. Do not allow your hands or feet to come into contact with the rotating blades while performing this procedure.

Maximum governed speed	2,950 ~ 3,100 rpm
------------------------	-------------------

7. If the engine speed is not within specification, bend the governor spring arm very slightly as needed:
  - Left increases spring tension and engine speed.
  - Right decreases spring tension and engine speed.

## Fixed Throttle Types

### • Throttle Control Plate Type

1. Loosen the governor arm nut on the governor arm.
2. Push the governor arm away from the carburetor to open the carburetor throttle valve fully.
3. Holding the carburetor throttle valve fully open, turn the governor arm shaft clockwise fully, and tighten the governor arm nut to the specified torque.

**TORQUE: 10 N•m (7 ft•lb)**

4. Check to see whether the governor arm and the carburetor throttle valve arm operate smoothly.
5. Start the engine and warm it up to the normal operating temperature. Check the maximum engine speed.

Maximum speed (no load)	3,100 ± 150 rpm
-------------------------	-----------------

6. If adjustment is necessary, bend the governor spring tab on the throttle control plate very slightly.
  - Left increases spring tension and engine speed.
  - Right decreases spring tension and engine speed.

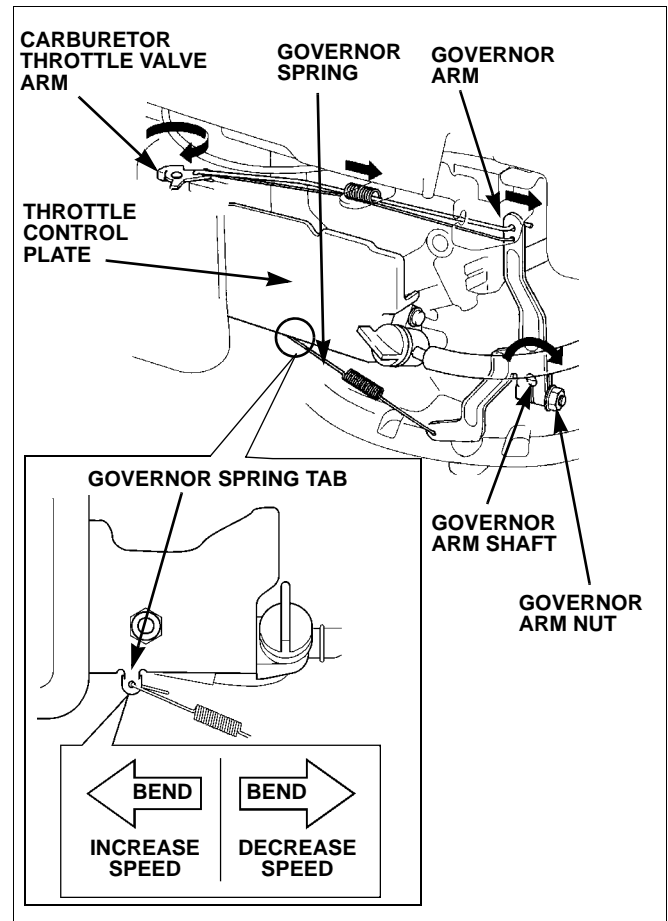

### • Without Throttle Control Plate Type

1. Loosen the governor arm nut on the governor arm.
2. Push the governor arm away from the carburetor to open the carburetor throttle valve fully.
3. Holding the carburetor throttle valve fully open, turn the governor arm shaft clockwise fully, and tighten the governor arm nut to the specified torque.

**TORQUE: 10 N•m (7 ft•lb)**

4. Check to see whether the governor arm and the carburetor throttle valve arm operate smoothly.
5. Start the engine and warm it up to the normal operating temperature. Check the maximum engine speed.

Maximum speed (no load)	3,100 ± 150 rpm
-------------------------	-----------------

6. If adjustment is necessary, bend the governor spring tab on the fuel valve plate very slightly.
  - Left increases spring tension and engine speed.
  - Right decreases spring tension and engine speed.

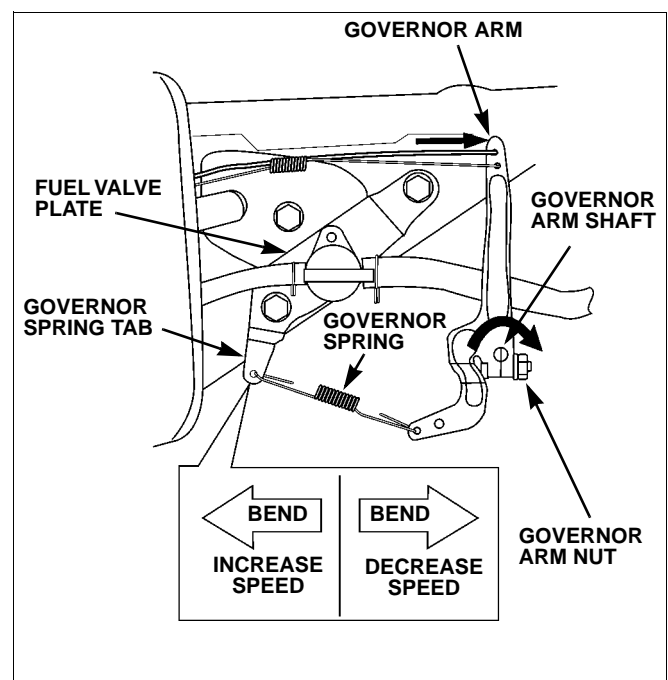

## MAINTENANCE

### GCV190N5AV AUTO THROTTLE

1. With the engine stopped, loosen the governor arm nut.
2. Insert a 2.5 mm rod in the governor arm as shown.
3. Push the governor arm away from the carburetor to fully open the carburetor throttle valve. Hold the governor arm and carburetor throttle valve in the fully open position, and turn the governor arm shaft fully clockwise; then tighten the governor arm nut.

#### **TORQUE: 9.8 N•m (7.2 ft-lb)**

- Verify that the upper and lower portions of the governor arm are contacting at the location shown.
- Verify that the diaphragm rod is located between the alignment marks on the governor arm.
- Check that the governor arm and governor rod do not contact the cylinder barrel.

Check the governor arm for wear if the above conditions cannot be met.

4. Check to make sure the governor arm and the carburetor throttle valve operate smoothly.

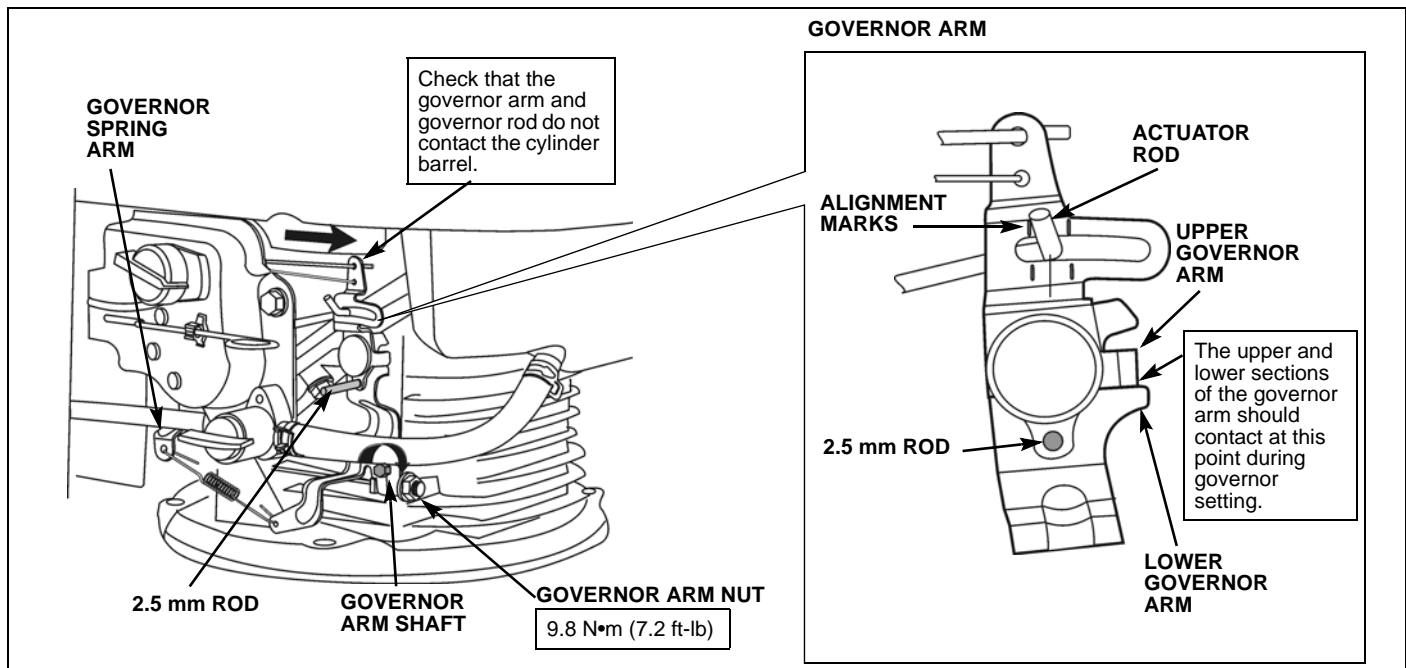

5. Clamp the vacuum hose with pinching pliers so the engine will not go to the idle position.
6. Start the engine and warm it up to the normal operating temperature.

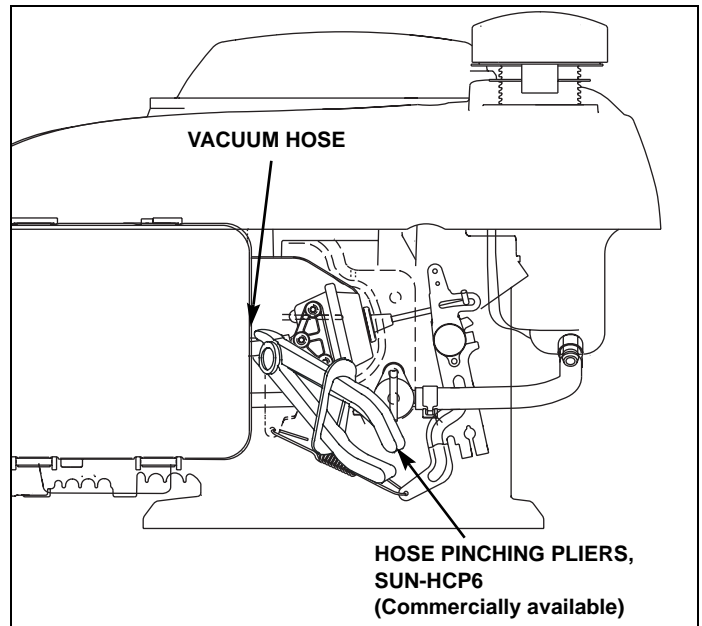

7. Check the engine speed. If it is not within specification, bend the governor spring arm very slightly as needed:
  - Left increases spring tension and engine speed.
  - Right decreases spring tension and engine speed.

Maximum governed speed	3,650 ~ 3,850 rpm (unloaded)
------------------------	------------------------------

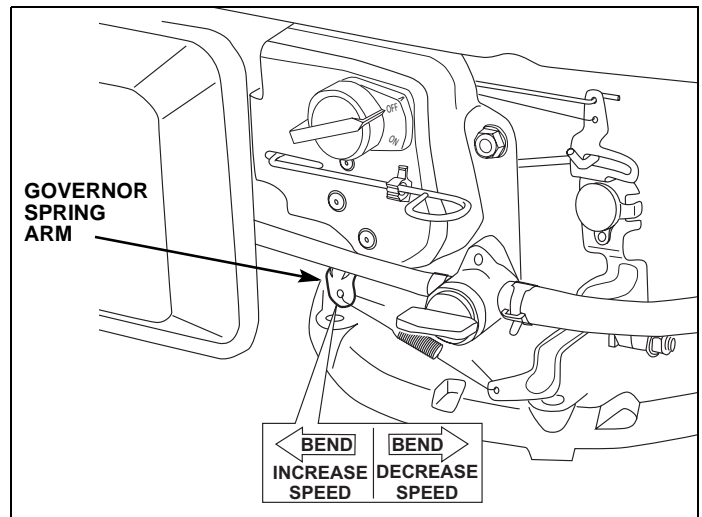



# MAINTENANCE

## 11.ROTO-STOP®

### a. CABLE ADJUSTMENT

Refer to the equipment manufacturer's instructions for performing cable adjustment.

### b. INSPECTION

Before inspecting brake or clutch wear, it is important to make sure the blade control lever free play is correct.

If any measurements are less than the service limit, replace the driven disc and inspect the clutch spring (P. 9-1).

If the clutch spring is not within specifications, replace the clutch spring (P. 9-1).

#### BRAKE WEAR

With the blade control lever released, measure the distance between the edge of the brake plate and the indicator.

	Standard	Service limit
Brake	2.5 mm (0.10 in)	1.5 mm (0.059 in)

Blades have been removed for clarity.

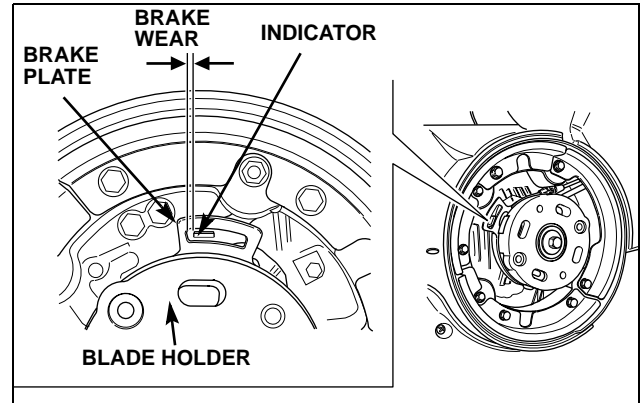

#### CLUTCH WEAR

With the blade control lever pushed forward against the handlebar, use a clean feeler gauge to measure the distance between the brake plate and the driven disc.

	Standard	Service limit
Clutch	2.0 mm (0.08 in)	0.5 mm (0.20 in)

Blades have been removed for clarity.

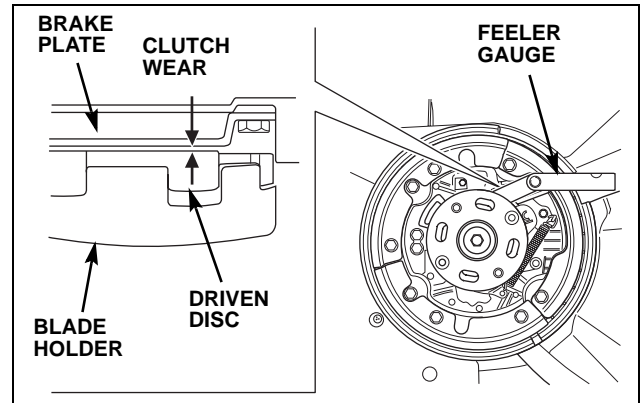

## 12.FLYWHEEL BRAKE

### a. CABLE ADJUSTMENT

Refer to the equipment manufacturer's instructions for performing cable adjustment.

Start the engine outdoors. Move the throttle lever to the FAST position (if equipped) and release the flywheel brake lever; the engine should stop quickly.

### b. INSPECTION

To inspect the flywheel brake shoe lining thickness:

1. Remove the recoil starter ([P. 5-1](#)).
2. Remove the fan cover/fuel tank ([P. 6-21](#)).
3. Measure the thickness of the brake shoe lining. If the brake shoe lining thickness is less than the service limit, replace the brake shoe.

	Standard	Service limit
Brake lining	6 mm (0.24 in)	3.0 mm(0.12 in)

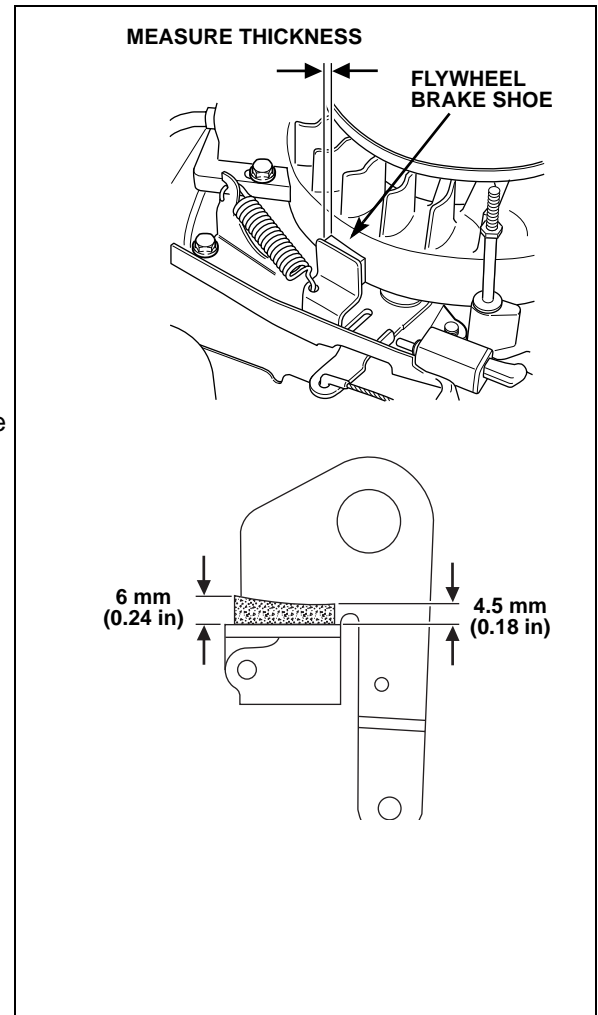

## MAINTENANCE

### 13. FUEL TANK/FUEL FILTER

#### a. FUEL TANK DRAINING AND CLEANING

##### • One-Piece Fan Cover/Fuel Tank

### ⚠ WARNING

Gasoline is highly flammable and explosive.  
You can be burned or seriously injured when handling fuel.

- Keep heat, sparks, and flame away.
- Handle fuel only outdoors.
- Wipe up spills immediately.

1. Turn the fuel valve to the OFF position.
2. Remove the carburetor drain bolt, if equipped, and drain the fuel bowl into an approved container.  
  
Loosen the carburetor bowl set bolt if not equipped with a drain bolt.
3. Turn the fuel valve to the ON position, and allow the remaining fuel in the tank to fully drain.
4. Remove the recoil starter ([P. 5-1](#)).
5. Disconnect the fuel tube from the fuel valve. Do not pry against the fuel valve with a screwdriver or other tool when removing the fuel tube ([P. 6-24](#)).

### NOTICE

*If the fuel tube is pried off the fuel valve with a tool, the fuel valve may become damaged.*

6. Remove the fan cover/fuel tank ([P. 6-21](#)).

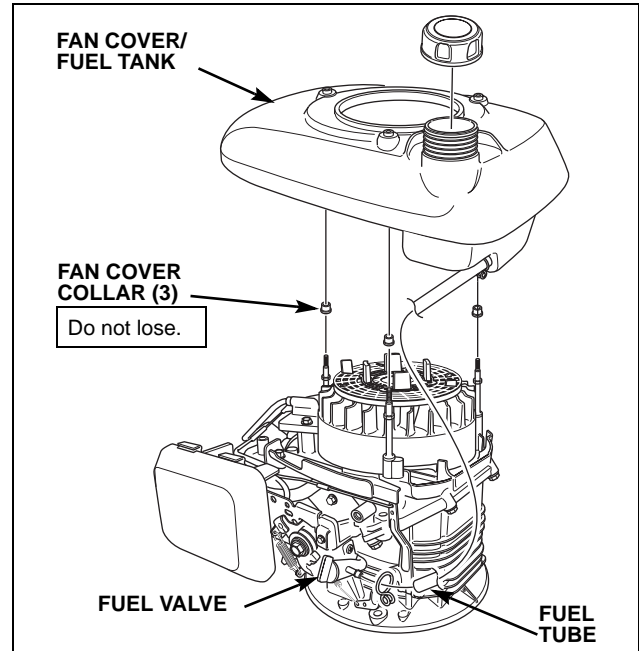
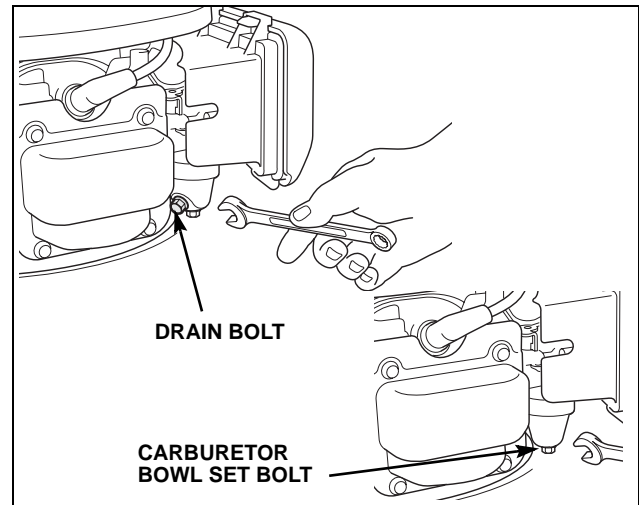

7. Clean the fuel tank. Remove dust and foreign material from the filter by running solvent through the outlet tube.
8. Connect the fuel tube to the fuel outlet valve and install the fan cover/fuel tank.
9. Connect the fuel tube to the fuel valve. After assembly, check for fuel leaks.

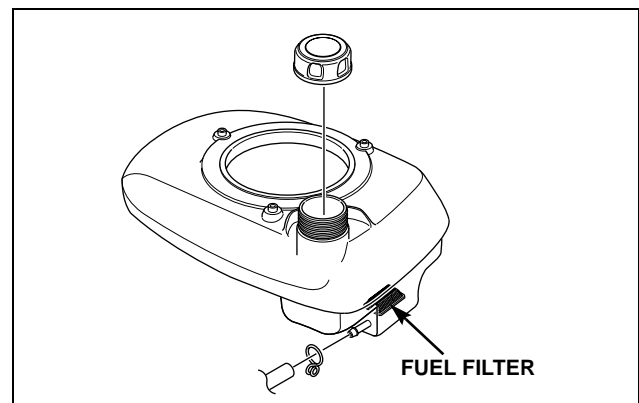

## • Two-Piece Fuel Tank and Fan Cover

### **⚠ WARNING**

Gasoline is highly flammable and explosive. You can be burned or seriously injured when handling fuel.

- Keep heat, sparks, and flame away.
- Handle fuel only outdoors.
- Wipe up spills immediately.

1. Turn the fuel valve to the OFF position.
2. Remove the carburetor drain bolt, if equipped, and drain the fuel bowl into an approved container.

Loosen the carburetor bowl set bolt if not equipped with a drain bolt.

3. Turn the fuel valve to the ON position, and allow the remaining fuel in the tank to fully drain.
4. Slide the tube clip back on the fuel tube.
5. Rotate the fuel tube to help release the tube from the fuel tank, and then pull the tube from the tank fitting.

### **NOTICE**

*Do not pry against the fuel tank with a screwdriver or other tool, or the fuel tank may become damaged.*

6. Remove the fuel strainer from the fuel tube.
7. Inspect the fuel strainer for sediment and other foreign material. Inspect for tears or other damage.
8. Wash with solvent to clean, and dry thoroughly before installation. Replace if necessary.
9. If the fuel strainer is dirty, remove and clean the fuel tank.
10. Insert the fuel strainer into the fuel tank fitting.
11. Connect the fuel tube to the fuel tank fitting.
12. Position the fuel tube clip over the fuel tank fitting.  
After assembly, check for fuel leaks.

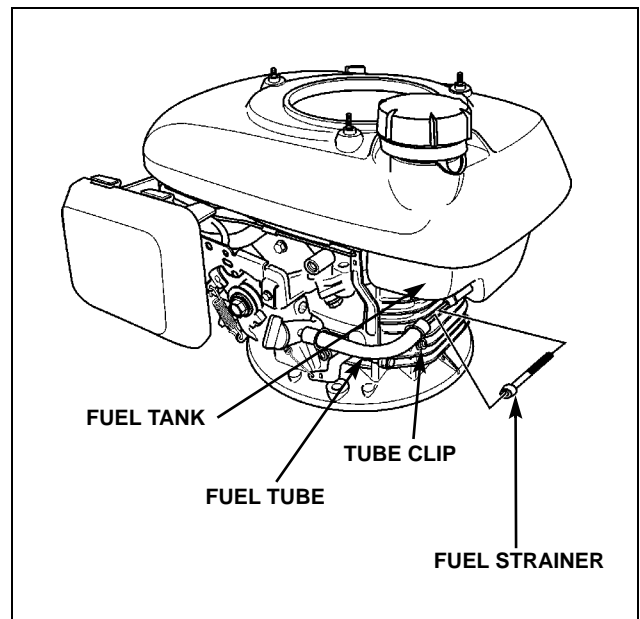

## MAINTENANCE

### b. FUEL TUBE INSPECTION

1. Check the fuel tubes for deterioration, cracks, or signs of leakage. Replace the fuel tubes as necessary.
2. Drain the fuel into a suitable container.

Replace the fuel tube with the correct fuel tube. If the fuel tube has "D" style tube clamps, and has the CARB Executive Order on the fuel tube, the fuel tube is low-permeable to meet 2007 Emission Standards and must be replaced with low-permeable fuel tubes.

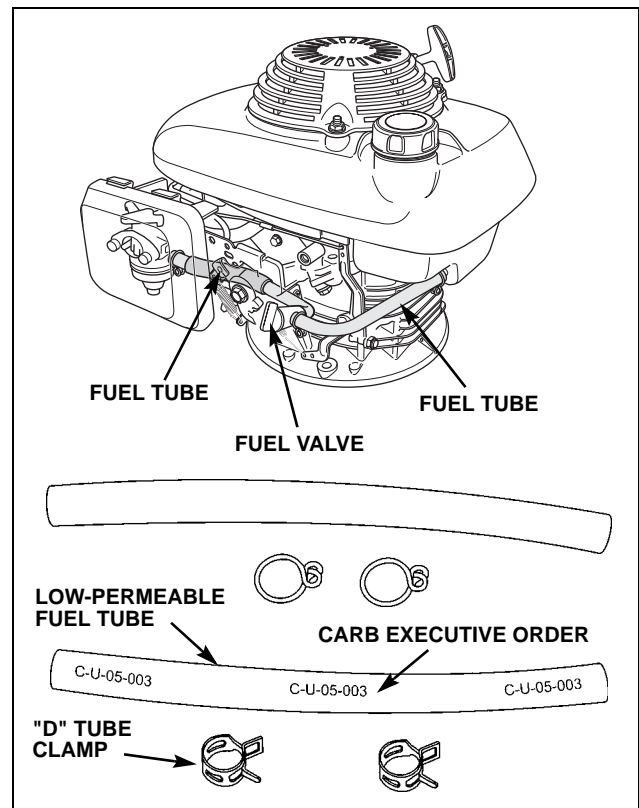

## 14.COMBUSTION CHAMBER CLEANING

1. Prepare a cylinder of thick paper or equivalent material, with a diameter large enough to fit against the inner wall of the cylinder, and insert it into the cylinder for protection.
2. Attach the cleaning brush (commercially available) to an electric drill motor and clean the combustion chamber.

### NOTICE

- *Be sure to insert thick paper into the cylinder to protect the inner wall of the cylinder during cleaning of the combustion chamber.*
- *Do not press the cleaning brush with force against the combustion chamber.*

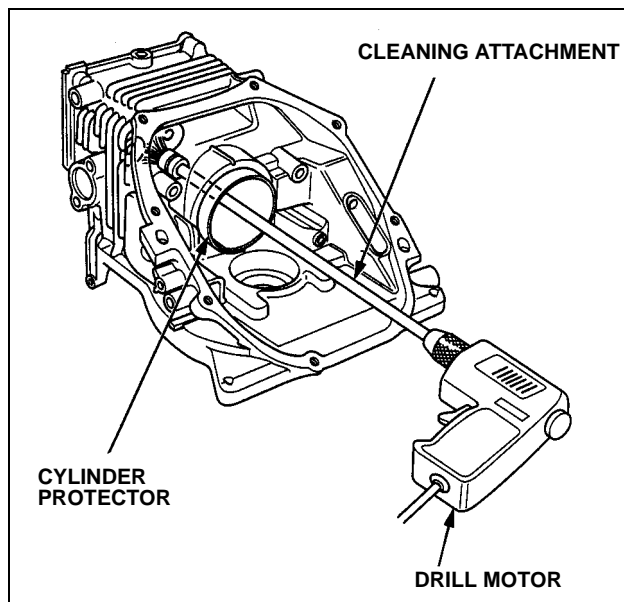

## MAINTENANCE

---

# 4. MUFFLER

1. MUFFLER..... 4-1

## 1. MUFFLER

### REMOVAL/INSTALLATION

#### ⚠ CAUTION

The engine and muffler become very hot during operation, and they remain hot for a while after operation. Be sure that the engine is cold before muffler removal/installation.

#### • ALL TYPES (EXCEPT GCV190N5AP)

**SPARK ARRESTER** (optional part)

**INSTALLATION:**

Install after removing the carbon from the screen with a wire brush.

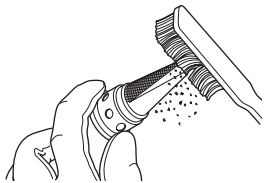

**SPARK ARRESTER IDENTIFICATION PLATE** (optional part)

**4 x 6 mm SELF-TAPPING SCREW** (optional part)

**6 x 12 mm SCREW, (3)**

**MUFFLER PROTECTOR**

**6 x 79 mm FLANGE BOLT (2)**

12 N•m (9 ft-lb)

**MUFFLER GASKET** (optional part)

Install a gasket anytime the muffler has been removed.

**MUFFLER**

**INSTALLATION:**

- Use a plastic hammer to loosen carbon deposits from the muffler, and then remove carbon deposits from muffler.
- Do not tap on the muffler seal flange to avoid damaging this part. If the seal flange is dented or damaged, replace the muffler.
- Check the cylinder exhaust port for damage, and install muffler.

**MUFFLER SEAL FLANGE**

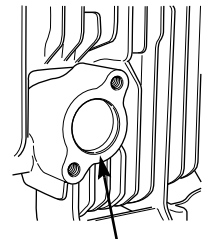
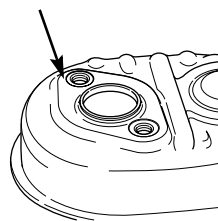

**EXHAUST PORT**



# MUFFLER

## • GCV190N5AP TYPES

1. Remove the three 6 x 12 mm flange bolts and the muffler protector.
2. Remove the two 6 x 79 mm flange bolts and the muffler.
3. Install in the reverse order of removal.

### SPARK ARRESTER [OPTIONAL PART]

#### INSTALLATION:

Install after removing the carbon from the screen with a wire brush.

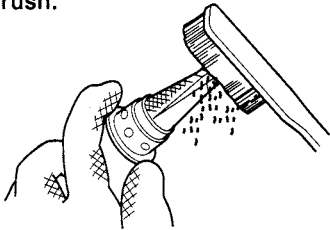

4 x 6 mm SELF-TAPPING SCREW  
(optional part)

6 x 12 (3)

MUFFLER  
PROTECTOR

MUFFLER GASKET

Replace when reinstalling the muffler. Install the muffler gasket as shown.

ARRESTER  
NUMBER PLATE  
[OPTIONAL PART]

6 x 79 (2)

12 N•m (1.2 kgf•m,  
9 lbf•ft)

### MUFFLER

#### INSTALLATION:

- After removing any carbon deposits from the muffler, install using a plastic hammer.
- Do not tap on the muffler seal flange or damage this part. If the seal flange is dented or damaged, replace the muffler.
- Check the cylinder barrel exhaust port for damage.

MUFFLER SEAL  
FLANGE

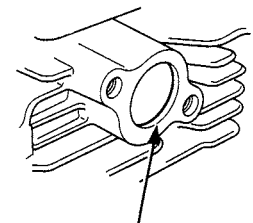
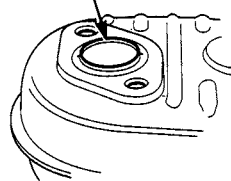

EXHAUST PORT

# 5. RECOIL STARTER

1. RECOIL STARTER ..... 5-1

## 1. RECOIL STARTER

### a. REMOVAL/INSTALLATION

- If the starter rope is frayed or worn out, replace the starter rope ([P. 5-2](#)).
- Do not disassemble the recoil starter assembly.

**6 mm FLANGE NUT (3)**

8.3 N•m (6.1 ft-lb)

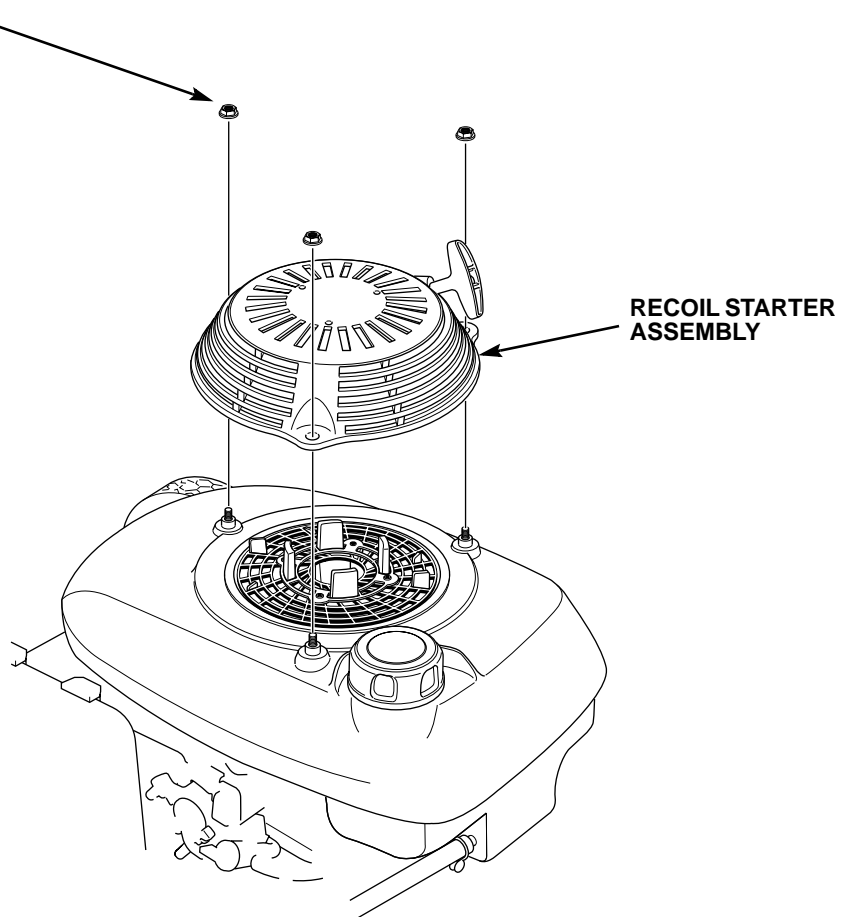

# RECOIL STARTER

## b. STARTER ROPE REPLACEMENT

1. Pull starter grip until the starter rope is pulled out fully.

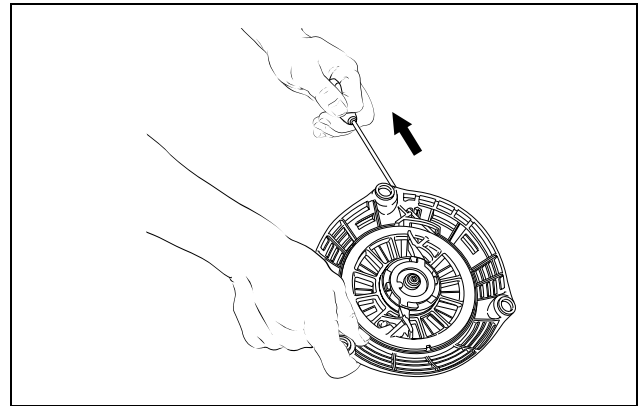

2. To prevent the starter reel from rewinding, hold the starter reel and starter case with a band or equivalent material as shown.

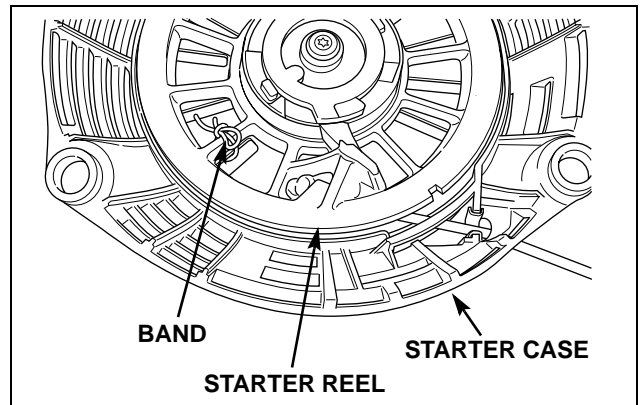

3. Untie the knots of the starter rope at the starter grip side and the starter reel side, and remove the starter rope.

4. Pass the new starter rope through the starter grip and make a knot at the end of the rope.

5. Pass the other end of the starter rope through the rope hole in the starter case and through the rope hole in the starter reel, and make a slip knot at the end of the rope.

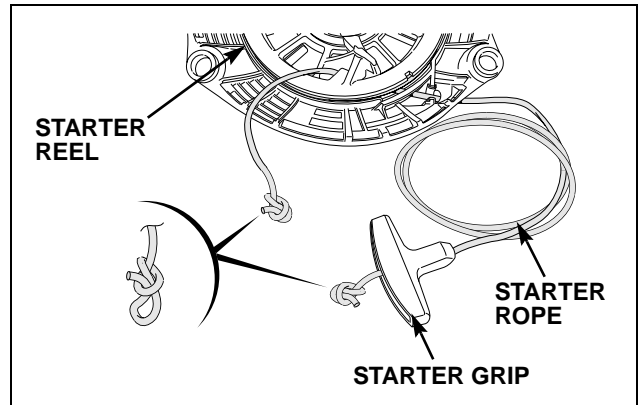

6. Remove the band holding the starter reel and carefully allow the starter reel to rewind.

7. Check the operation of the ratchets by pulling the starter rope several times.

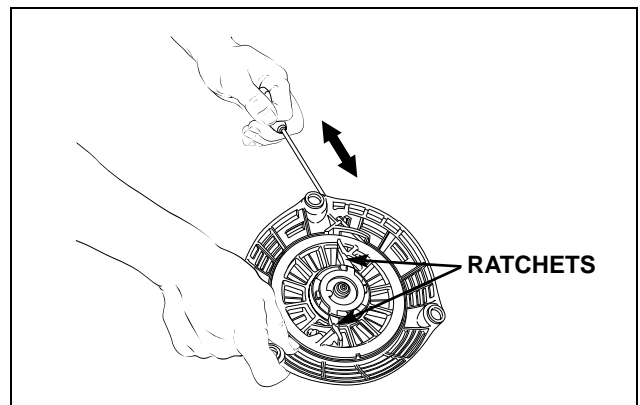

## c. STARTER ROPE BROKEN OR REEL UNWOUND

1. Turn the starter reel in the direction of the arrow six turns. Align the rope hole in the starter case with the rope hole in the starter reel.
2. Pass the starter rope through the starter grip and make a knot at the end of the rope.
3. Pass the other end of the starter rope through the rope hole in the starter case and through the rope hole in the starter reel, and make a slip knot at the end of the rope.
4. Remove the band holding the starter reel and carefully allow the starter reel to rewind.
5. Check the operation of the ratchets by pulling the starter rope several times.

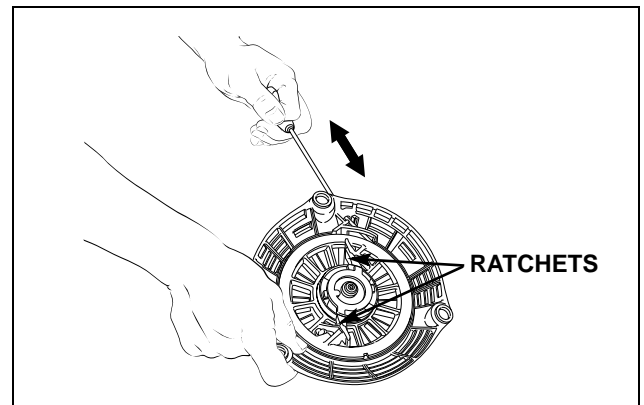
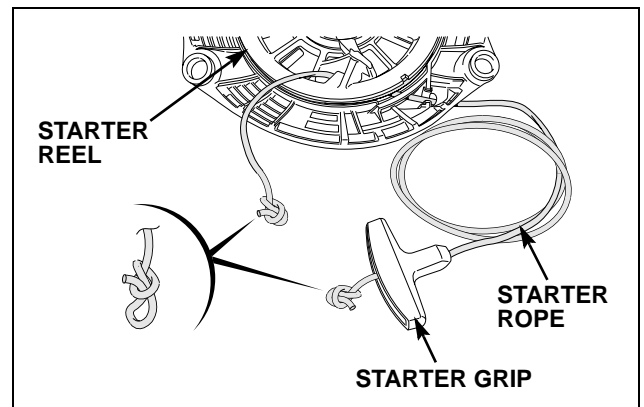
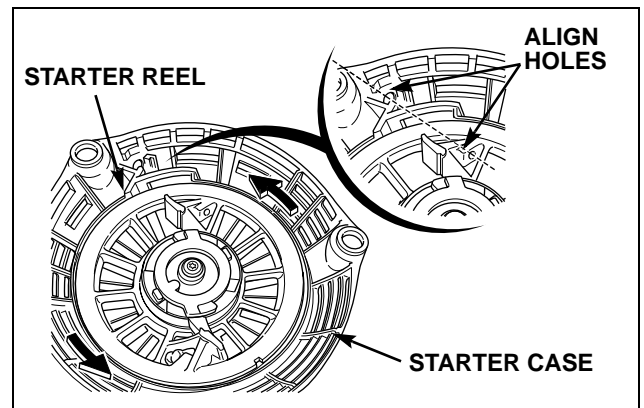

## RECOIL STARTER

---

# 6. FUEL SYSTEM

1. AIR CLEANER/CARBURETOR . . . . . 6-1	3. FAN COVER/FUEL TANK . . . . . 6-21
2. CONTROL BASE/GOVERNOR ARM . . . 6-15	4. FUEL TUBE . . . . . 6-24

## 1. AIR CLEANER/CARBURETOR

### a. REMOVAL/INSTALLATION

Before removal, completely drain the carburetor ([P. 3-20](#)).

#### ⚠WARNING

Gasoline is highly flammable and explosive.  
You can be burned or seriously injured when handling fuel.

- Keep heat, sparks, and flame away.
- Handle fuel only outdoors.
- Wipe up spills immediately.

### REMOVAL

1. Turn the fuel valve to the OFF position.
2. Remove the air cleaner cover and air filter.  
*GSV190:* Remove the foam element and the grid ([P. 3-7](#)).
3. Remove the 6 x 14 mm flange bolt.
4. Remove one 6 x 86 mm flange bolt securing the air cleaner case, and temporarily replace it with a 6 x 83 mm stud. Install and hand-tighten the stud.
5. While pushing the air cleaner case toward the engine, remove the other 6 x 83 mm flange bolt, and temporarily install another 6 x 83 mm stud.

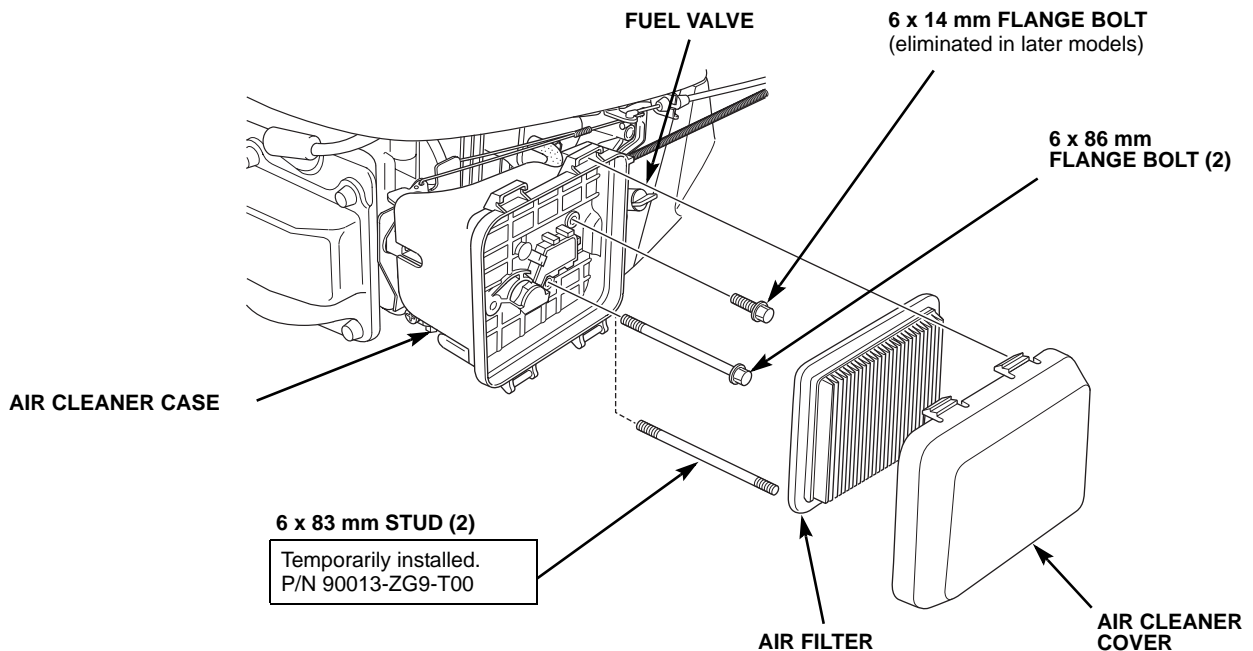

## FUEL SYSTEM

- Pull the breather tube from the engine, and then remove the air cleaner case from the studs.

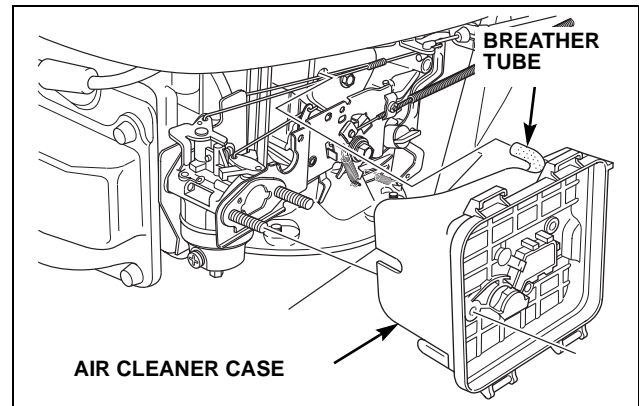

- Remove the 6 x 45 mm flange bolt, and slide the throttle control base and carburetor off the studs.

Certain types may have the carburetor spacer replacing the control base and the 6 x 45 mm flange bolt.

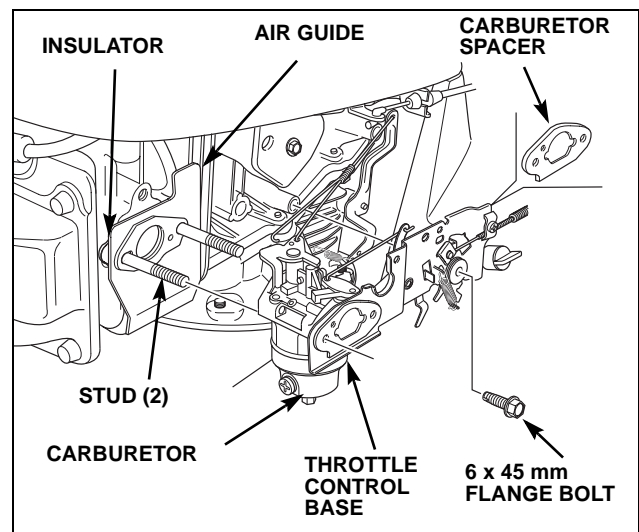

- Remove the throttle return spring from the carburetor throttle lever.
- Rotate the carburetor in the direction shown, and remove the governor rod and choke rod (manual choke types) from the carburetor.

The insulator, air guide, and gaskets do not need to be removed unless the gaskets are damaged and need to be replaced.

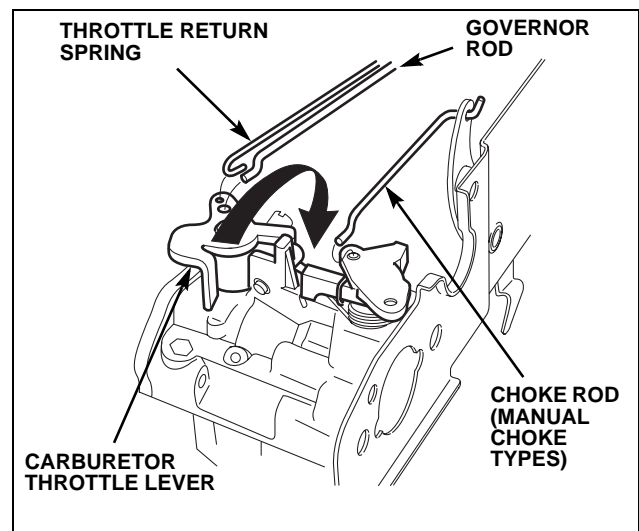

**INSTALLATION**

• **Manual Throttle Control (Control Cable Types)**

**NOTICE**

*If these parts are left out, dirt will enter the intake system, damaging the internal engine parts.*

- Inspect the carburetor gaskets, the air guide gaskets and insulator gaskets. Replace if necessary.
- Install the choke rod, governor rod and return spring.
- Install the crankcase breather hose with the painted mark even with the crankcase breather chamber cover.
- Install the air cleaner case over the studs. Replace one stud with the original 6 x 86 mm flange bolt and hand tighten. Replace the other stud with the 6 x 86 mm flange bolt.
- Tighten both 6 x 86 mm flange bolts to the specified torque.

**TORQUE: 9.8 N•m (7.2 ft-lb)**

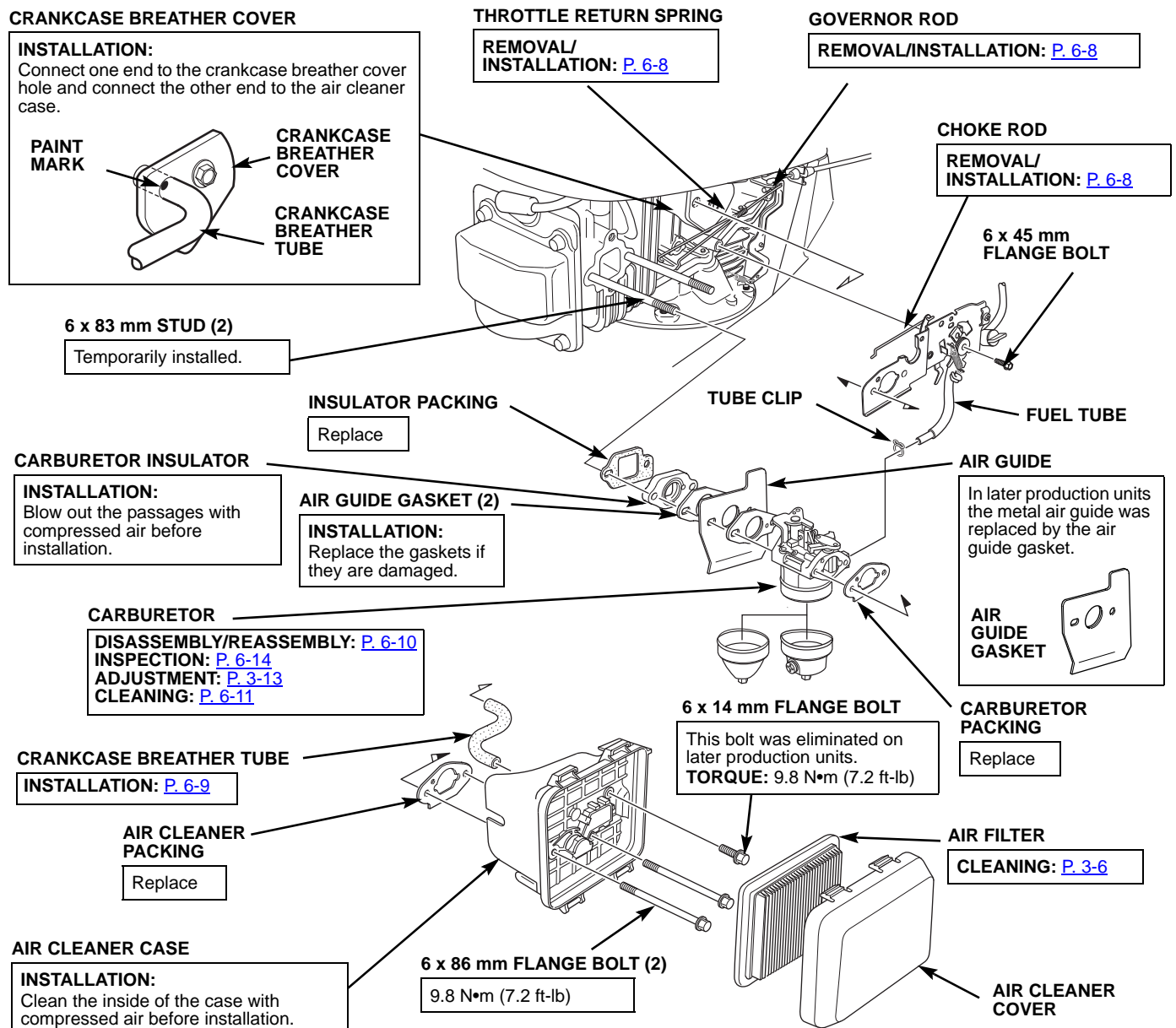



# FUEL SYSTEM

## • ARCS Types (Fixed Throttle/Flywheel Brake)

### GOVERNOR ROD/THROTTLE RETURN SPRING

**REMOVAL:**  
Remove the throttle return spring, and then rotate the carburetor in the direction shown and remove the governor rod from the carburetor.

**THROTTLE RETURN SPRING**

INSTALLATION: [P. 6-8](#)

**GOVERNOR ROD**

INSTALLATION: [P. 6-8](#)

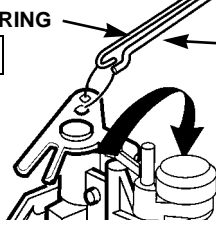

**FUEL VALVE ASSEMBLY**

DISASSEMBLY: [P. 6-18](#)

**D" STYLE HOSE CLAMP (4)**

"D" style hose clamps are used with low-permeable fuel line.

**GOVERNOR SPRING**

INSTALLATION: [P. 6-15](#)

6 x 12 mm  
FLANGE BOLT

6 x 28 mm  
FLANGE BOLT

**CRANKCASE BREATHER TUBE**

INSTALLATION: [P. 6-9](#)

**INSULATOR GASKET**

Replace

**CARBURETOR  
SPACER**

**AIR CLEANER  
CASE**

**CARBURETOR  
INSULATOR**

**PAPER ELEMENT**  
CLEANING: [P. 3-6](#)

**AIR GUIDE GASKET**

Replace

**CARBURETOR**

DISASSEMBLY/REASSEMBLY: [P. 6-10](#)  
INSPECTION: [P. 6-14](#)  
ADJUSTMENT: [P. 3-13](#)  
CLEANING: [P. 6-11](#)

**AIR CLEANER GASKET (2)**

Replace

6 x 83 mm STUD (2)

**PART NUMBER: 90013-ZG9-T00**  
Temporarily install to make carburetor installation easier.

6 x 83 mm FLANGE BOLT (2)

9.8 N•m (7.2 ft-lb)

**AIR CLEANER  
COVER**

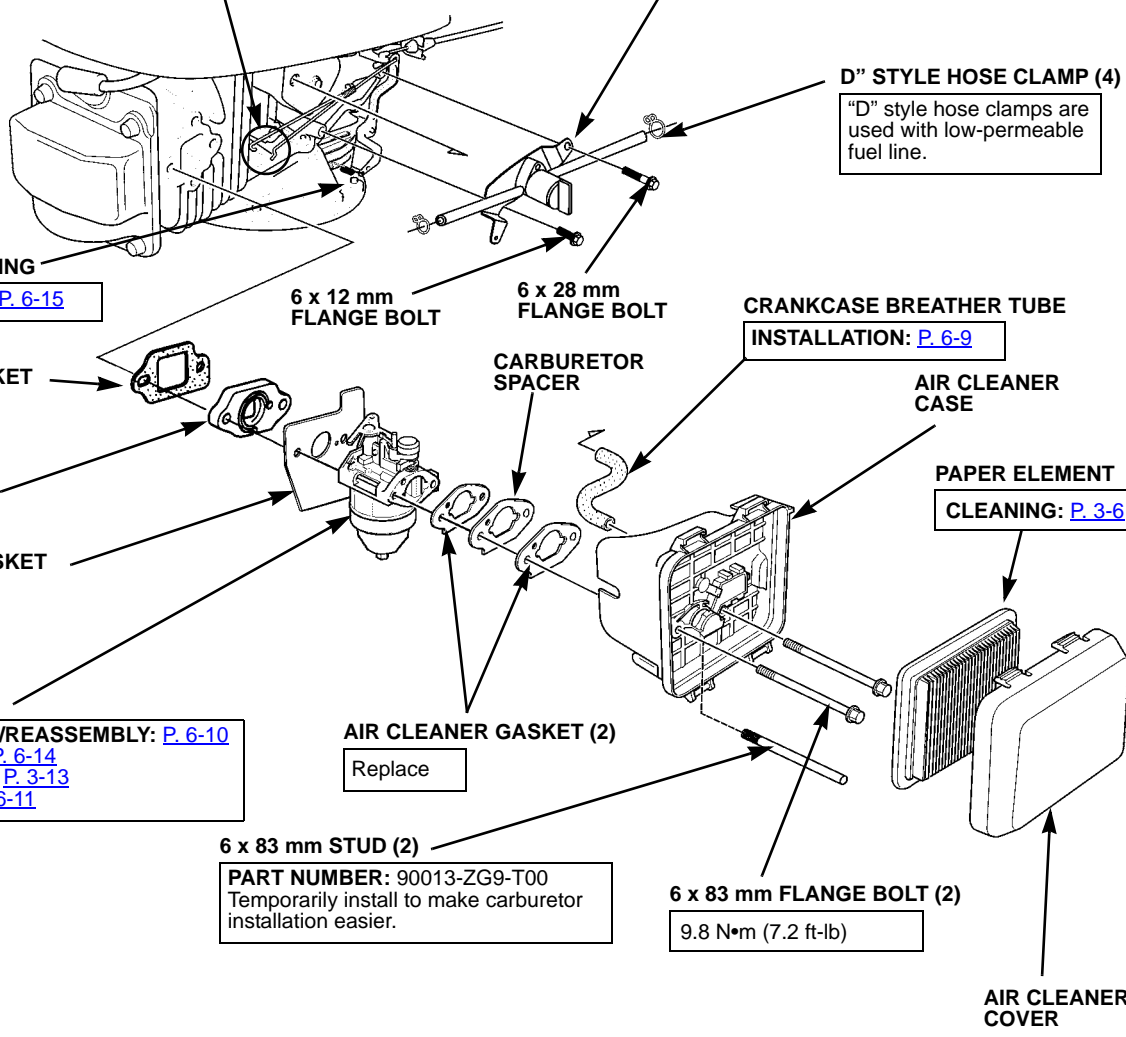

• ACS (Auto-Choke System)  
With Control Base Type

**GOVERNOR ROD/THROTTLE RETURN SPRING**

**REMOVAL:**  
Remove the throttle return spring, and then rotate the carburetor in the direction shown and remove the governor rod from the carburetor.

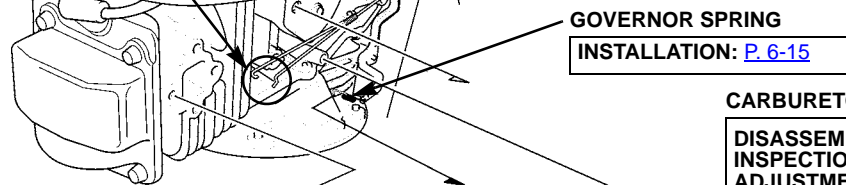
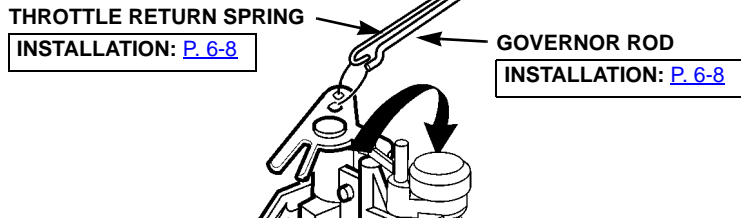

**CARBURETOR**  
DISASSEMBLY/REASSEMBLY: [P. 6-10](#)  
INSPECTION: [P. 6-14](#)  
ADJUSTMENT: [P. 3-13](#)  
CLEANING: [P. 6-11](#)

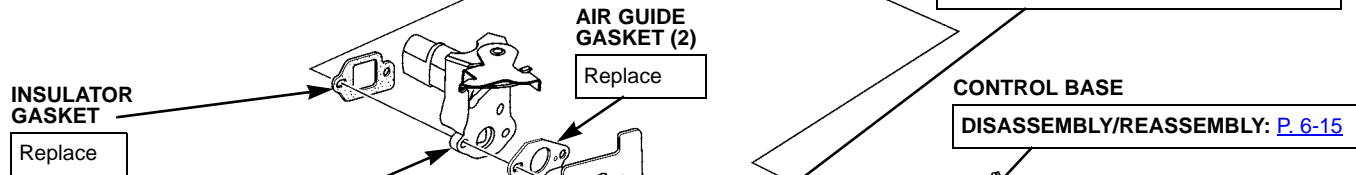

**CHOKE CONTROL ASSEMBLY**

- Be sure the engine and the auto-choke control assembly are cold before installing.
- Apply a 3 ~ 5 mm thick bead of Hondabond HT to the bottom surface of the heat sink as shown.

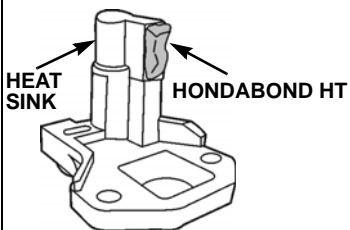

TRUBLESHOOTING: [P. 2-34](#)  
INSTALLATION: [P. 6-9](#)

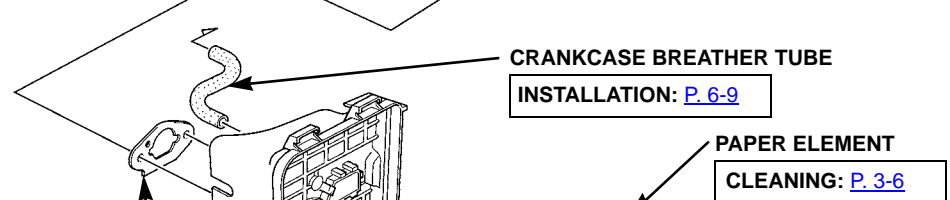
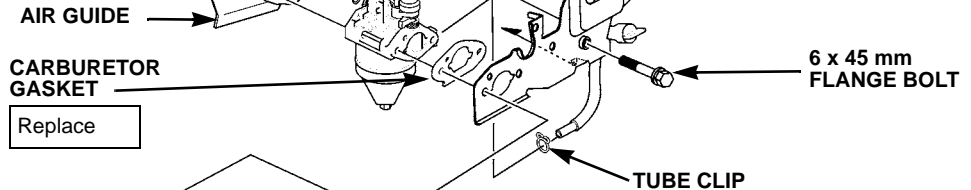

**AIR CLEANER GASKET**

**6 x 83 mm FLANGE BOLT (2)**  
9.8 N•m (7.2 ft-lb)

**AIR CLEANER COVER**

**6 x 83 mm STUD (2)**  
**PART NUMBER: 90013-ZG9-T00**  
Temporarily install to make carburetor installation easier.

# FUEL SYSTEM

## Without Control Base Type

### GOVERNOR ROD/THROTTLE RETURN SPRING

**REMOVAL:**  
Remove the throttle return spring, and then rotate the carburetor in the direction shown and remove the governor rod from the carburetor.

**THROTTLE RETURN SPRING**

INSTALLATION: [P. 6-8](#)

**GOVERNOR ROD**

INSTALLATION: [P. 6-8](#)

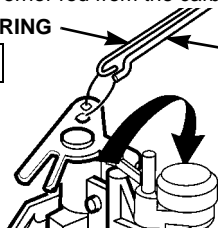

**GOVERNOR SPRING**

INSTALLATION: [P. 6-8](#)

**FUEL VALVE ASSEMBLY**

DISASSEMBLY: [P. 6-18](#)

**THERMOWAX ASSEMBLY**

ID MARK  
GCV160 = Z1  
GCV190 = ZY

**INSULATOR GASKET**

Replace

**CHOKE CONTROL ASSEMBLY**  
(without heat sink)

TROUBLESHOOTING: [P. 2-34](#)  
INSTALLATION: [P. 6-8](#)

**AIR GUIDE GASKET**

Replace

**CARBURETOR GASKET**

Replace

**SPACER**

**AIR CLEANER GASKET**

Replace

**CARBURETOR**

DISASSEMBLY/REASSEMBLY: [P. 6-10](#)  
INSPECTION: [P. 6-14](#)  
ADJUSTMENT: [P. 3-13](#)  
CLEANING: [P. 6-11](#)

**CARBURETOR**

DISASSEMBLY/REASSEMBLY: [P. 6-10](#)  
INSPECTION: [P. 6-14](#)

**CRANKCASE BREATHER TUBE**

INSTALLATION: [P. 6-9](#)

**AIR CLEANER CASE**

**PAPER ELEMENT**

CLEANING: [P. 3-6](#)

**6 x 83 mm STUD (2)**

**PART NUMBER: 90013-ZG9-T00**  
Temporarily install to make carburetor installation easier.

**6 x 86 mm FLANGE BOLT (2)**

10 N•m (7 ft•lb)

**AIR CLEANER COVER**

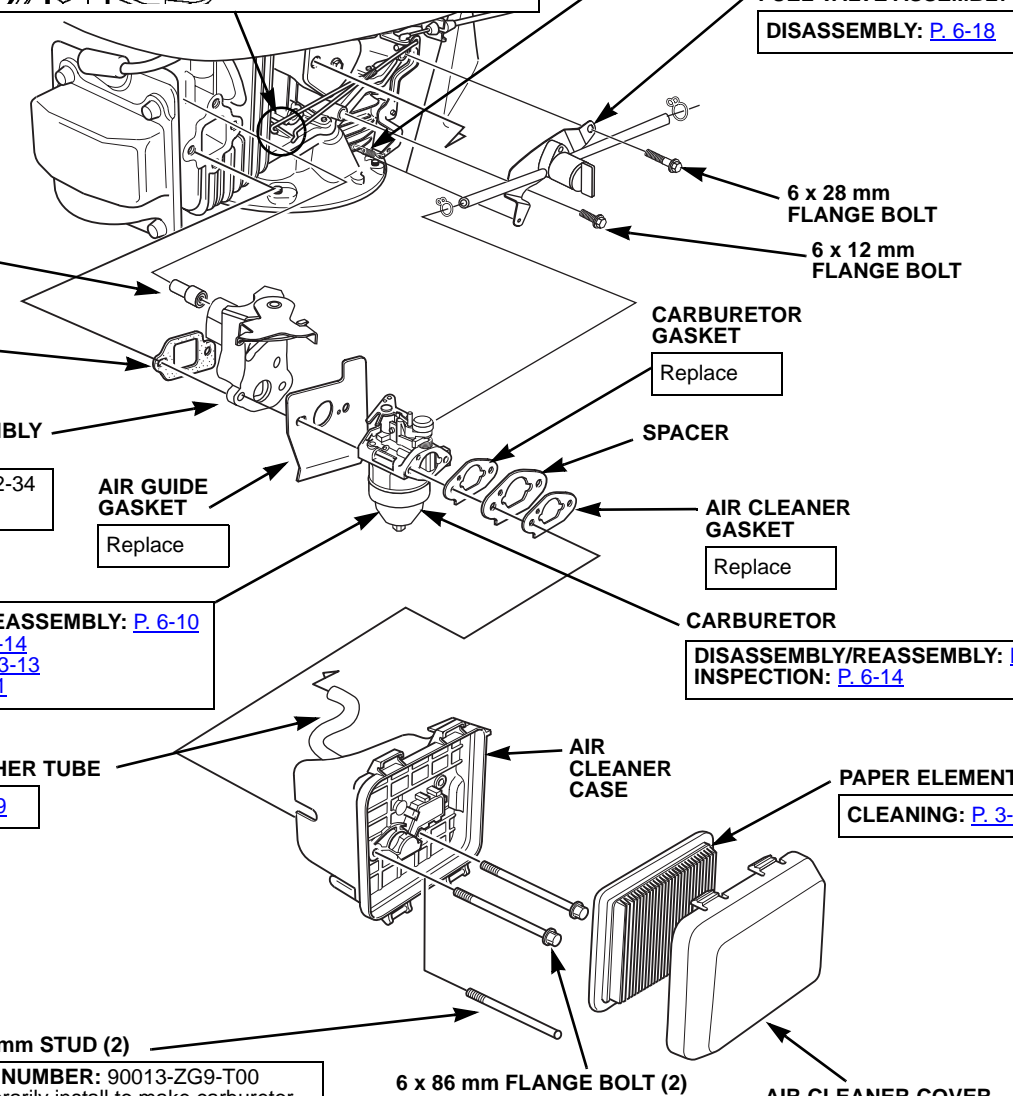

## • GCV190N5AV Auto Throttle Type

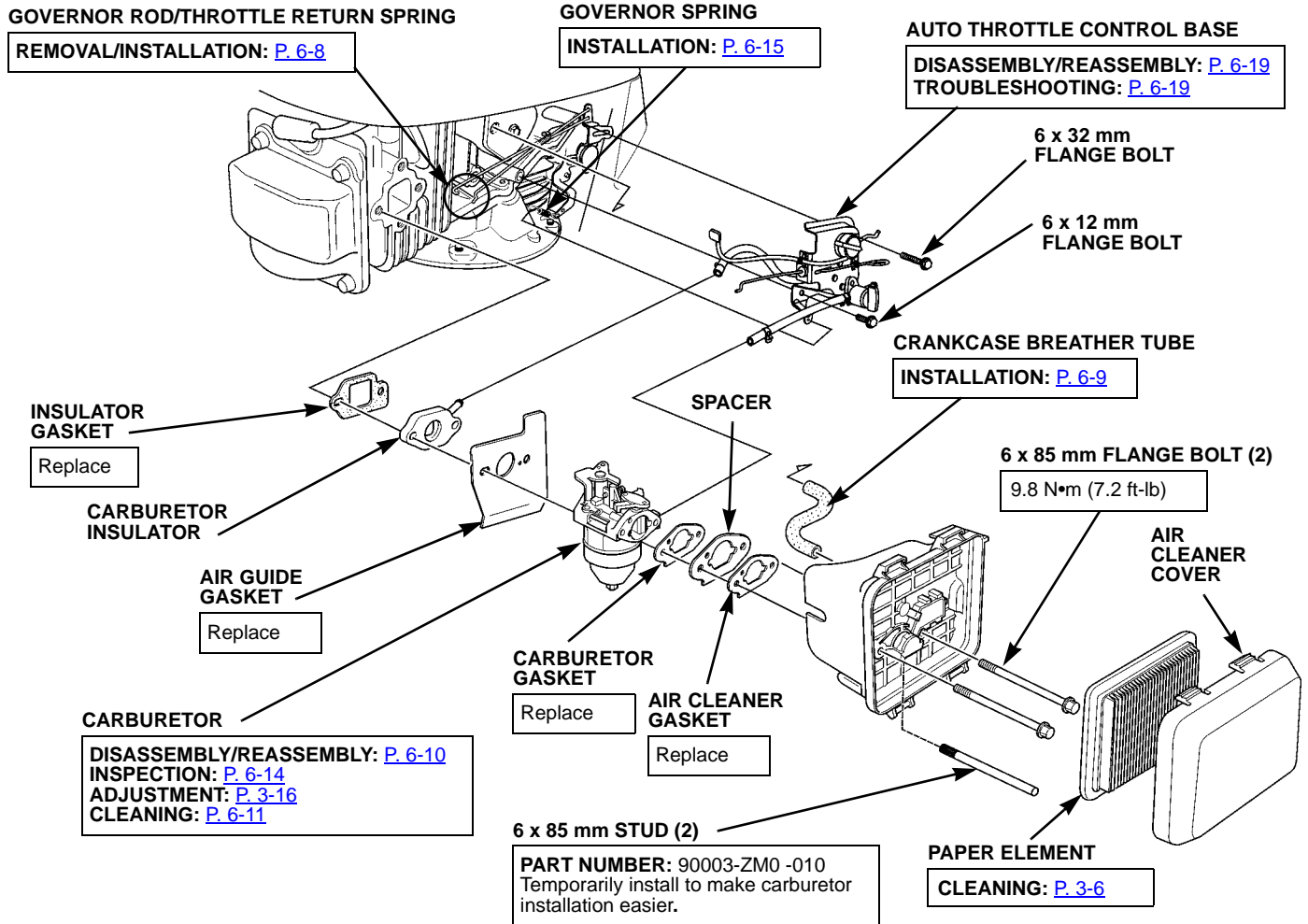

## FUEL SYSTEM

### GOVERNOR ROD/THROTTLE RETURN SPRING/CHOKE ROD

#### Removal

1. Unhook the throttle return spring.
2. Remove the two 6 x 86 mm flange bolts and the 6 x 14 mm flange bolt from the air cleaner case ([P. 6-1](#)).
3. Remove the air cleaner base, air cleaner packing, carburetor packing, air guide, carburetor insulator, and insulator packing ([P. 6-1](#)).
4. Unhook the choke rod (except ACS and ARCS types) and governor rod from the carburetor.

#### Installation

1. Set the choke rod (except ACS and ARCS types) on the carburetor choke valve.
2. Hook the governor rod in the large hole in the carburetor throttle valve.  
Hook the throttle return spring in the smaller hole in the carburetor throttle valve.
3. Install the insulator packing, carburetor insulator, air guide, carburetor, carburetor packing, air cleaner packing, and air cleaner case ([P. 6-1](#)).

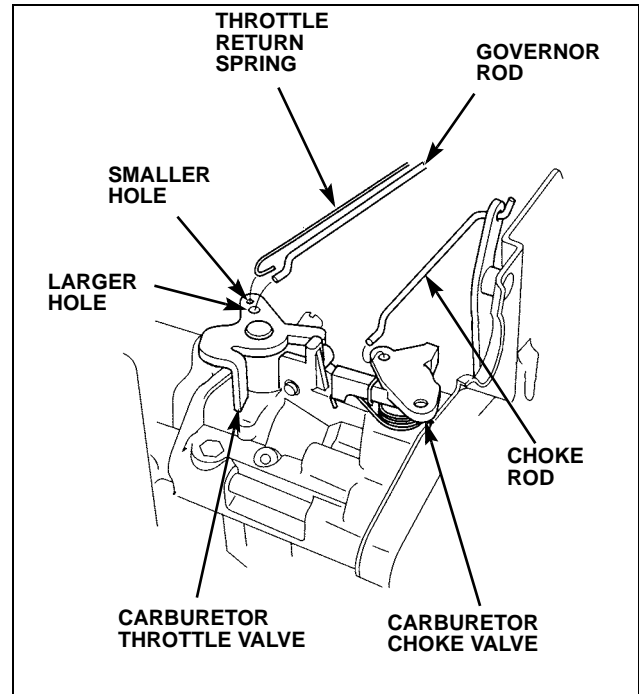

### GCV190N5AV AUTO THROTTLE

#### Removal

1. Turn the fuel valve OFF.
2. Unhook the throttle return spring.
3. Remove the two 6 x 85 mm flange bolts from the air cleaner case ([P. 6-7](#)).
4. Remove the air cleaner base, air cleaner packing, carburetor packing, air guide, carburetor insulator, and insulator packing ([P. 6-7](#)).
5. Remove the fuel tube from the carburetor.
6. Rotate the carburetor in the direction shown and unhook the choke rod and governor rod from the carburetor.

#### Installation

1. Set the choke rod on the carburetor choke valve forward hole.
2. Hook the governor rod in the large hole in the carburetor throttle valve.

Hook the throttle return spring in the smaller hole in the carburetor throttle valve.

3. Reconnect the fuel tube.

4. Install the insulator packing, carburetor insulator, air guide, carburetor, carburetor packing, air cleaner packing, and air cleaner case ([P. 6-7](#)).

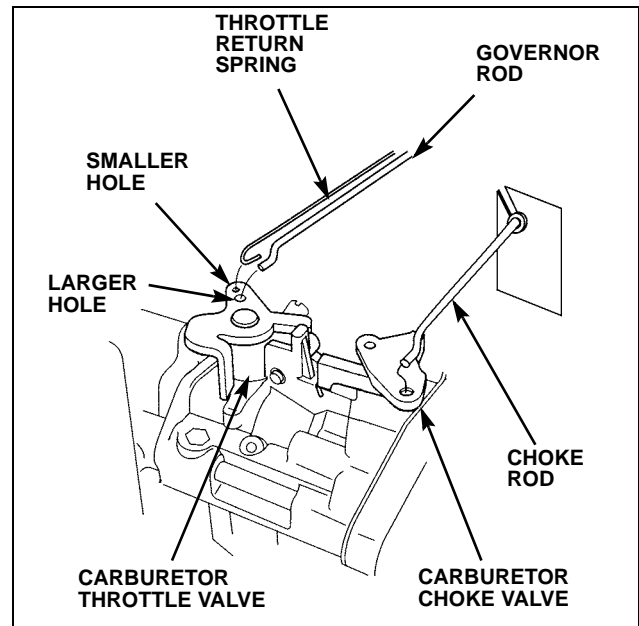

## BREATHER TUBE

### Installation

Connect the end with the white mark to the breather cover hole as shown. Connect the other end to the air cleaner case.

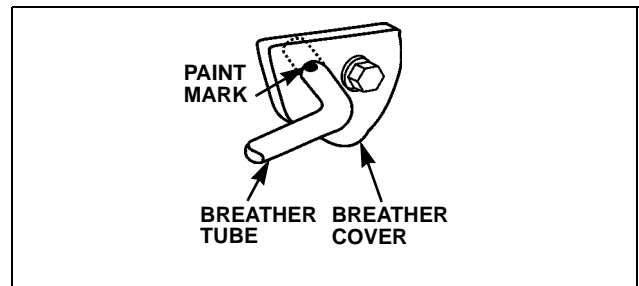

## CHOKE CONTROL ASSEMBLY (ACS TYPES)

### Installation

1. Install the choke assembly when the temperature is less than 40°C (104°F).
2. Verify that the carburetor choke lever is in the fully closed position.
3. Install the carburetor and choke assembly ([P. 6-5](#) or [P. 6-6](#)).
4. After installation, verify that there is clearance between choke lever A and the carburetor choke lever.

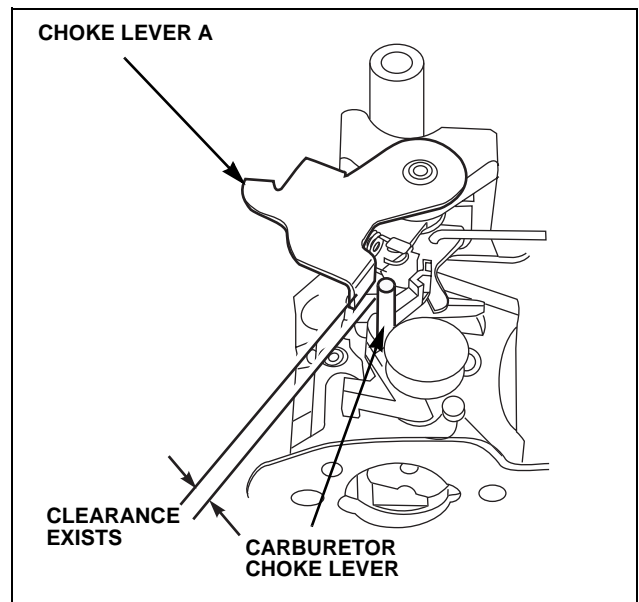

# FUEL SYSTEM

## b. DISASSEMBLY/REASSEMBLY

- Clean the outside of the carburetor before disassembly.
- The limiter cap is cemented on the pilot screw and should not be removed unless the carburetor is overhauled.

### ⚠WARNING

Gasoline is highly flammable and explosive.  
You can be burned or seriously injured when handling fuel.

- Keep heat, sparks, and flame away.
- Handle fuel only outdoors.
- Wipe up spills immediately.

#### 5 x 6 mm ACCESS SCREW

##### INSPECTION:

Remove access screw to clean the slow speed jet.

##### REASSEMBLY:

Clean thoroughly with compressed air.

PILOT JET  
(nonremovable)

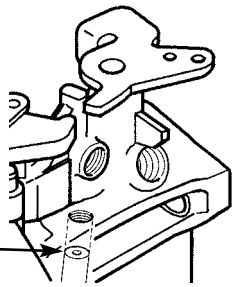

#### PILOT SCREW

##### REPLACEMENT: [P. 6-14](#)

Fixed-throttle models (models that do not idle) do not have a pilot screw, but still have the transition ports.

#### LIMITER CAP

REPLACEMENT: [P. 6-14](#)

#### THROTTLE STOP SCREW

ADJUSTMENT: [P. 3-13](#)

#### CARBURETOR BODY

##### CLEANING: [P. 6-11](#)

##### REASSEMBLY:

Clean internal passages and orifices with compressed air before installation.

#### MAIN NOZZLE

##### REASSEMBLY:

Clean thoroughly with compressed air before installation.



#### MAIN JET

Standard main jet size: [P. 2-5](#)

##### REASSEMBLY:

Clean thoroughly with compressed air before installation.



#### FLOAT VALVE

##### REASSEMBLY:

Check for worn float valve seat and float valve before installation.

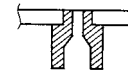

FLOAT VALVE

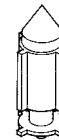

OK



REPLACE

#### FLOAT

##### REASSEMBLY:

Check for smooth movement after installation.

##### INSPECTION: [P. 6-14](#)

#### FLOAT PIN

#### SET GASKET

FLOAT CHAMBER  
(with drain bolt)

FLOAT CHAMBER  
(without drain bolt)

#### SET BOLT

##### REASSEMBLY:

After assembly, check for any signs of fuel leakage.

DRAIN BOLT

SEALING WASHER

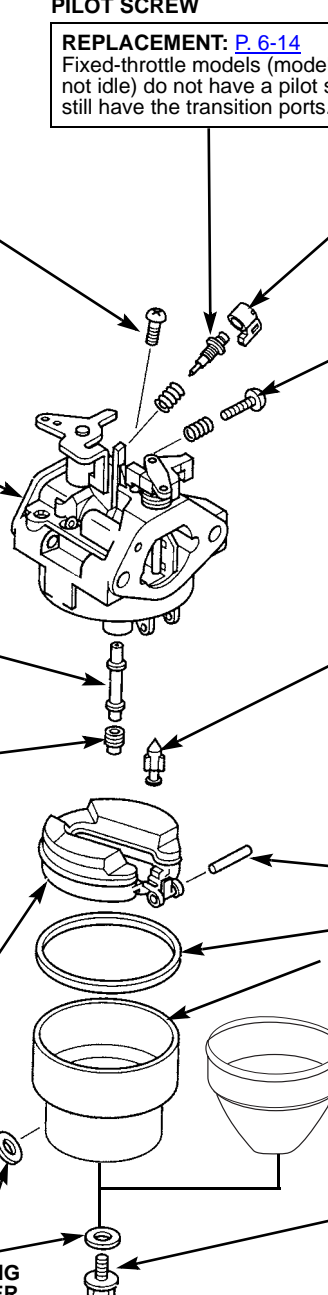

**c. CLEANING**

Use Honda Carburetor Cleaner (P/N 08732-CC000) with its plastic spray nozzle to clean the carburetor ports.

Some commercially-available chemical carburetor cleaners are very caustic. These cleaners may damage plastic parts such as O-rings, floats, choke valves, and float valve seats. Check the container for instructions. If you are in doubt, do not use these products to clean Honda carburetors.

**NOTICE**

*High air pressure may damage the carburetor. Use low pressure settings when cleaning passages.*

1. Completely disassemble the carburetor except for the pilot jet screw (P. 6-10). This cleaning procedure is performed without removing the pilot jet screw.
2. Clean the main nozzle thoroughly using carburetor cleaner, appropriate size jet cleaning tool, and compressed air. Do not use a welding tip cleaning needle.

**NOTICE**

*Using a welding tip cleaning needle or a jet needle that is too large may damage the carburetor. Never force a needle, and never use a needle with a bent or damaged tip.*

Inspect the center and side holes for damage or contamination by holding the main nozzle up to a light to verify they are clean.

3. Clean the main jet by spraying carburetor cleaner through the jet and using the appropriate size jet cleaning tool and compressed air. Do not use a welding tip cleaning needle.

**NOTICE**

*Using a welding tip cleaning needle or a jet needle that is too large may damage the carburetor. Never force a needle, and never use a needle with a bent or damaged tip.*

Carefully inspect the main jet for damage or contamination.

4. Clean the float valve seat using carburetor cleaner and compressed air.

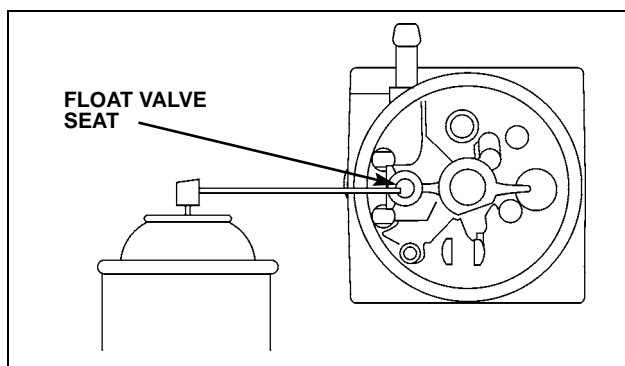
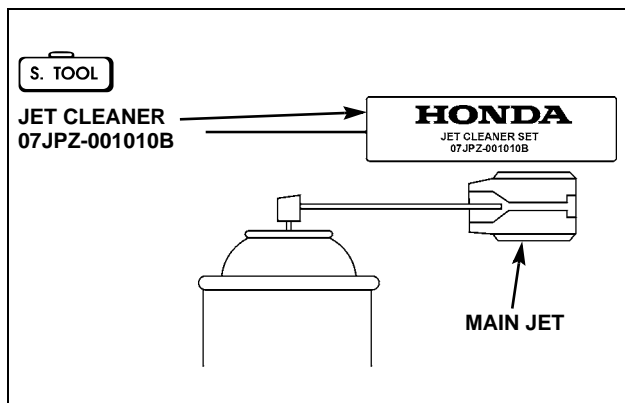
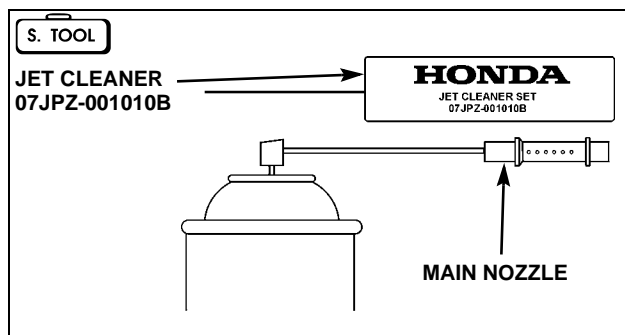



## FUEL SYSTEM

---

5. Clean the main jet and nozzle bore thoroughly using carburetor cleaner and compressed air.

Inspect the inside of the bore for contamination.

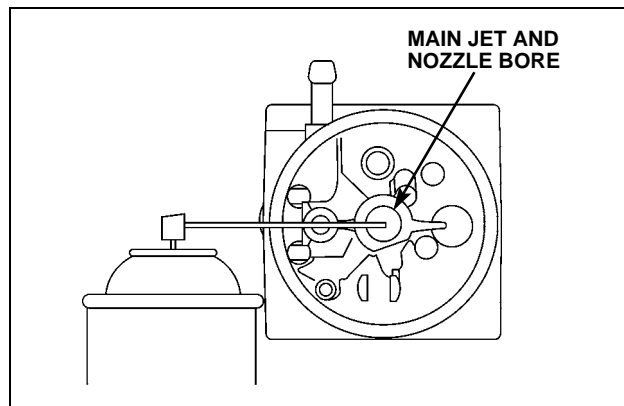

6. Clean the pilot jet thoroughly by using the appropriate size jet cleaning tool, carburetor cleaner, and compressed air.

The passage is small and easily obstructed, so repeat several times.

It is not necessary to remove the pilot screw at this point.

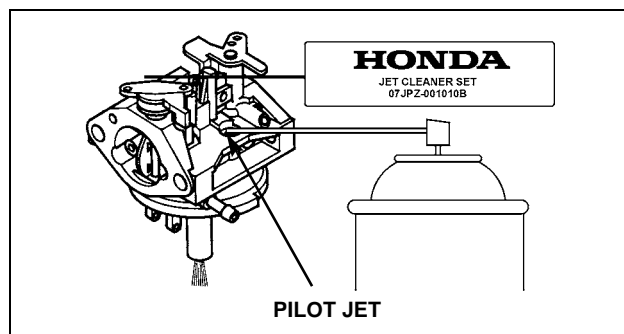

7. Clean the high speed air passage with carburetor cleaner and compressed air.

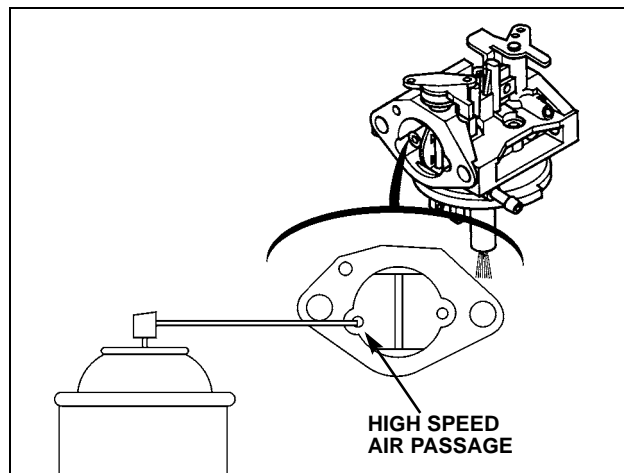

- Clean the float chamber vent hole with carburetor cleaner and compressed air.

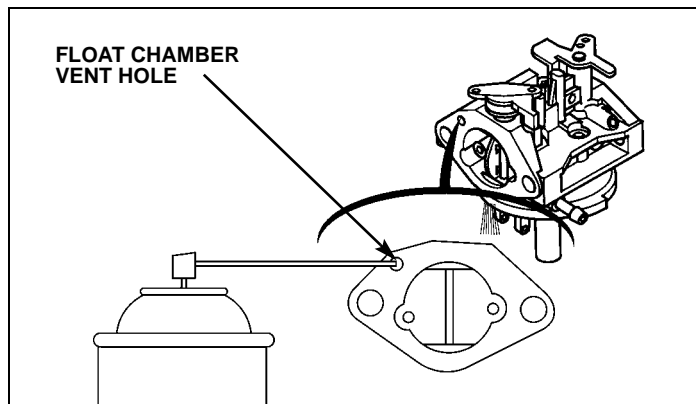

- Reinstall the 5 x 6 mm screw covering the pilot jet.
- Check the slow speed air/pilot screw channels for obstructions.

Spray carburetor cleaner through the slow speed air passage.

From the opposite end, confirm that a steady stream of carburetor cleaner sprays out from around the pilot screw tip and transition ports.

If it does not flow around the pilot screw tip, remove the pilot screw and clean the passage. The pilot screw must be destroyed and replaced if it is removed. It may be more cost-effective to replace the carburetor.

- Reassemble the carburetor.

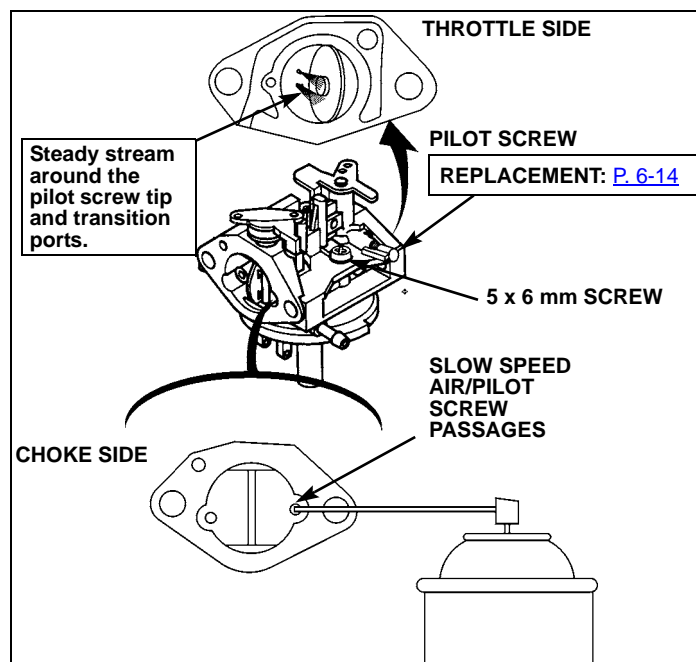

# FUEL SYSTEM

## d. INSPECTION

### • FLOAT LEVEL HEIGHT

Place the carburetor in the position shown, and measure the distance between the float tip and carburetor body when the float just contacts the seat without compressing the valve spring.

#### TOOL:

Float level gauge

07401-0010000

Standard float height	Without drain bolt: 7.2 mm (0.28 in) With drain bolt: 9.2 mm (0.36 in)
-----------------------	---

If the height is out of specification, replace the float and/or the float valve. Recheck the float height.

### • PILOT SCREW AND LIMITER CAP REPLACEMENT

Leave the pilot screw and limiter cap in place during carburetor cleaning. Remove only if necessary for carburetor repair.

Removal of the limiter cap requires breaking the pilot screw. A new pilot screw and limiter cap must be installed.

1. When the limiter cap has been broken off, remove the broken pilot screw.
2. Place the spring on the replacement pilot screw, and install it on the carburetor.
3. Turn the pilot screw in until it is lightly seated, then turn the screw out the required number of turns (see [P. 2-5](#) for pilot screw setting by carburetor ID).

4. Apply Loctite® 638 to the inside of the limiter cap, then install the cap so the stop prevents the pilot screw from being turned counterclockwise.

Be careful to avoid turning the pilot screw while installing the limiter cap. The pilot screw must stay at its required setting.

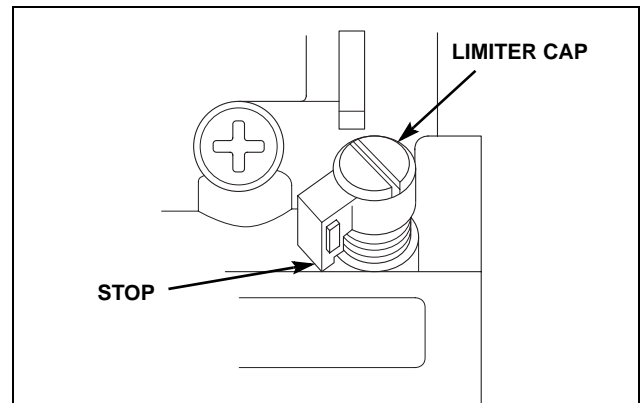
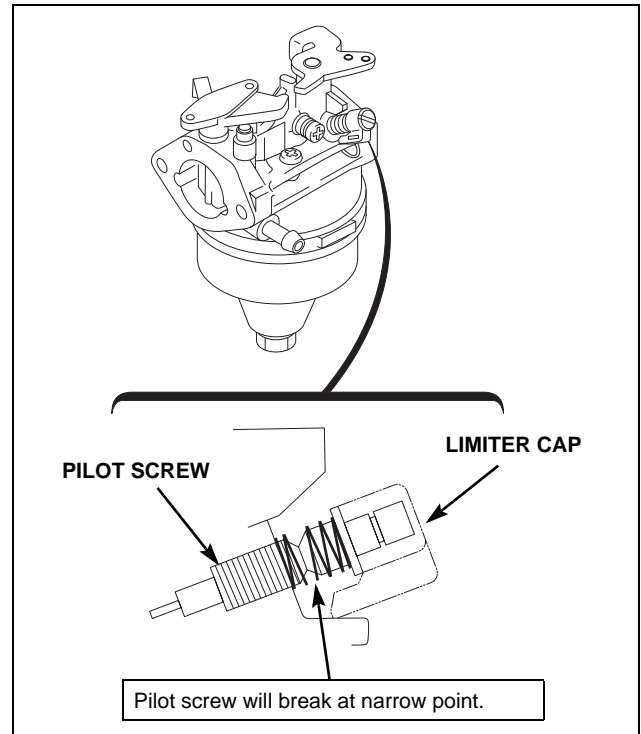
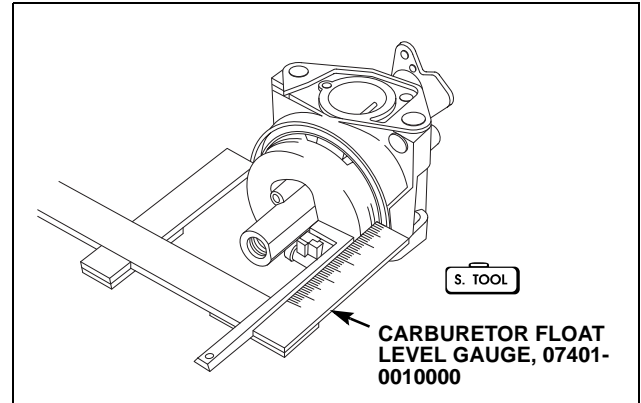

## 2. CONTROL BASE/GOVERNOR ARM

### DISASSEMBLY/REASSEMBLY

Remove the air cleaner and carburetor ([P. 6-1](#)).

- FLYWHEEL BRAKE /SOLID WIRE TYPE

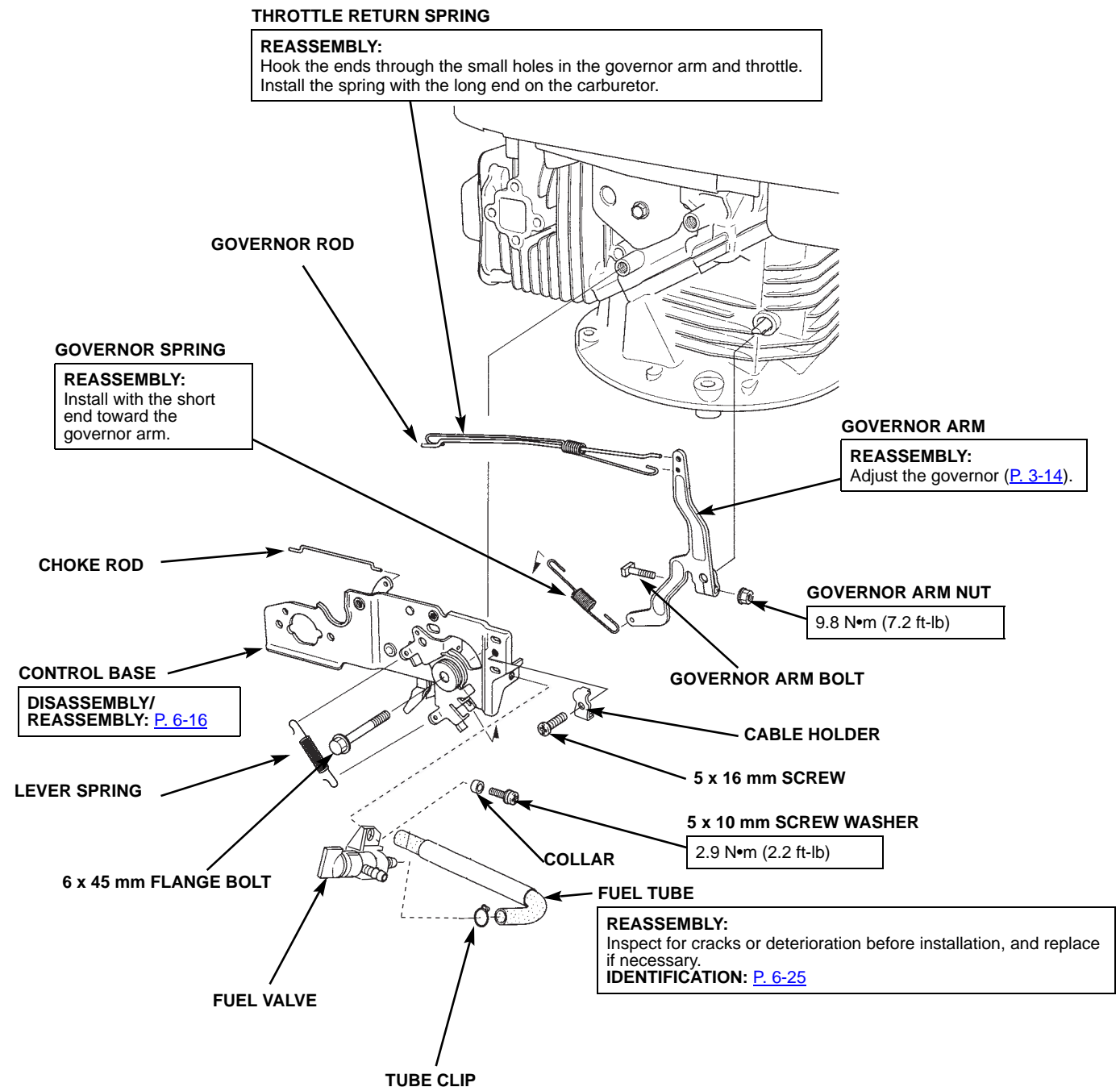

# FUEL SYSTEM

## • Without Flywheel Brake/Solid Wire Cable Wire Type

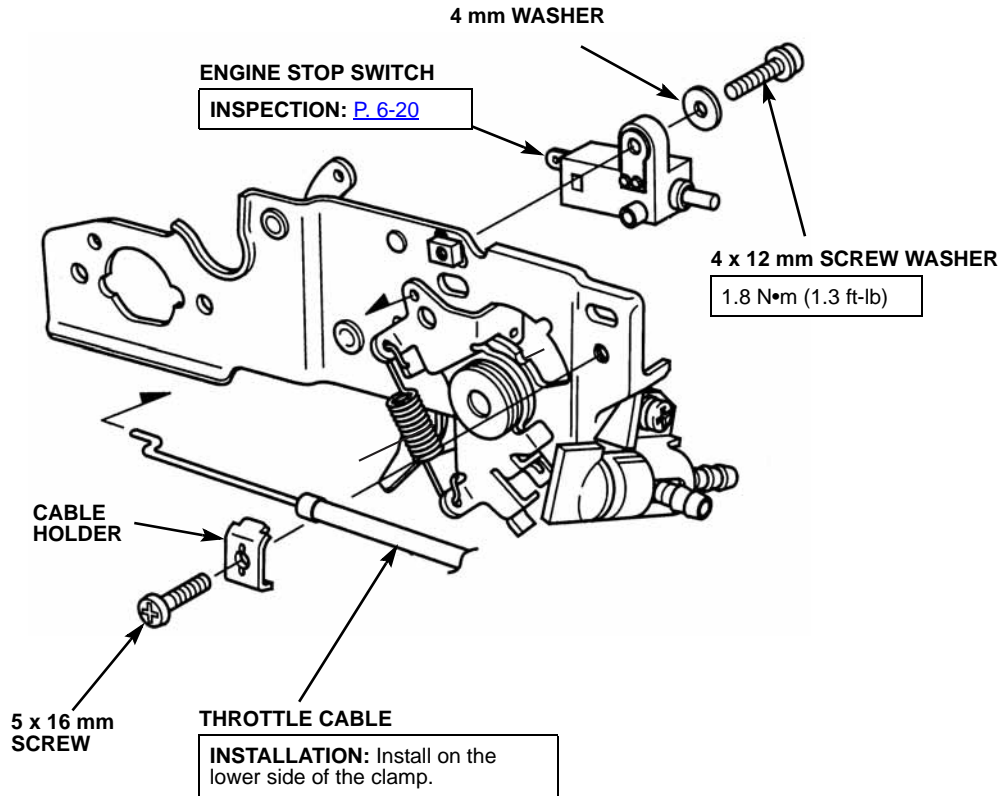

## • Without Engine Stop Switch/Wire Cable Type

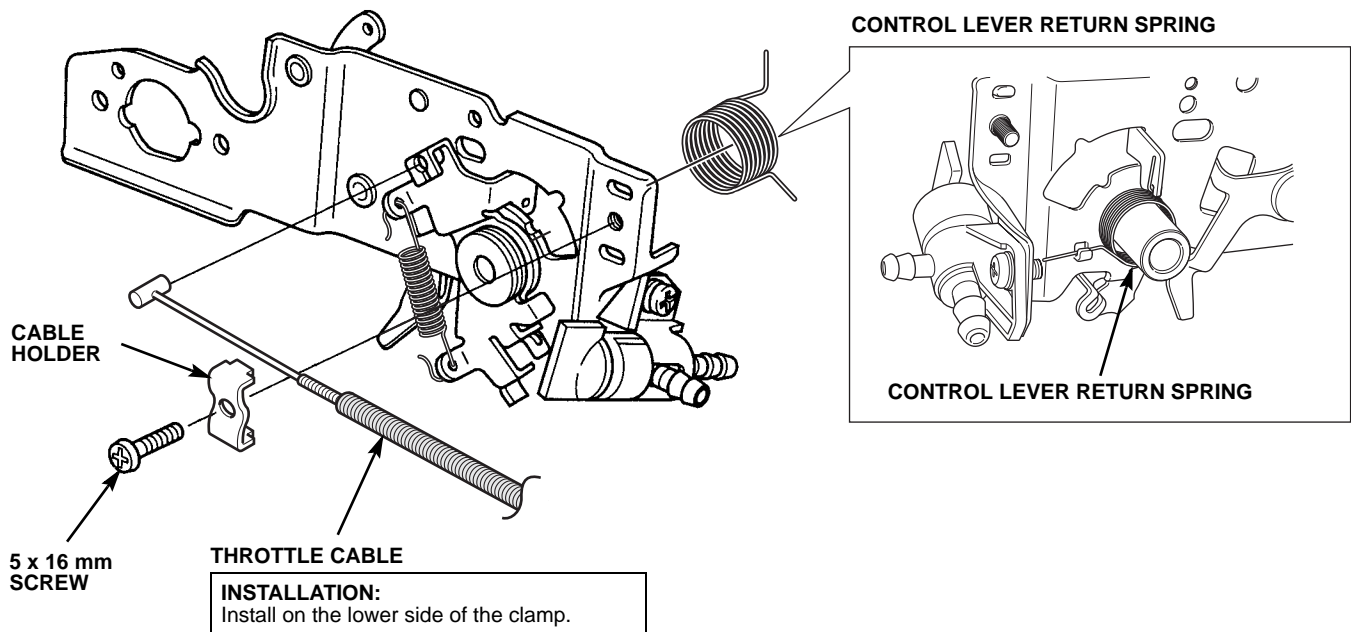

• Fixed Throttle/Manual Choke/Without Flywheel Brake

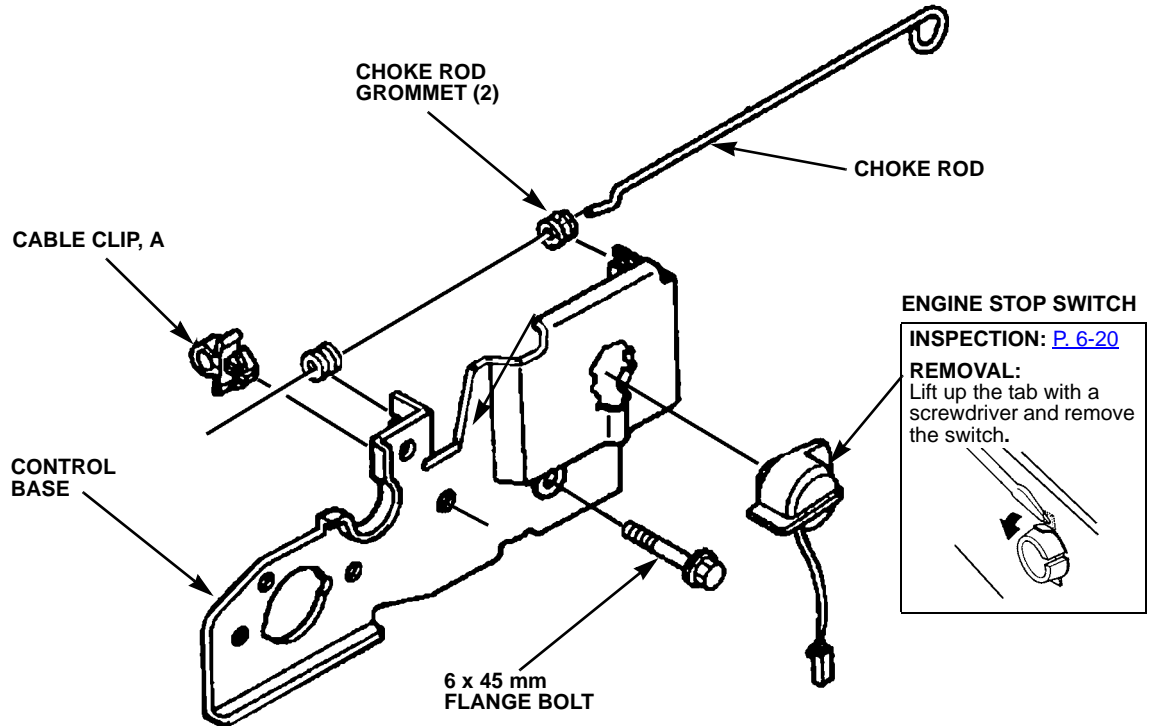

• Manual Throttle/Manual Choke/Without Flywheel Brake

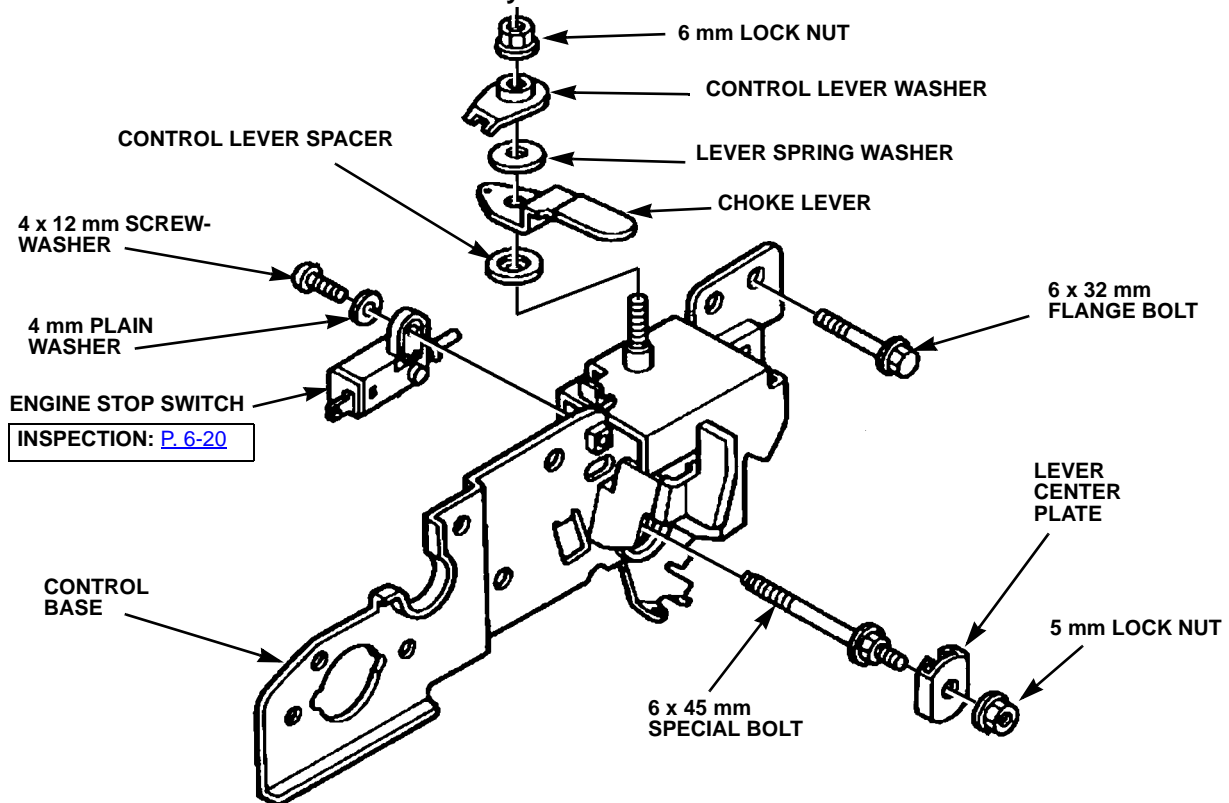

# FUEL SYSTEM

## • Fixed Throttle/Automatic Return Choke System (ARCS) /With Flywheel Brake

### GOVERNOR ARM/THROTTLE RETURN SPRING

#### INSTALLATION:

Install the governor rod through the throttle return spring as shown. Connect each to the governor arm and carburetor throttle arm as shown.

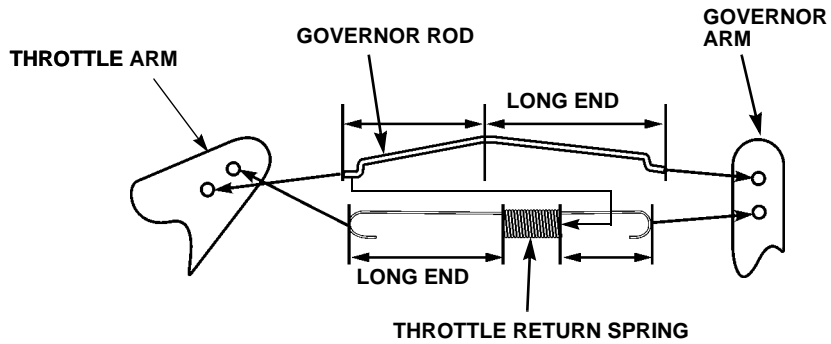

#### 4.5 x 110 mm FUEL TUBE

##### REASSEMBLY:

Inspect for cracks or deterioration before installation, and replace if necessary.

IDENTIFICATION: [P. 6-25](#)

#### GOVERNOR SPRING

REASSEMBLY: Install with the short end side toward the governor arm.

#### FUEL VALVE BRACKET

#### FUEL VALVE

#### GOVERNOR ARM

#### GOVERNOR ARM NUT

10 N•m (7 ft-lb)

#### GOVERNOR ARM BOLT

#### 6 x 12 mm SELF-TAPPING SCREW

2.3 ~ 2.8 N•m (20 ~ 24 in-lb)

#### 7.3 x 160 mm FUEL TUBE

##### REASSEMBLY:

Inspect for cracks or deterioration before installation, and replace if necessary.

IDENTIFICATION: [P. 6-25](#)

B8 TUBE CLIP (2)

6 x 12 mm  
FLANGE BOLT

6 x 28 mm  
FLANGE BOLT

B12 TUBE CLIP (2)

• GCV190N5AV AUTO THROTTLE

Remove the air cleaner and carburetor ([P. 6-7](#)).

GOVERNOR ARM/THROTTLE RETURN SPRING

**INSTALLATION:**

Install the governor rod through the throttle return spring as shown. Connect each to the governor arm and carburetor throttle arm as shown.

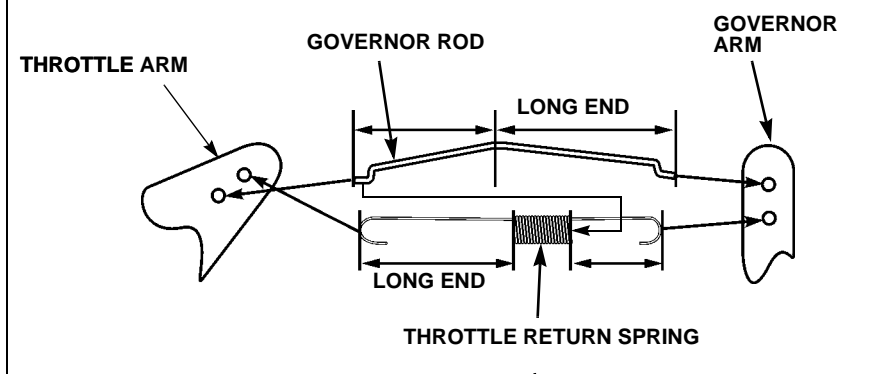

**ENGINE STOP SWITCH**

**INSPECTION:** [P. 6-20](#)

**REMOVAL:**

Lift up the tab with a screwdriver and remove the switch.



**GOVERNOR ARM**

**REASSEMBLY:**

Adjust the governor ([P. 3-16](#)).

**4.5 x 140 mm TUBE**

**REASSEMBLY:**

Inspect for cracks or deterioration before installation, and replace if necessary.

- C8 TUBE CLIP(2)
- WIRE HOLDER
- 6 x 12 mm FLANGE BOLT
- CHOKE ROD GROMMET
- CHOKE ROD
- D8 STYLE HOSE CLAMP (2)
- WIRE HOLDER

**4.5 x 145 mm FUEL TUBE**

**REASSEMBLY:**

Inspect for cracks or deterioration before installation, and replace if necessary. Be sure to replace with the correct fluorinated type fuel tube. **IDENTIFICATION:** [P. 6-25](#)

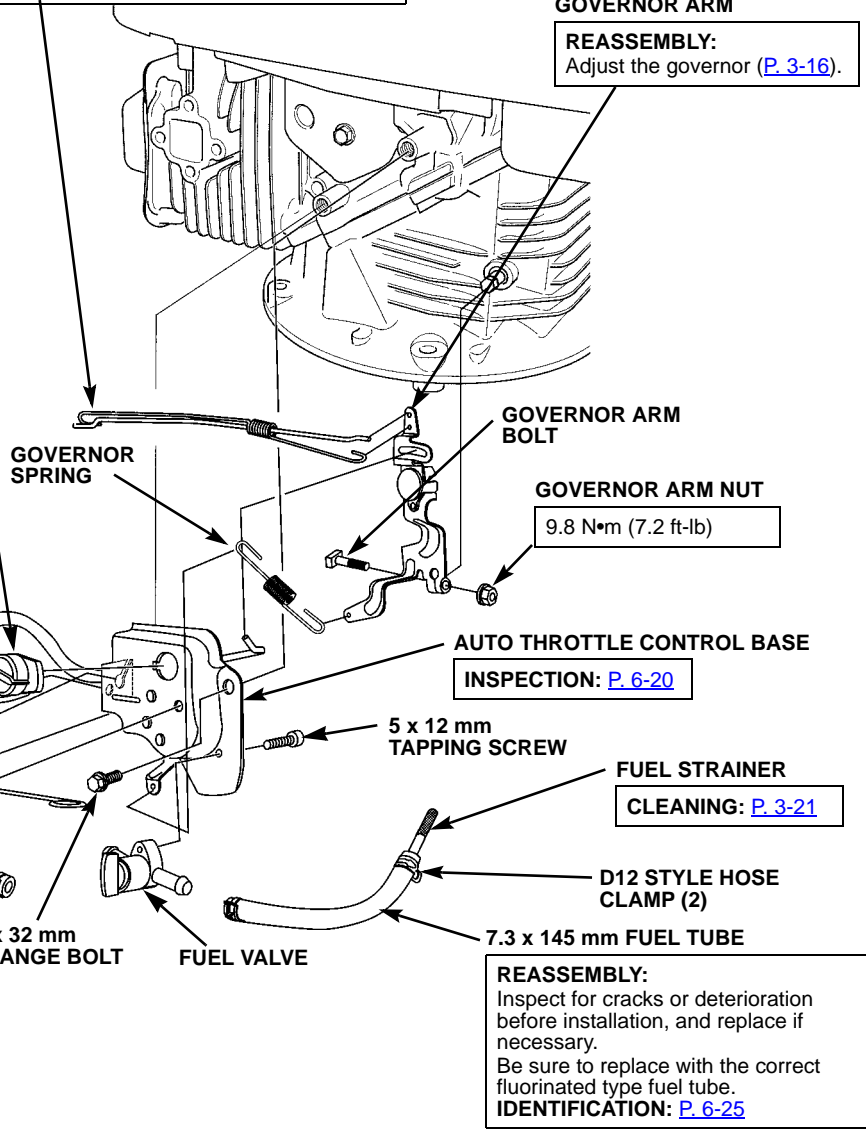

**GOVERNOR ARM BOLT**

**GOVERNOR ARM NUT**  
9.8 N•m (7.2 ft-lb)

**AUTO THROTTLE CONTROL BASE**  
**INSPECTION:** [P. 6-20](#)

**FUEL STRAINER**  
**CLEANING:** [P. 3-21](#)

**REASSEMBLY:**  
Inspect for cracks or deterioration before installation, and replace if necessary. Be sure to replace with the correct fluorinated type fuel tube. **IDENTIFICATION:** [P. 6-25](#)



# FUEL SYSTEM

## INSPECTION

### Engine Switch

#### Rotary type

1. Disconnect the engine switch terminal end from the ignition coil.
2. Turn the switch to both positions and check continuity between the wire and the control base with an ohmmeter.

Switch position	Continuity
ON	No
OFF	Yes

#### Plunger type

There should be continuity when the plunger is pushed in.

There should be no continuity when the plunger is released.

Replace the engine stop switch if the correct continuity test results are not obtained.

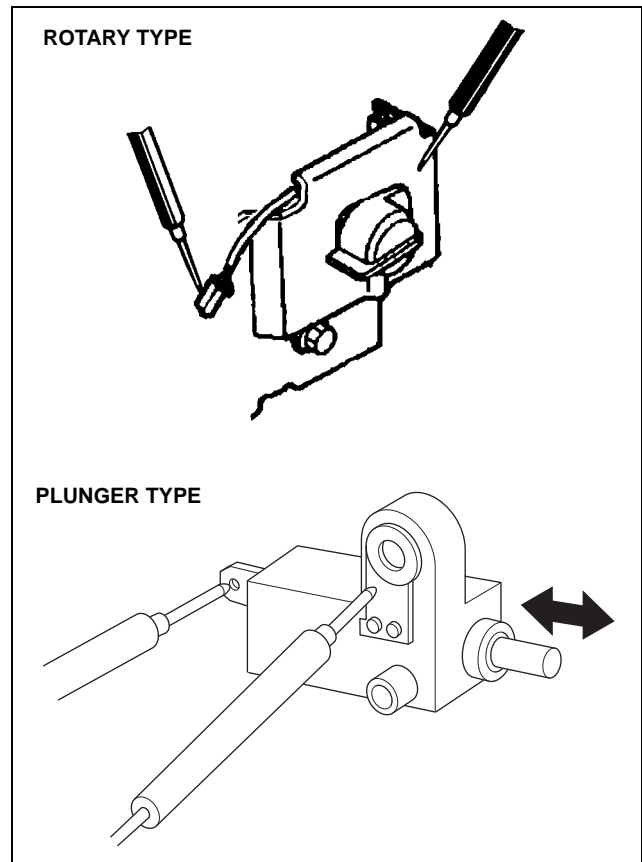

### Auto Throttle Control Base

1. Apply vacuum [15 cmHg (max)(6 inHg)] with a hand-held vacuum pump (commercially available) to the vacuum hose.
2. The vacuum should hold and the actuator arm should stay drawn into the diaphragm assembly.
3. If the vacuum will not hold, check the vacuum hose. If the vacuum hose is normal, replace the Auto Throttle control base.

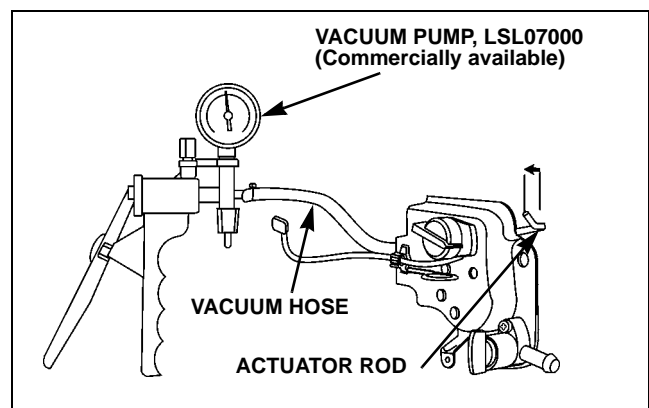

### 3. FAN COVER/FUEL TANK

#### REMOVAL/INSTALLATION

• ONE-PIECE TYPES

1. Before removal, drain the gasoline into an approved container ([P. 3-20](#)).
2. Remove the recoil starter ([P. 5-1](#)).

#### ⚠ WARNING

Gasoline is highly flammable and explosive. You can be burned or seriously injured when handling fuel.

- Keep heat, sparks, and flame away.
- Handle fuel only outdoors.
- Wipe up spills immediately.

#### FUEL TANK CAP

**REASSEMBLY:**  
Make sure that the air vent hole is clean and unclogged. Blow with compressed air if necessary.

#### FAN COVER/FUEL TANK

**CLEANING:** [P. 3-20](#)

**INSTALLATION:**

- Wash with solvent to remove the sediment, and dry thoroughly before installation.
- Check whether the high tension cord and the stop switch wire are securely set in the groove in the fan cover as shown.

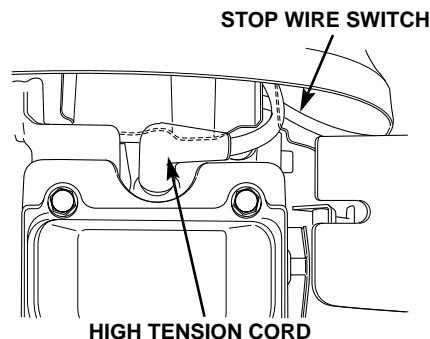

#### FAN COVER COLLAR (3)

Do not lose.

#### FUEL TUBE

**REMOVAL/INSTALLATION:** [P. 6-24](#)

Inspect for cracks or deterioration before installation, and replace if necessary.

**INSPECTION:** [P. 6-24](#)

After installation, inspect for clearance between the fuel tube and equipment frame.

**IDENTIFICATION:** [P. 6-25](#)

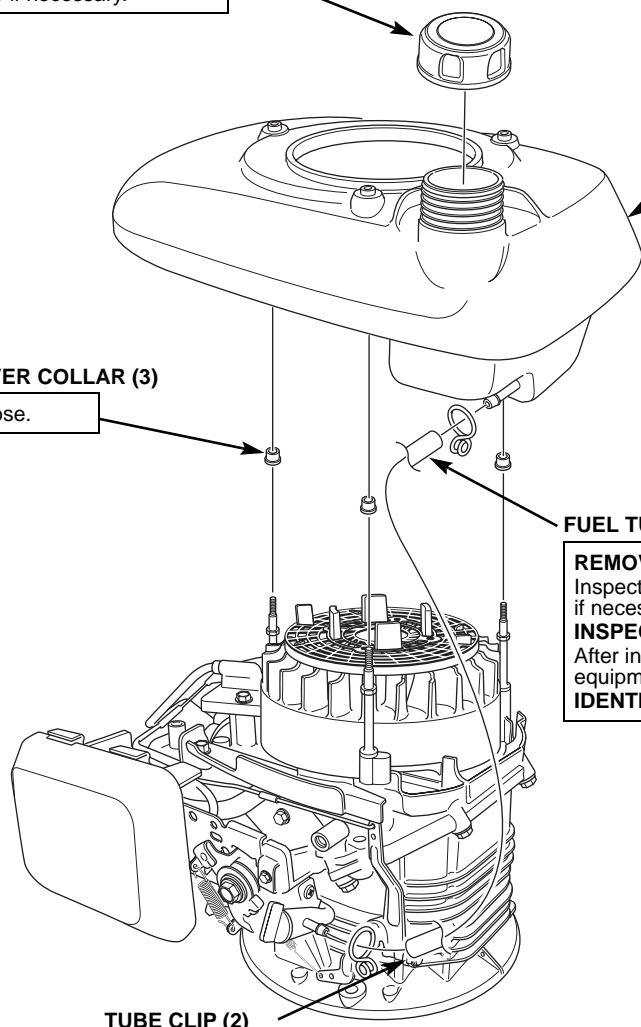

#### TUBE CLIP (2)

# FUEL SYSTEM

## • TWO-PIECE TYPES

### Removal

1. Before removal, drain the gasoline into an approved container.
2. Remove the fuel tube from the fuel tank.
3. Remove the recoil starter ([P. 5-1](#)) and the fan cover.
4. Remove the fuel tank cap from the fuel tank. Unscrew the tether from the fuel filler threads.
5. Unscrew the tank mount nut from the fuel filler threads, and remove the fuel filler neck seal.
6. Using a screwdriver, pry the tank mount clip locking leg from the right tank mount.
7. Slide the fuel tank mount rubber B from the right tank mount, and then remove the fuel tank from the fan cover.
8. Fuel tank reassembly is the reverse order.

### ⚠ WARNING

Gasoline is highly flammable and explosive. You can be burned or seriously injured when handling fuel.

- Keep heat, sparks, and flame away.
- Handle fuel only outdoors.
- Wipe up spills immediately.

#### TANK MOUNT NUT

**INSTALLATION:**  
Gently tighten using tongue and groove pliers, until the alignment mark is positioned between the alignment mark range.

#### FUEL FILLER NECK SEAL

TANK SIDE

#### FAN COVER

**INSTALLATION:** [P. 6-23](#)

#### RUBBER DAMPER PAD (if equipped)

Rubber pad only used on:  
GCV160LAN1A up to serial no. 1134535  
GSV190LAN1L up to serial no. 1064494  
Not used on other models.

**INSTALLATION:**  
Attach the pad to the inside of the fan cover (top and rear).

#### TANK MOUNT RUBBER A

8.0 mm  
(0.31 in)

#### FUEL STRAINER

**CLEANING:**  
Clean with solvent.

#### FUEL TUBE

**REMOVAL/INSTALLATION:** [P. 6-24](#)  
**IDENTIFICATION:** [P. 6-25](#)  
**INSPECTION:** Inspect for cracks or deterioration before installation, and replace if necessary.

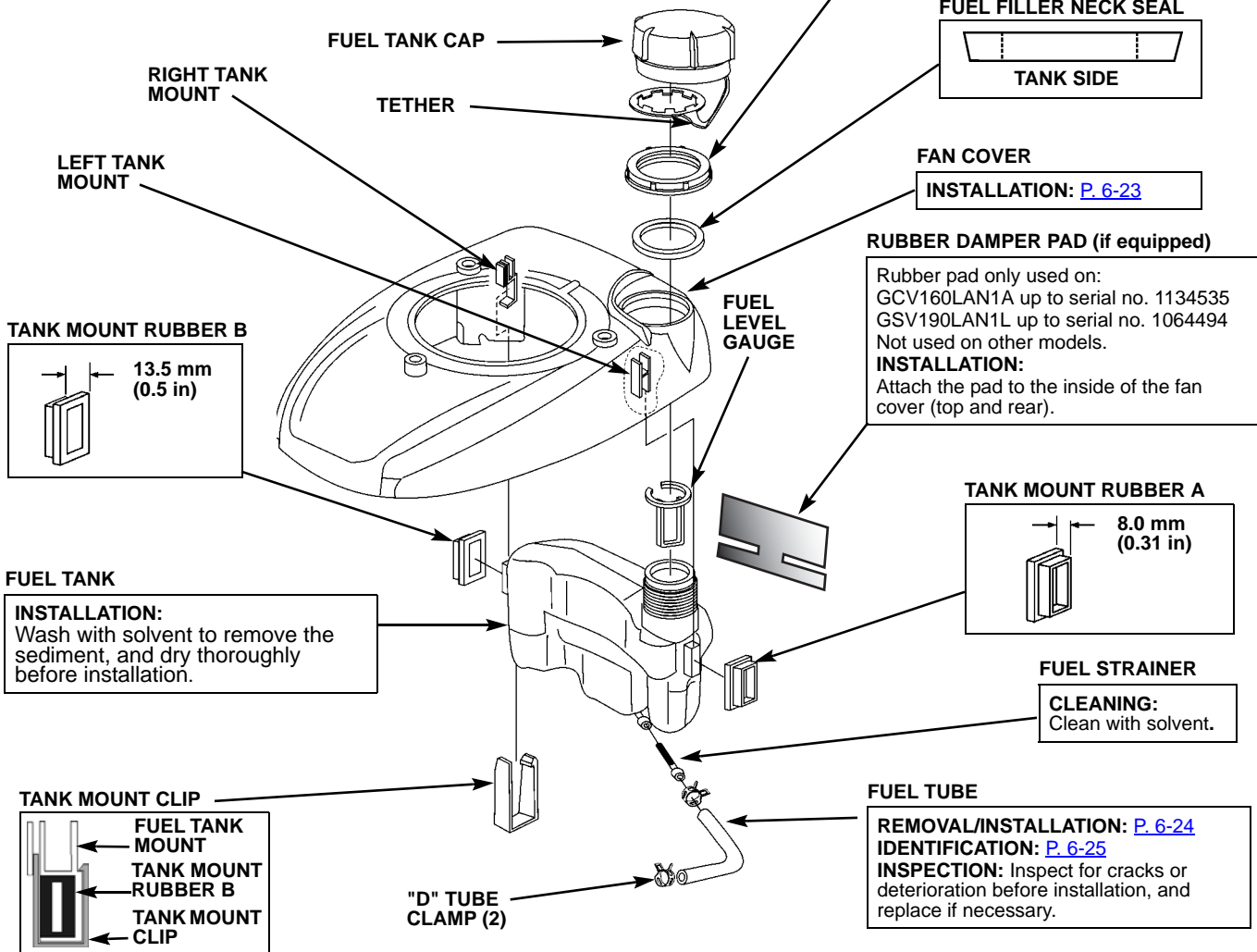

## Installation

### • Cast-Iron Flywheel Type

1. Install the fan cover.
2. Verify that the high tension cord and stop switch lead are positioned as shown in the fan cover cutouts.

FAN COVER AIR GUIDE CUTOUTS

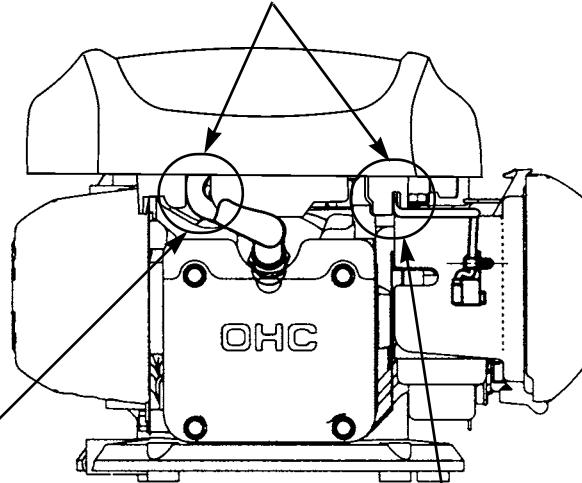

#### HIGH TENSION CORD

**REASSEMBLY:**

Make sure the high tension cord is completely set in the fan cover air guide cutout.

FAN COVER  
AIR GUIDE  
CUTOUT

HIGH TENSION  
CORD

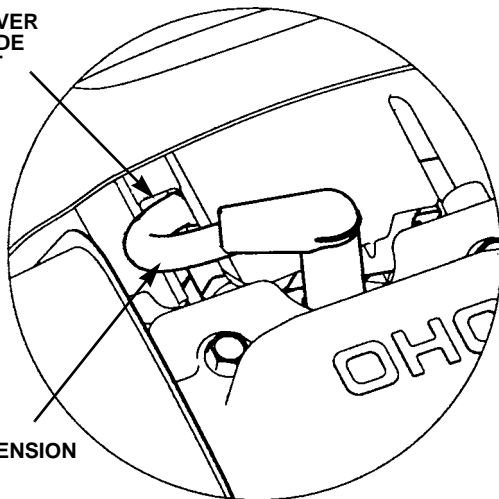

#### STOP SWITCH WIRE

**REASSEMBLY:**

- Make sure the wire is not pinched by the fan cover.
- Make sure the protective tube is installed in the fan cover air guide cutout.

FAN COVER  
AIR GUIDE  
CUTOUT

ENGINE STOP  
SWITCH WIRE

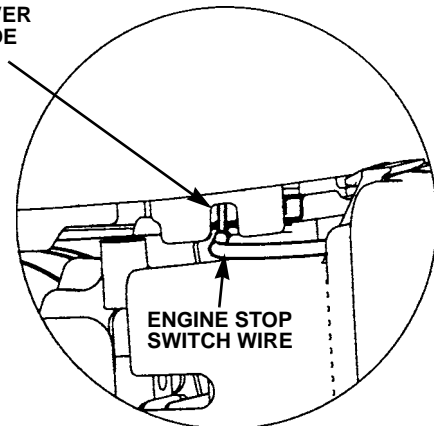

## FUEL SYSTEM

### 4. FUEL TUBE

#### a. REMOVAL/INSTALLATION

1. Turn the fuel valve to the OFF position, and install a fuel tube clamp on the fuel tube.

Use pliers to open the fuel clip, and slide the fuel clip up the tube.

Verify if the fuel tube is the fluorinated type (low-permeability). If so, be sure to replace with the correct fluorinated fuel tube using the fluorinated fuel tube clamps ([P. 6-25](#)).

2. Rotate the fuel tube to help release the tube from the fuel valve fitting.

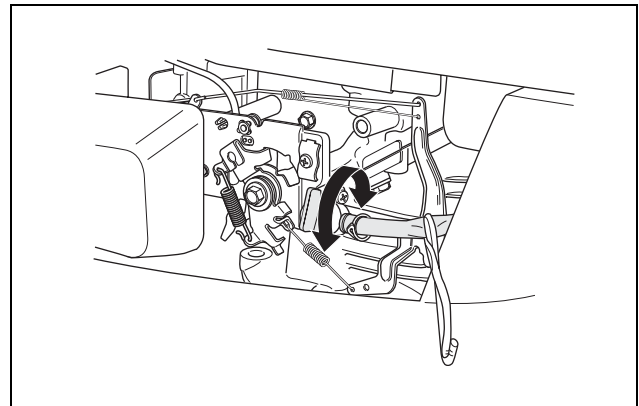
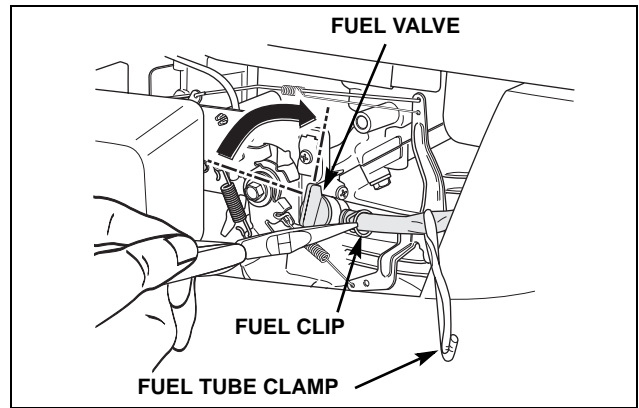

3. Gently pull the fuel tube from the fuel valve. Do not pry against the fuel valve with a screwdriver or other tool when removing the fuel tube.

#### **NOTICE**

*If the fuel tube is pried off the fuel valve with a tool, the fuel valve may become damaged.*

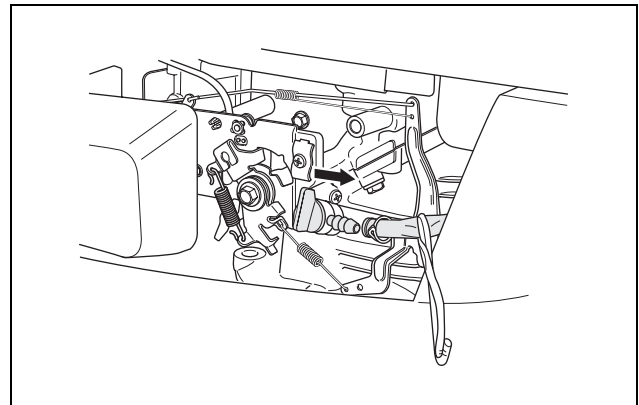

4. Lubricate the fuel tube with silicone spray lubricant and connect the fuel tube to the fuel valve.

Low-permeability fuel tube does not need to be lubricated ([P. 6-25](#)).

5. Position the fuel tube clip over the fuel valve fitting.
6. Remove the fuel tube clamp, and return the fuel valve to the ON position.
7. Check for fuel leaks and repair as necessary.

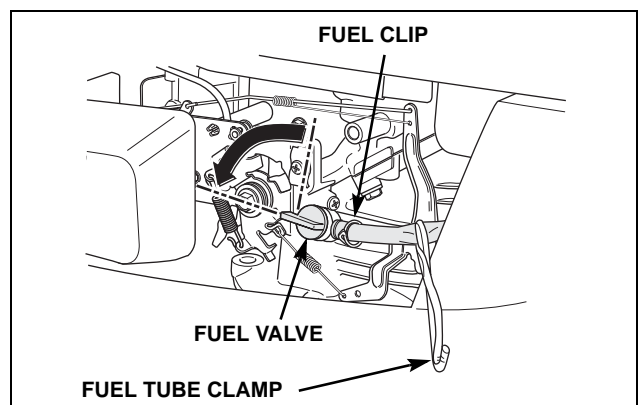

**b. FUEL TUBE AND CLAMP CHANGES**

All Honda Power Equipment manufactured after January 1, 2009, uses low-permeable fuel line. The low-permeable fuel line is easy to spot. The fuel line has the CARB Executive Order (C-U-05-003) printed on it and requires “D” style hose clamps.

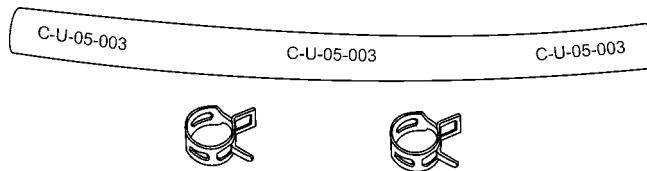

The low-permeable fuel line has a coating on the inside to keep fuel vapors from escaping. The coating makes the inside of the fuel line slick. To ensure the fuel line stays in place, you must only use the “D” style fuel clamps. The old wire-type clamps will not hold the low-permeable fuel line in place.

The old-style fuel line and wire hose clamps are shown below.

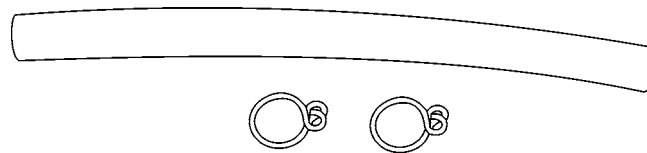

You may use “D” style fuel clamps on the old-style fuel line. But, never use wire fuel line clamps on low-permeable fuel line.

## FUEL SYSTEM

---

# 7. FLYWHEEL/IGNITION COIL/ FLYWHEEL BRAKE

1. ALUMINUM FLYWHEEL TYPES . . . . .	7-1	3. ELECTRIC STARTER TYPES . . . . .	7-9
2. CAST-IRON FLYWHEEL TYPES . . . . .	7-7		

## 1. ALUMINUM FLYWHEEL TYPES DISASSEMBLY/REASSEMBLY

### • With Flywheel Brake

1. Remove the air cleaner and carburetor (P. 6-1).
2. Remove the control base and governor arm (P. 6-15).
3. Remove the fan cover/fuel tank (P. 6-21).

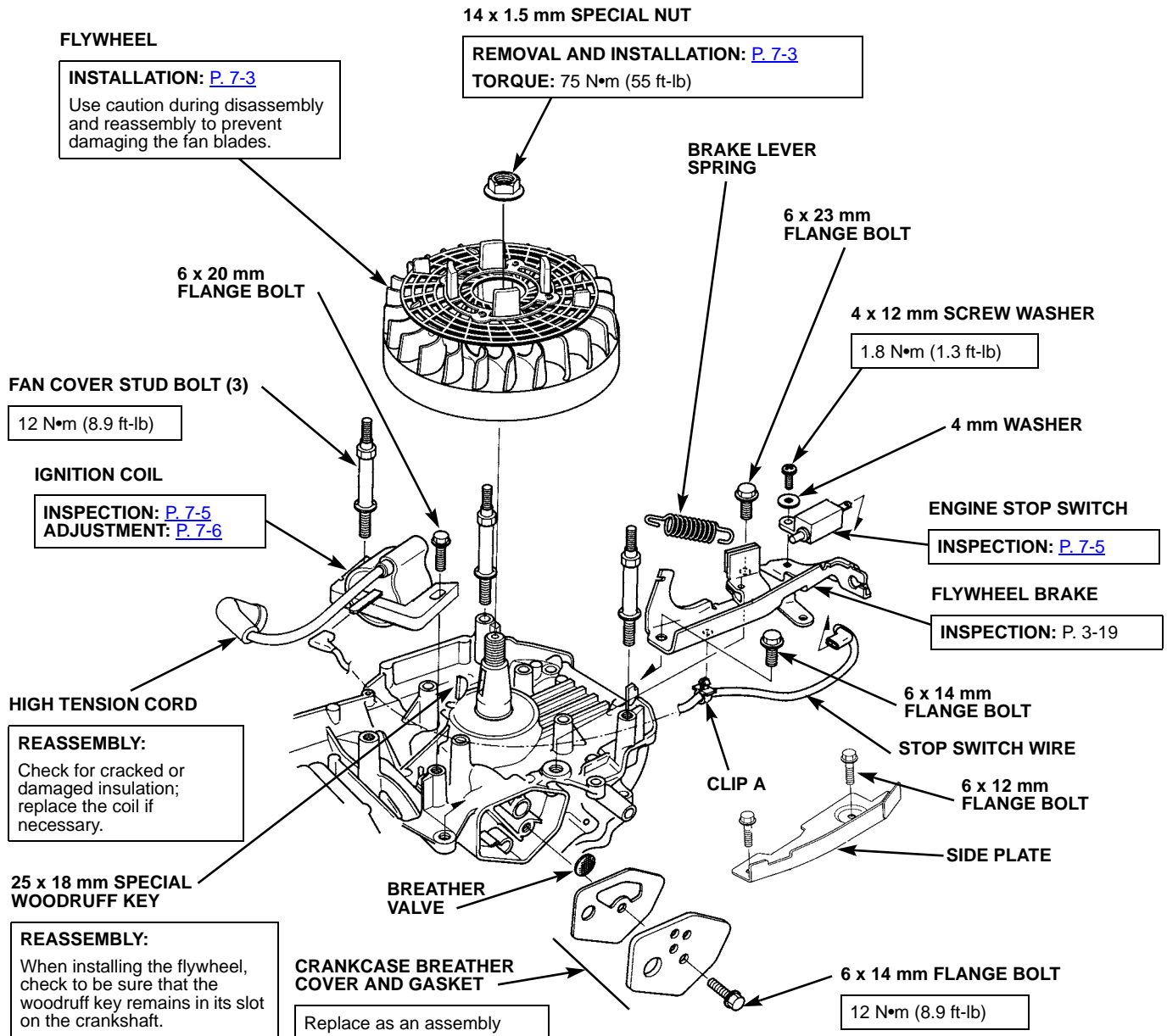



# FLYWHEEL/IGNITION COIL/ FLYWHEEL BRAKE

## • Aluminum Flywheel Without Flywheel Brake

1. Remove the air cleaner and carburetor ([P. 6-1](#)).
2. Remove the control base and governor arm ([P. 6-15](#)).
3. Remove the fan cover/fuel tank ([P. 6-21](#)).

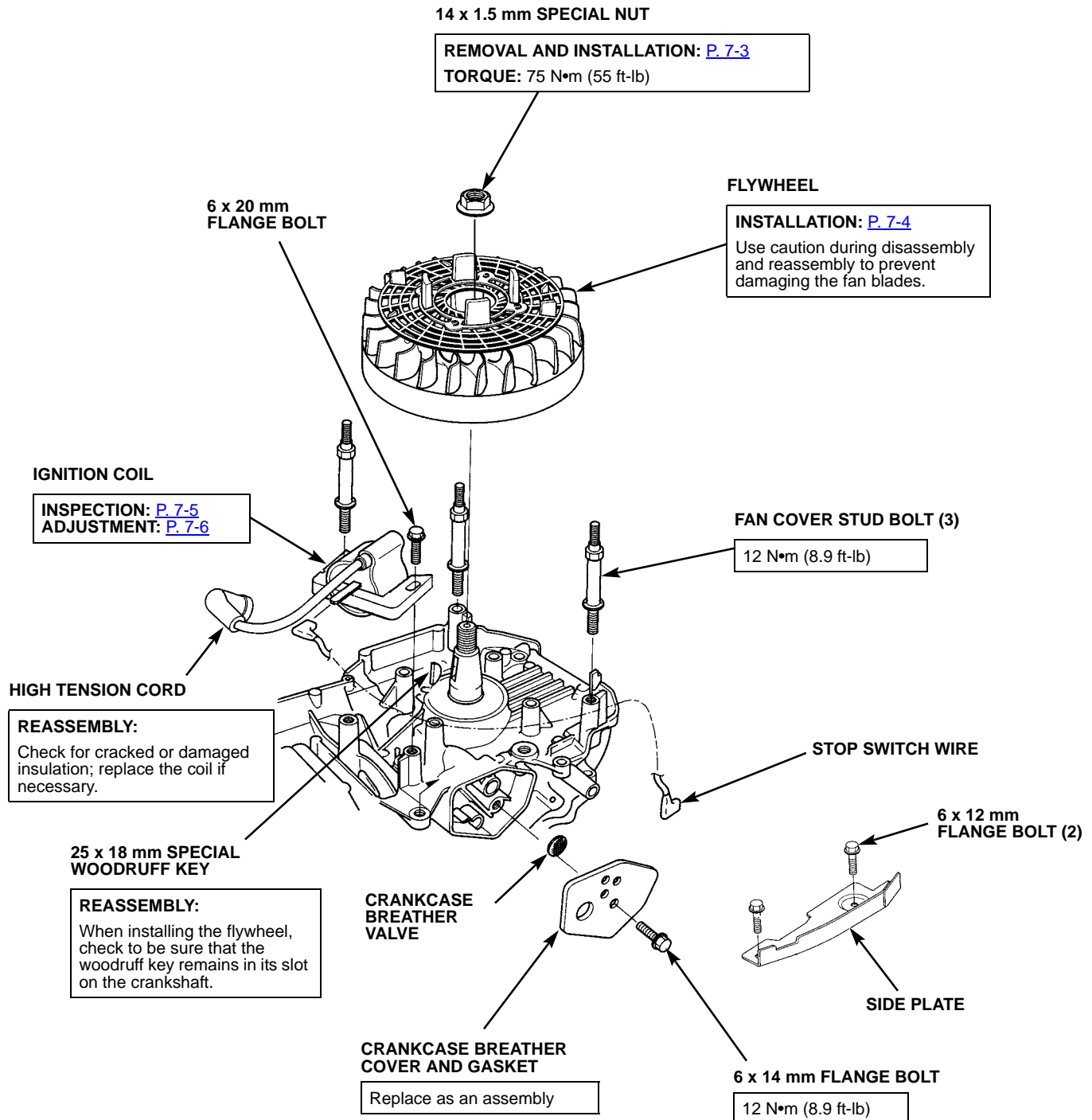

## FLYWHEEL/IGNITION COIL/ FLYWHEEL BRAKE

### • 14 mm SPECIAL NUT/FLYWHEEL

#### REMOVAL

1. Remove the fan cover/fuel tank ([P. 6-21](#)).
2. On flywheel brake types, pull the flywheel brake lever and secure the lever to the handlebar with a strap or equivalent material. This allows the flywheel and crankshaft to turn.

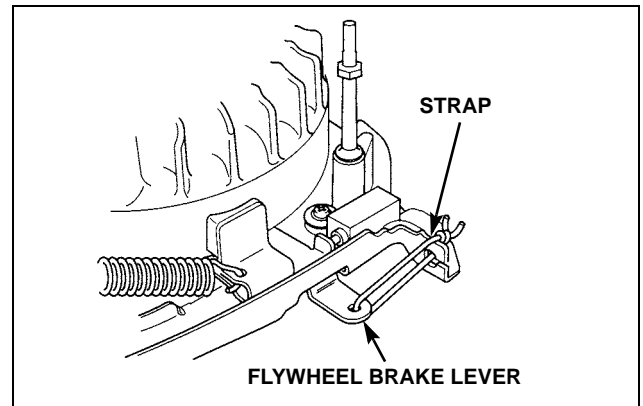

3. Holding the flywheel with a commercially available strap wrench, remove the 14 mm special nut.

#### **NOTICE**

*Inserting a rod or screwdriver in the fan blades can damage the blades or the aluminum casting projections.*

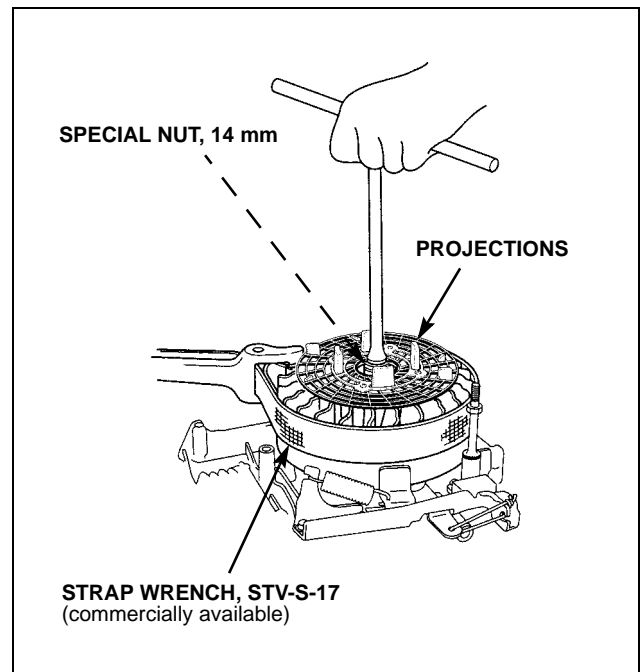

4. Position the flywheel magnets (identified by the PULLER mark) in the position shown.

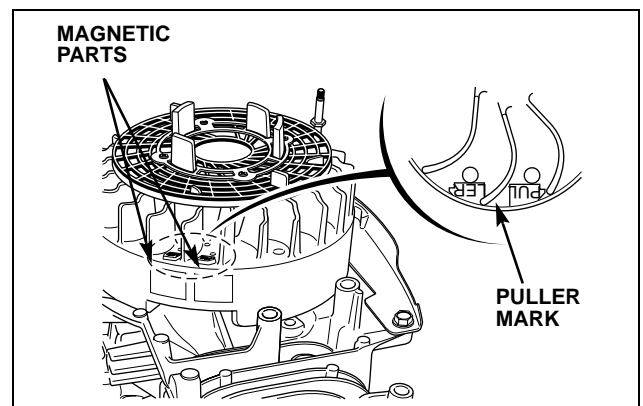

## FLYWHEEL/IGNITION COIL/ FLYWHEEL BRAKE

5. Position a commercially available 6-inch flywheel puller on the flywheel with one of the puller jaws under the magnets (at the PULLER mark).

Set a shop towel or equivalent cloth between the flywheel and the puller.

Tighten the flywheel puller and then tap the end of the puller to remove the flywheel.

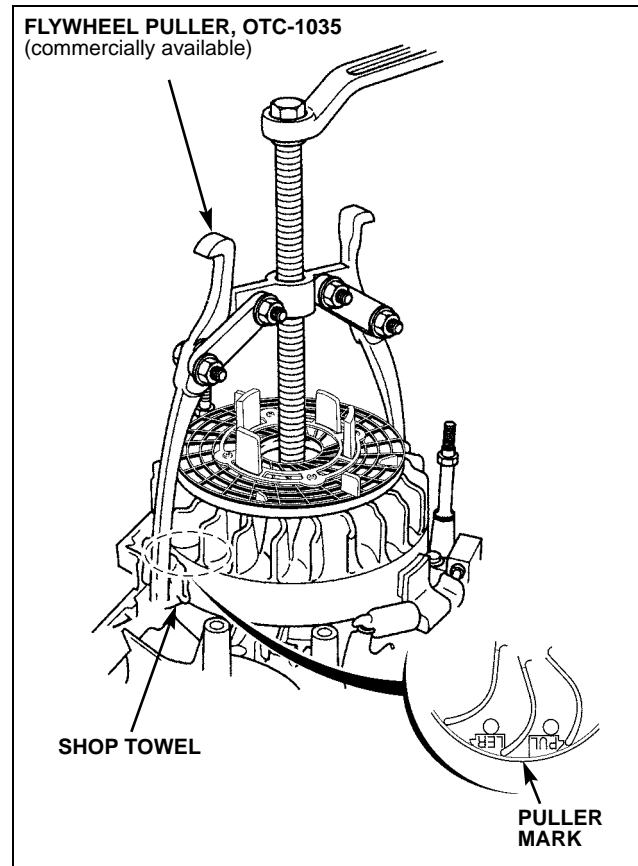

### INSTALLATION

Make sure the flywheel taper is free of dirt, oil, grease and other foreign material before installation.

Also, make sure there is no foreign material on the magnets.

1. Be sure the woodruff key is set in the keyway properly.
2. Install the flywheel.
3. Apply oil to the threads.
4. Holding the flywheel with a commercially available strap wrench, tighten the 14 mm special nut.

**TORQUE: 75 N•m (55 ft-lb)**

5. On flywheel brake types, remove the strap or equivalent material from the flywheel brake lever.
6. Install the ignition coil ([P. 7-1](#)).
7. Install the fan cover/fuel tank ([P. 6-21](#)).
8. On flywheel brake types, check the operation of the flywheel brake ([P. 3-19](#)).

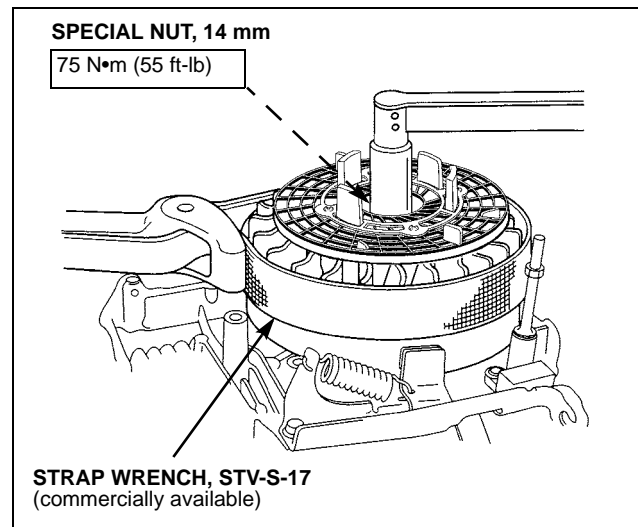

**• ENGINE STOP SWITCH  
INSTALLATION**

The engine stop switch is different between the flywheel brake and non-flywheel brake models.

Install the proper engine switch.

**<Type Identification>**

With flywheel brake: Stamped as “N CL”

Without flywheel brake: Stamped as “N OP”

**INSPECTION**

**• Ignition Coil**

**<Primary Resistance>**

Measure the resistance of the primary coil by attaching one ohmmeter lead to the ignition coil's primary terminal while touching the other test lead to the iron core.

Primary side resistance	1.0 ~ 1.2 $\Omega$
-------------------------	--------------------

**<Secondary Resistance>**

Attach an ohmmeter lead between the spark plug cap and the iron core, and measure the resistance of the secondary coil.

Secondary side resistance	10.6 ~ 12.8 k $\Omega$
---------------------------	------------------------

**• Engine Stop Switch**

**<With flywheel brake>**

There should be no continuity when the plunger is pushed in.

There should be continuity when the plunger is released.

**<Without flywheel brake>**

There should be continuity when the plunger is pushed in.

There should be no continuity when the plunger is released.

Replace the engine stop switch if the correct continuity test results are not obtained.

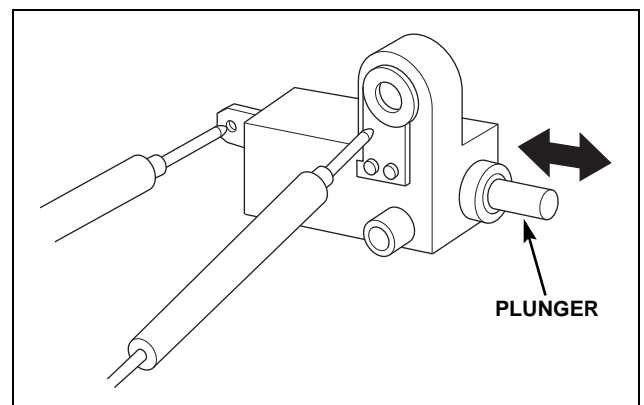
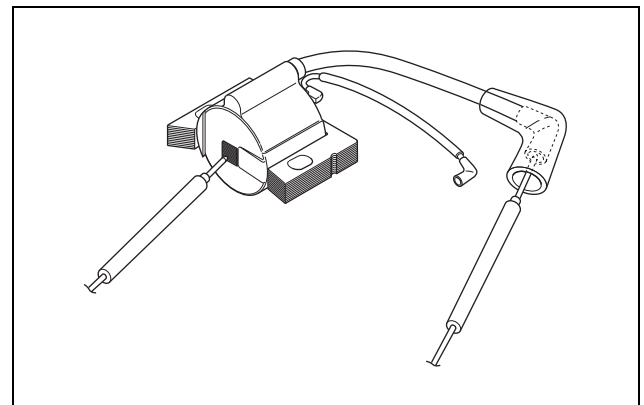
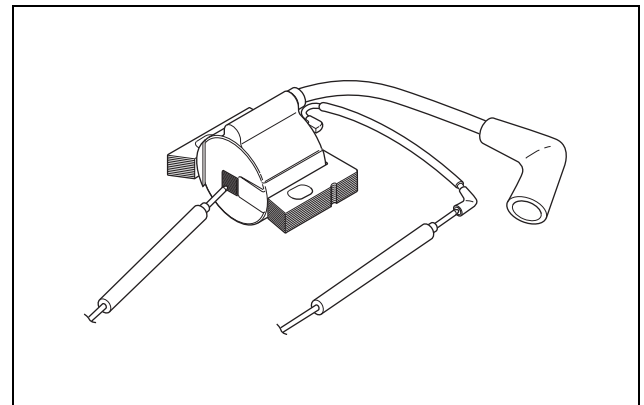
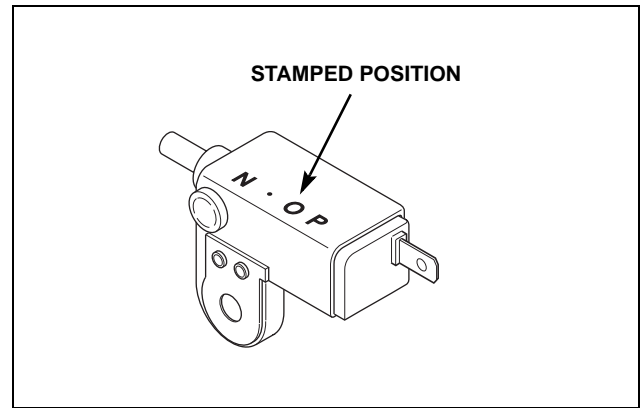

# FLYWHEEL/IGNITION COIL/ FLYWHEEL BRAKE

## ADJUSTMENT

### Ignition Coil Air Gap

Adjustment is required only when the ignition coil or flywheel has been removed.

1. Loosen the ignition coil bolts.
2. Insert a long feeler gauge of the proper thickness between the ignition coil and the flywheel.

Both gaps should be adjusted simultaneously.

Specified clearance	0.2 ~ 0.6 mm (0.008 ~ 0.024 in)
---------------------	------------------------------------

3. Push the ignition coil firmly toward the flywheel and tighten the bolts.

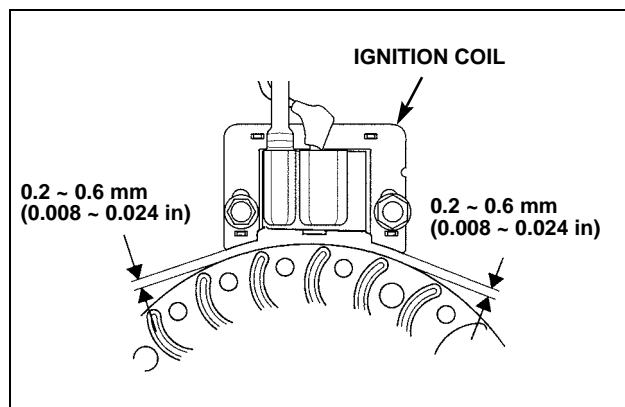
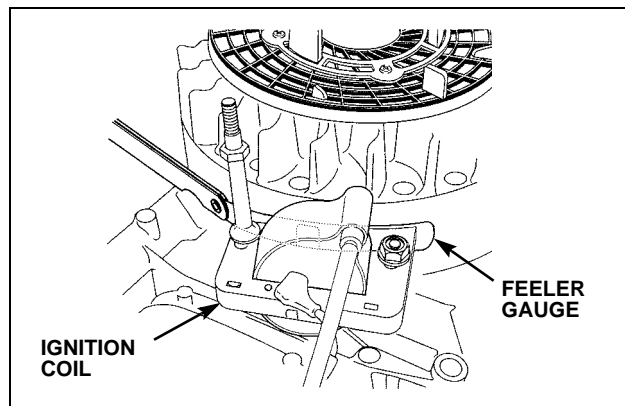

## 2. CAST-IRON FLYWHEEL TYPES

### DISASSEMBLY/REASSEMBLY

1. Remove the recoil starter ([P. 5-1](#)) and fan cover ([P. 6-21](#)).
2. Remove the fan cover stud (dark gray), the 6 x 23 mm flange bolt, and the ignition coil.
3. Remove the 14 mm special nut and the flywheel.

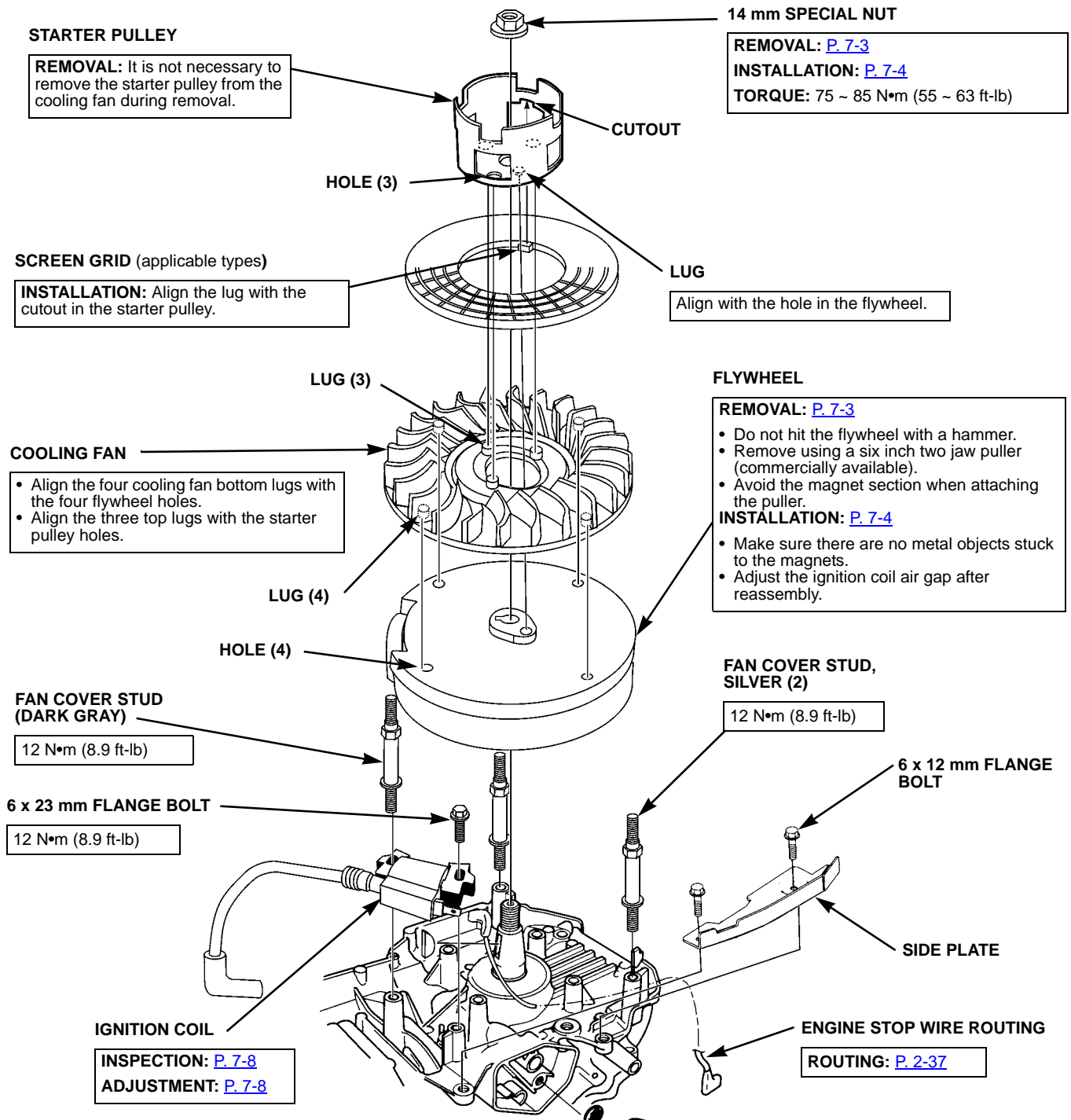

# FLYWHEEL/IGNITION COIL/ FLYWHEEL BRAKE

## INSPECTION

### Transistorized Ignition Coil

#### Cast-Iron Flywheel Type

##### Primary Side

Measure the resistance of the primary coil by attaching one ohmmeter lead to the ignition coil's primary terminal while touching the other test lead to the iron core.

Primary Side Resistance	0.68 ~ 0.84 $\Omega$
-------------------------	----------------------

##### Secondary Side

Measure the resistance of the secondary side of the coil by attaching one lead of the ohmmeter to the spark plug wire (high tension lead) and the other test lead to the iron core.

Secondary Side Resistance	5.6 ~ 6.9 k $\Omega$
---------------------------	----------------------

If the resistance is not within specification, replace the ignition coil.

## ADJUSTMENT

### Ignition Coil Air Gap

#### Cast-Iron Flywheel Type

Adjustment is required only when the ignition coil or the flywheel has been removed.

1. Loosen the ignition bolts.
2. Insert a long feeler gauge of the proper thickness between two legs of the coil assembly.
  - Avoid the flywheel magnet.
  - Both gaps must be adjusted simultaneously.
3. Push the coil assembly firmly toward the flywheel and tighten the bolts.

Specified clearance	0.2 ~ 0.5 mm (0.008 ~ 0.020 in)
---------------------	------------------------------------

PRIMARY SIDE

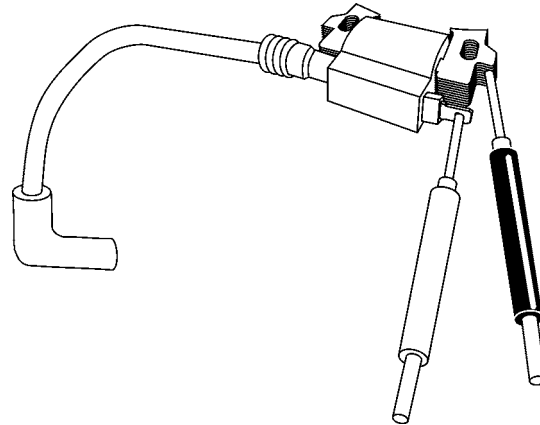

SECONDARY SIDE

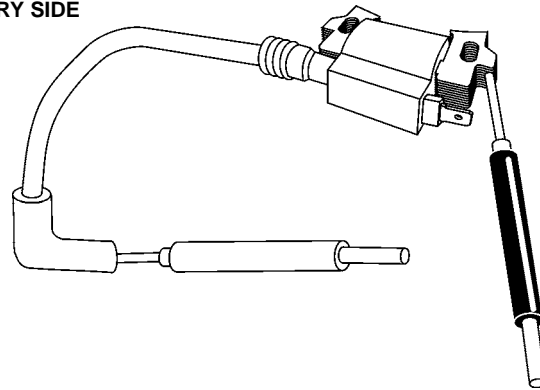

FEELER GAUGE

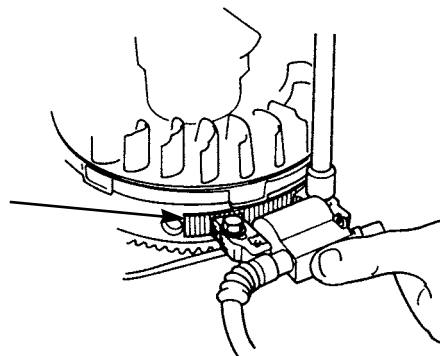

FLYWHEEL

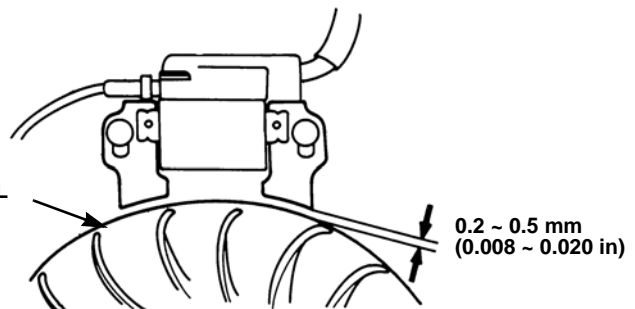

### 3. ELECTRIC STARTER TYPES

#### DISASSEMBLY/REASSEMBLY

1. Remove the recoil starter (P. 5-1) and fan cover (P. 6-21).
2. Remove the fan cover stud, the 6 x 20 mm flange bolt and the ignition coil.
3. Remove the 14 mm special nut and the flywheel.
4. Remove the wires from the brake assembly then remove the 6 x 23 mm and 6 x 14 mm flange bolts and the brake assembly.

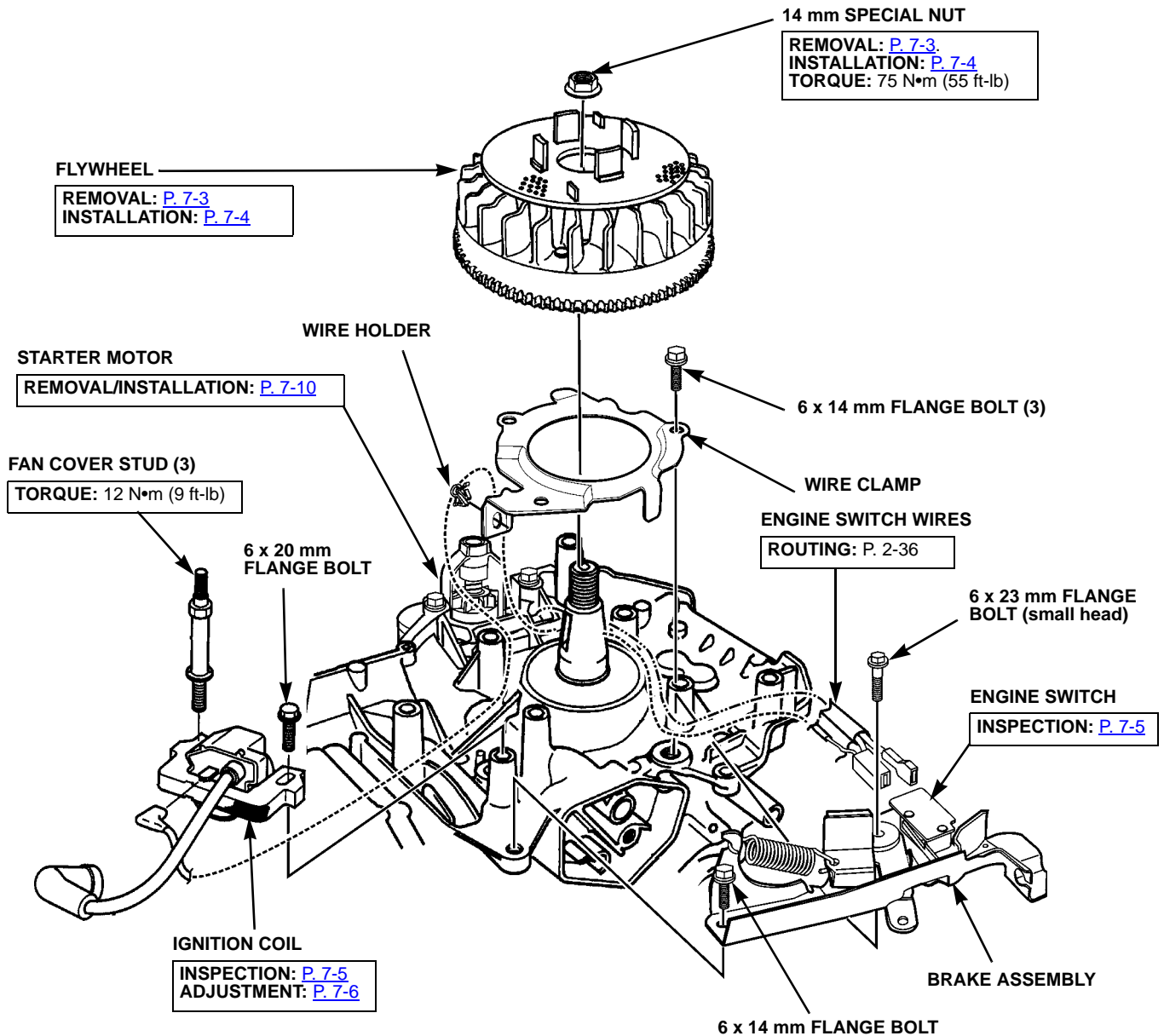



# FLYWHEEL/IGNITION COIL/ FLYWHEEL BRAKE

## REMOVAL/INSTALLATION

### • STARTER MOTOR

1. Remove the recoil starter ([P. 5-1](#)) and fan cover ([P. 6-21](#)).  
It is not necessary to remove the flywheel to remove the starter motor.
2. Loosen the oil filler cap/dipstick.
3. Remove the 5 x 8 mm pan screw and the black wire from the starter motor.
4. Remove the red wire from the starter motor negative terminal.

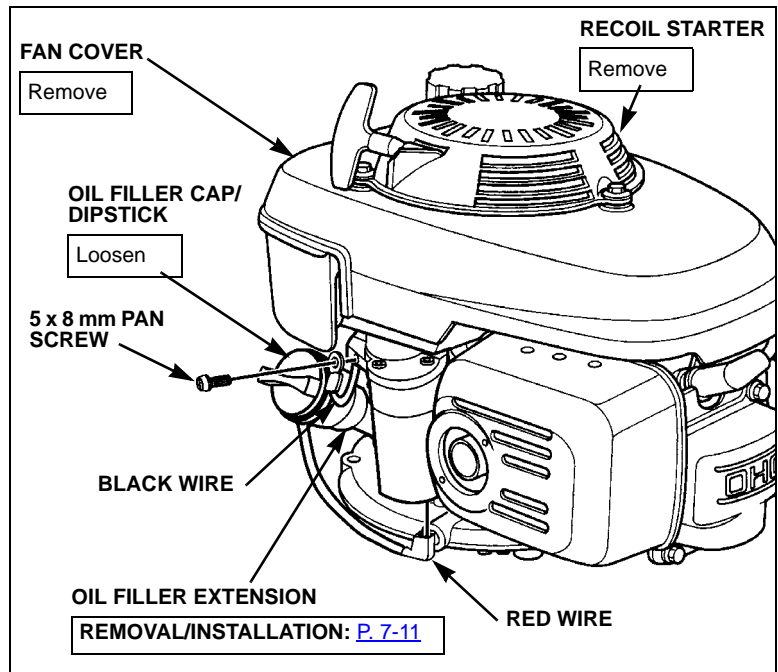

5. Remove wire clip A from the starter motor.
6. Remove the two 6 mm special bolts and the starter motor.
7. Install in the order reverse order of removal.

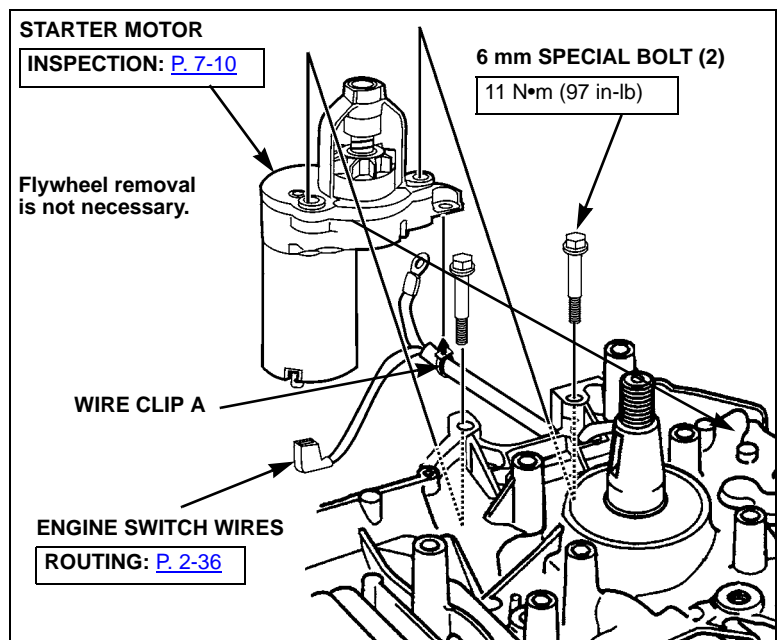

• **Oil Filler Extension**

*Removal*

1. Flatten the locking edges of the extension lock washer.
2. Unscrew the oil filler extension and extension lock washer.

*Installation*

1. Install a new 14.8 x 2.4 mm O-ring on the oil filler extension.
2. Install the extension lock washer on the engine with its notch aligning with the engine oil fill hole projection.
3. Hand tighten the oil filler extension until the O-ring is compressed.
4. Bend up the extension lock washer edges to secure two sides of the oil filler extension.

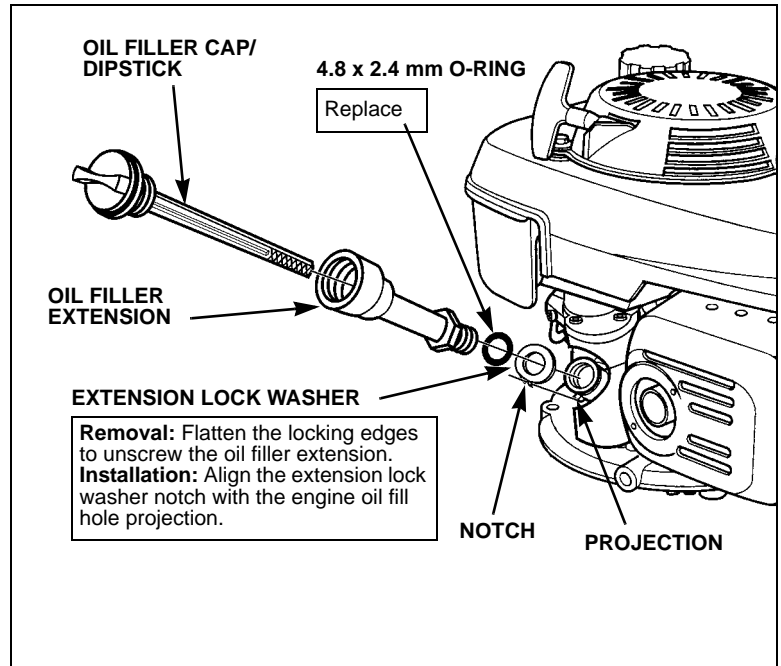

**INSPECTION**

• **Starter Motor**

Measure the starter motor performance while cranking the engine with a fully charged 12 Vdc battery.

If performance is not within specification, replace the starter motor.

	<b>Under Load</b>	<b>No Load</b>
Cranking Voltage	8.5 VDC	10.4 VDC
Cranking Current	Below 45 A	Below 20 A
Engine Cranking Speed	More than 350 rpm	

# FLYWHEEL/IGNITION COIL/ FLYWHEEL BRAKE

## • CLEANING AND INSPECTING THE PINION DAMPER ASSEMBLY

1. Remove the starter motor ([P. 7-10](#)).

2. Separate the pinion rubber damper from the drive plate.

Using your thumbs, push the pinion vertically on the shaft, in the direction shown. Do not rotate the pinion assembly.

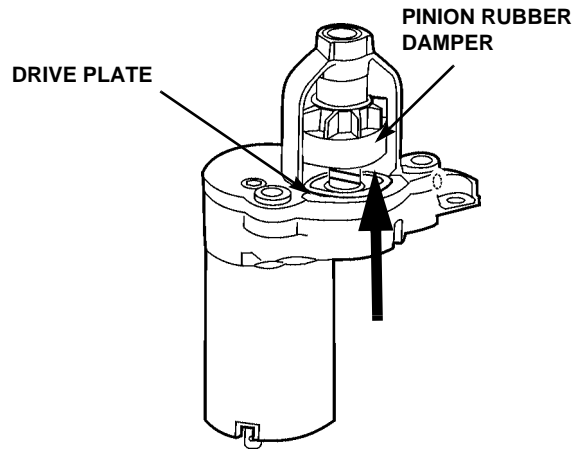

3. Thoroughly clean between the drive plate and damper using a rubber-compatible contact cleaner or brake cleaner. Use a cotton swab or other utensil to remove any residue from the damper rubber and drive plate.

Do not use compressed air to remove residue as it may force cleaner or debris into the starter gearbox.

4. After cleaning, verify no oil or grease residue is present and the damper and drive plate are dry.

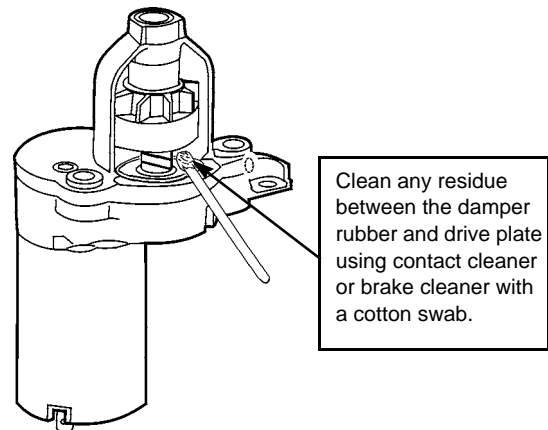

5. Inspect the rubber damper seal for damage. Replace the starter if the rubber damper is damaged or will not seat properly around the drive plate.

6. Firmly push the pinion rubber damper down over the drive plate.

Make sure the damper rubber seal lip is properly positioned and seated around the drive plate.

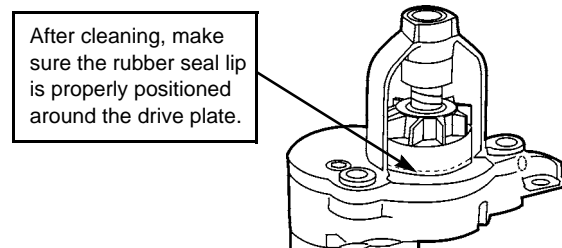

7. Rotate the pinion clockwise as shown to verify that the pinion and drive plate assembly climb up the shaft.

8. Reinstall the starter motor and test for proper operation.

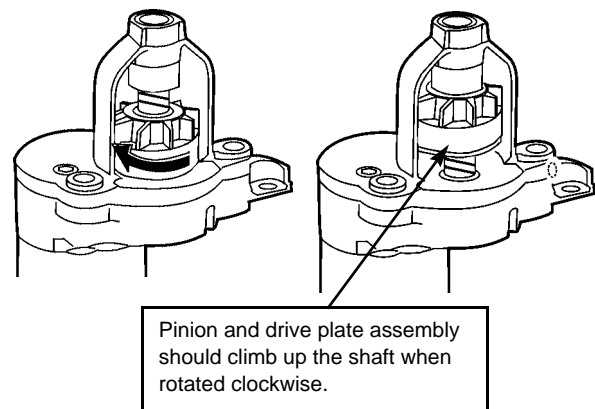

## FLYWHEEL/IGNITION COIL/ FLYWHEEL BRAKE

### • Engine Switch

#### *Ignition Coil Side*

1. Attach a VOM's test leads between the ignition coil black wire and the eyelet terminal black wire.
2. There should be continuity with the engine switch in the OFF position, and no continuity in the ON position.

#### *Starter Side*

1. Attach a VOM's test leads between the starter motor red wire and the eyelet terminal black wire.
2. There should be continuity with the engine switch in the ON position, and no continuity in the OFF position.

If any of the above tests fail, inspect each wire for continuity. If the wires are all good, replace the brake assembly.

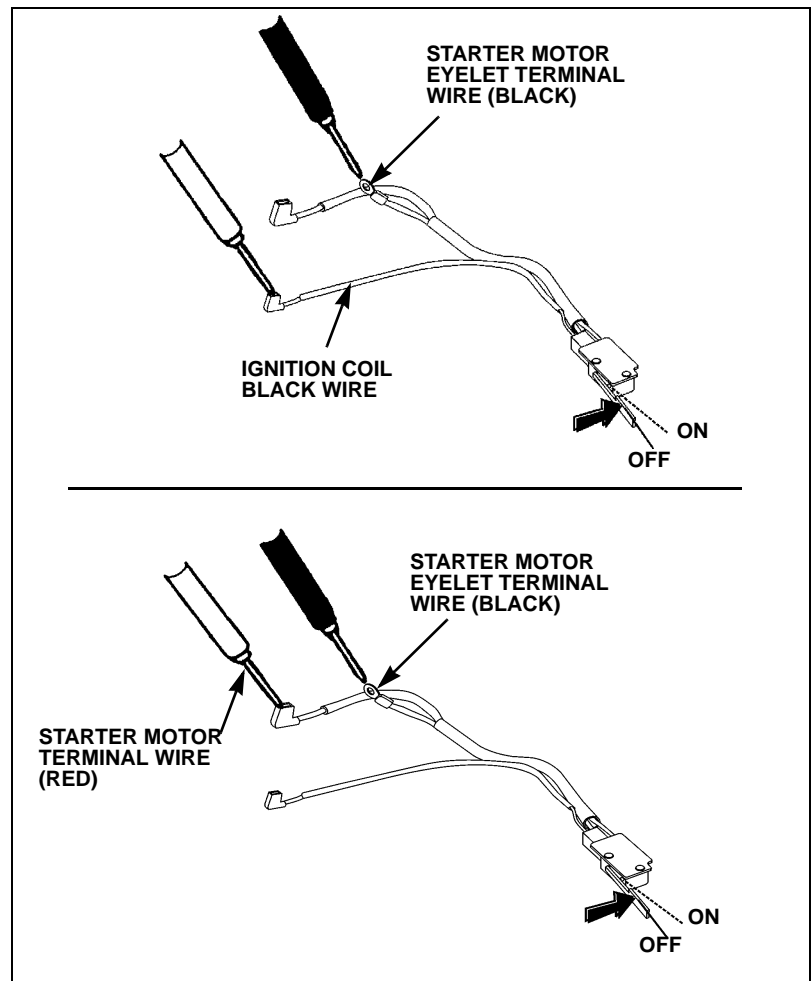

**FLYWHEEL/IGNITION COIL/  
FLYWHEEL BRAKE**

---

# 8. CAM PULLEY/CRANKSHAFT/ PISTON/CYLINDER BLOCK

1. CAM PULLEY/ROCKER ARM.....	8-1	4. VALVES .....	8-9
2. OIL PAN/CRANKSHAFT/ CYLINDER BLOCK .....	8-4	5. GOVERNOR.....	8-11
3. PISTON .....	8-7	6. VALVE SEAT RECONDITIONING.....	8-20

## 1. CAM PULLEY/ROCKER ARM

### REMOVAL/INSTALLATION

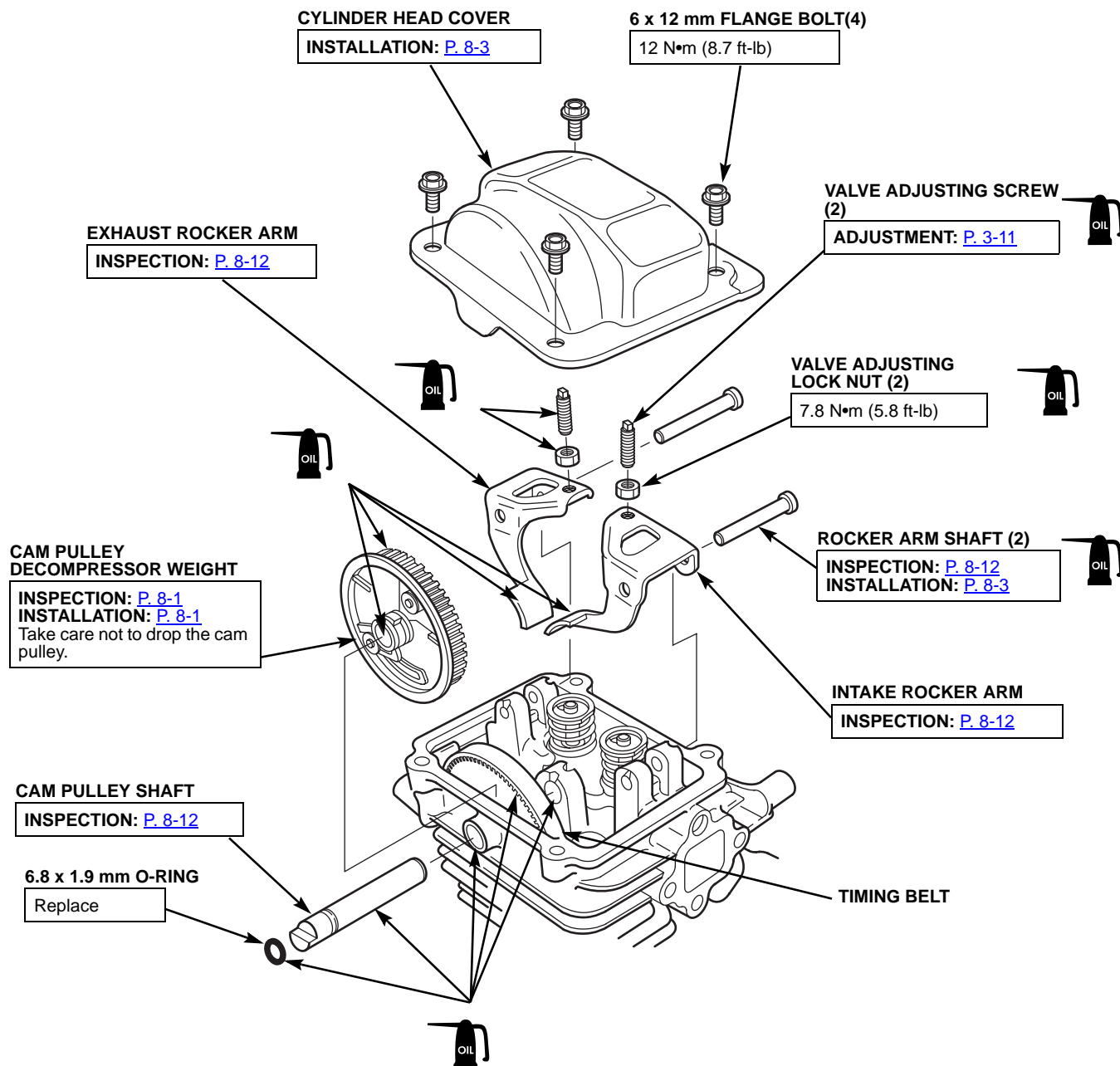

- CAM PULLEY DECOMPRESSION WEIGHT INSPECTION

# CAM PULLEY/CRANKSHAFT/ PISTON/CYLINDER BLOCK

Before installing, inspect for worn and weakened springs, and check that the decompressor weight moves smoothly.

## INSTALLATION

1. Turn the crankshaft so the two woodruff key grooves on the PTO side face down.
2. Install the cam pulley on the timing belt so the cam pulley alignment marks are in line with the cylinder head cover mating surfaces.

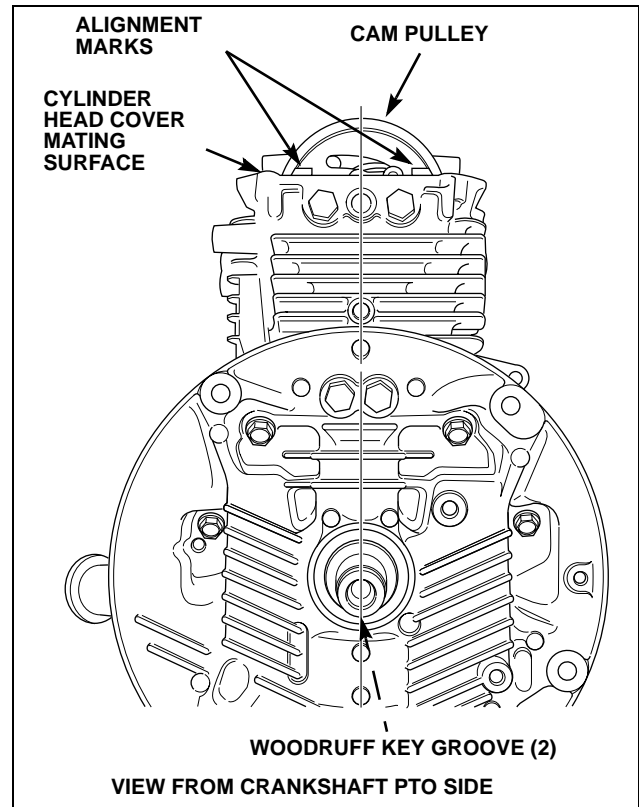
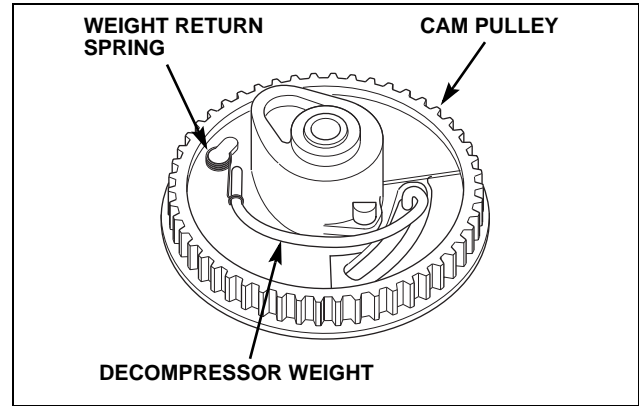

3. Apply oil to the O-ring and install the o-ring on the cam pulley shaft.
4. Install the cam pulley shaft in the cylinder block.
5. Holding the cam pulley alignment marks in line with the cylinder head cover mating surface, make sure the two woodruff key grooves are facing down.
6. If the two woodruff key grooves are not facing down, repeat the procedure from step 1.

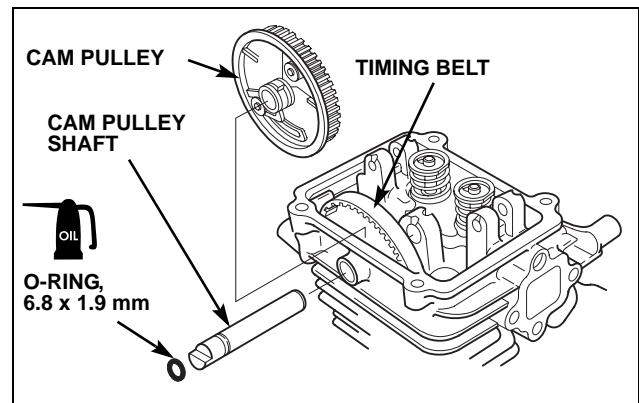

## CAM PULLEY/CRANKSHAFT/ PISTON/CYLINDER BLOCK

### • ROCKER ARM SHAFT INSTALLATION

Install the rocker arm shaft from the opposite side of the cam pulley as shown.

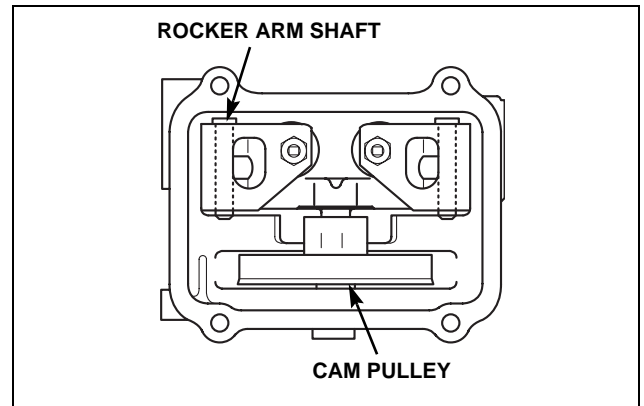

### • CYLINDER HEAD COVER INSTALLATION

Do not reuse the original cover if it is bent or damaged.

1. Clean the mating surfaces of the cylinder head cover and the cylinder block using a degreasing cleaning agent and a clean shop towel.
2. Apply liquid gasket (Hondabond HT or Threebond 1216) to the cylinder head cover, specifically to the inner wall of the groove and bolt hole in the cylinder head cover.

Assemble within 10 minutes after applying the liquid gasket.

3. Wait for approximately 20 minutes after assembly before filling with oil and starting the engine.

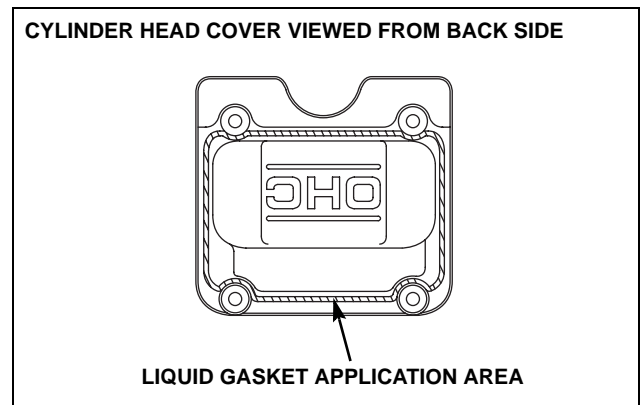



# CAM PULLEY/CRANKSHAFT/ PISTON/CYLINDER BLOCK

## 2. OIL PAN/CRANKSHAFT/CYLINDER BLOCK

### REMOVAL/INSTALLATION

Remove the cam pulley and rocker arms.

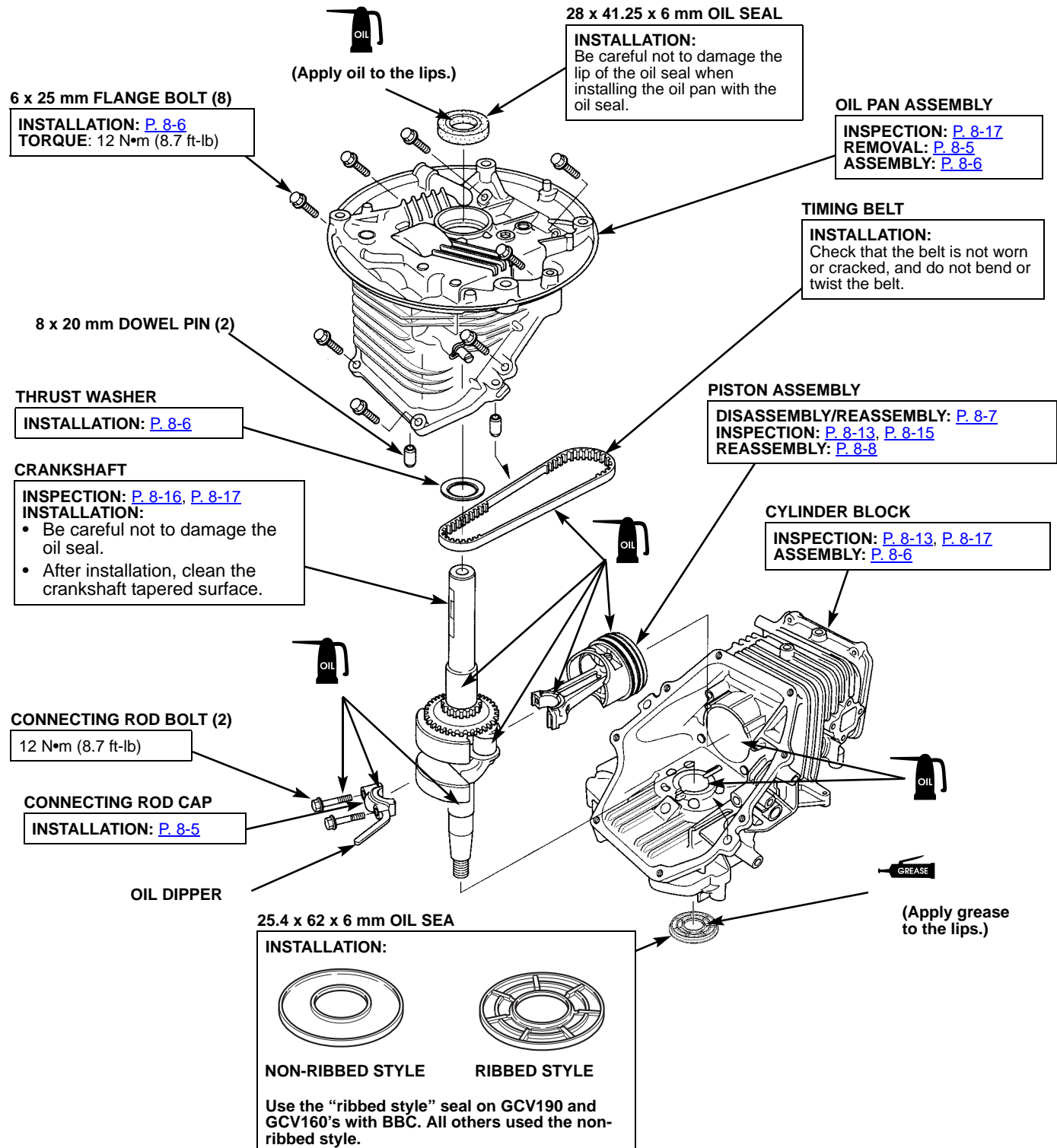

## CAM PULLEY/CRANKSHAFT/ PISTON/CYLINDER BLOCK

### • OIL PAN REMOVAL

1. Set the piston at top dead center of the compression stroke.
2. Remove the 6 x 25 mm flange bolts.
3. Insert a screwdriver or equivalent tool into the recesses as shown, and remove the oil pan from the cylinder block.

Be careful not to damage the sealing surfaces. Use a tool that fits tightly into the recesses. Twist the tool to break sealant loose. Do not drive the tool into the sealing surfaces with a hammer.

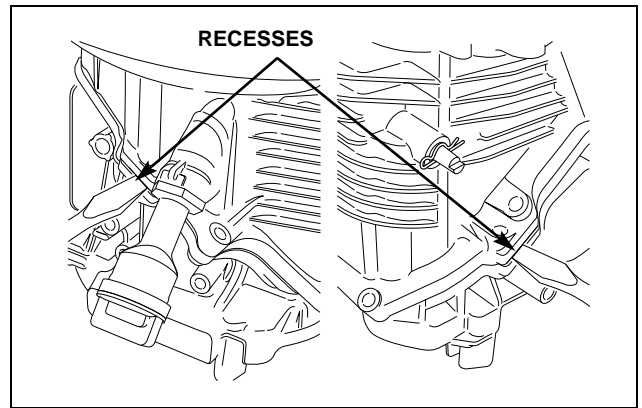

### • PISTON ASSEMBLY/CONNECTING ROD CAP INSTALLATION

1. Apply clean engine oil to the cylinder wall and the outer surface of the piston.
2. Install the piston assembly into the cylinder so that the "FW ▽" mark stamped on the back side of the piston crown points toward the flywheel side.

The model mark near the piston pin bore will be facing the oil pan.

#### NOTICE

*Take care not to break the piston rings when installing the piston assembly into the cylinder block.*

Push the piston up to top dead center.

3. Apply clean engine oil to the cylinder block crankshaft bearing area, and install the crankshaft into the cylinder block.
4. Apply oil to the connecting rod big end bearing and the crank pin; then connect the connecting rod to the crank pin.
5. Apply oil to the connecting rod cap bearing.
6. Install the connecting rod cap so that the projection near the oil dipper and the projection on the connecting rod are aligned.
7. Tighten the connecting rod bolts to the specified torque.

**TORQUE: 12 N•m (8.7 ft-lb)**

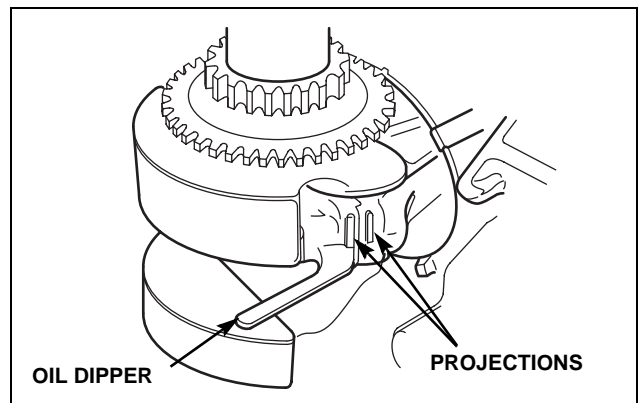
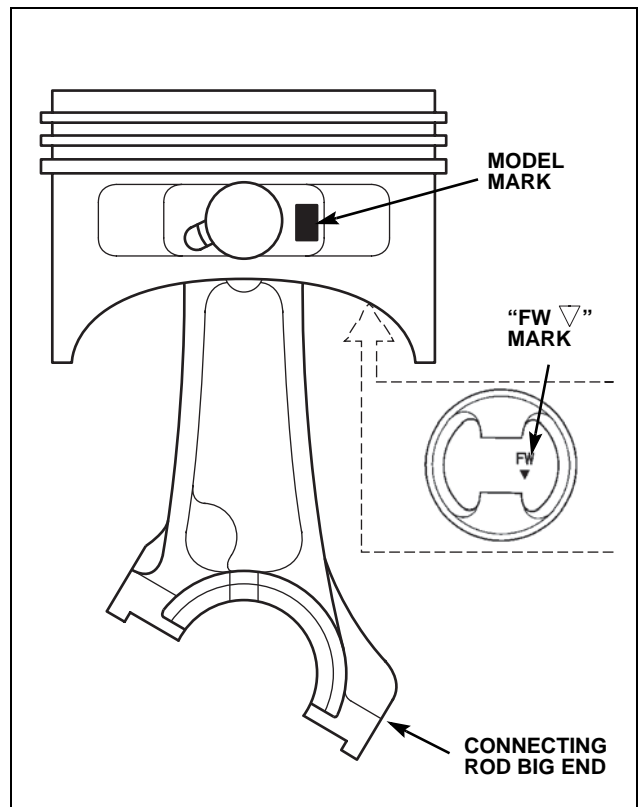

# CAM PULLEY/CRANKSHAFT/ PISTON/CYLINDER BLOCK

## • THRUST WASHER

### INSTALLATION

1. Install the timing belt on the timing pulley.
2. Install the thrust washer; note the installation direction.

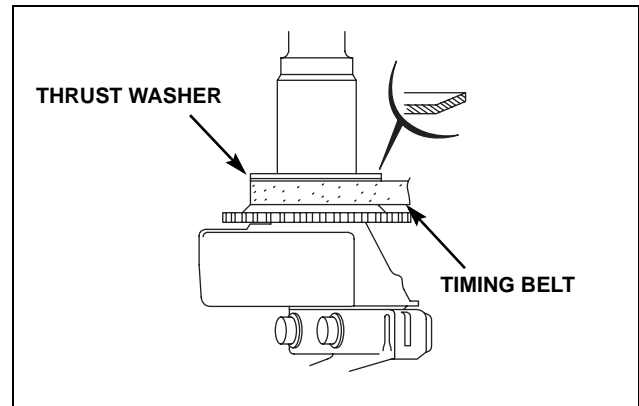

## • CYLINDER BLOCK/6 x 25 mm FLANGE BOLT

### INSTALLATION

1. Align the mark on the cylinder block with the mark on the crankshaft.
2. Install the cam pulley ([P. 8-2](#)).

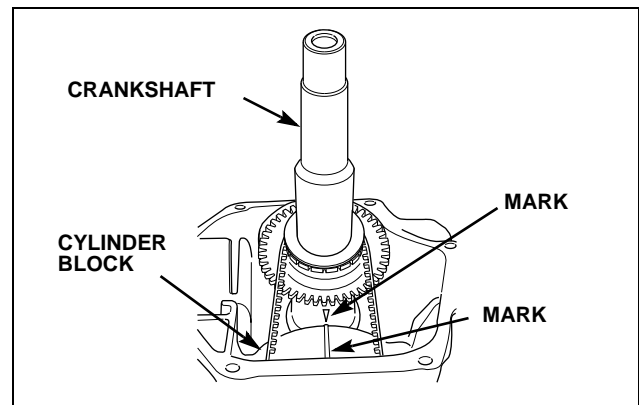

3. Clean the mating surfaces of the cylinder block and the oil pan using a degreasing agent and a clean shop towel.
4. Install the two 8 x 20 mm dowel pins in the cylinder block.
5. Apply a bead (1.5 ~ 2.0 mm [0.06 ~ 0.08 in]) of Hondabond HT liquid gasket (ThreeBond 1216) to the cylinder block.
6. Install the oil pan on the cylinder block. To ease installation, turn the crankshaft to help align the governor gears.

Assemble within 10 minutes after applying the liquid gasket.

7. Install the eight 6 x 25 mm flange bolts until hand tight; then tighten to the specified torque in the numbered sequence shown.

**TORQUE: 12 N•m (8.9 ft-lb)**

8. Wait for approximately 20 minutes after assembly before filling with oil and starting the engine.

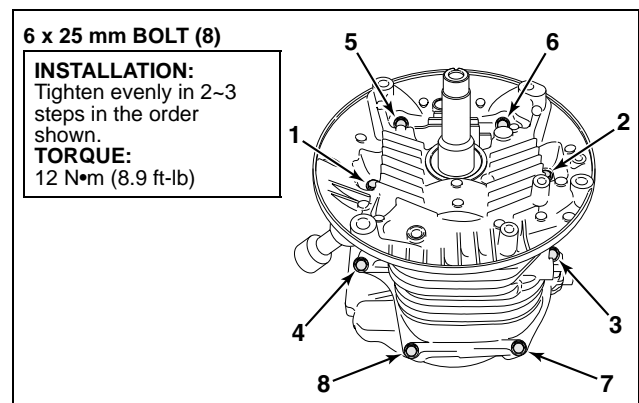
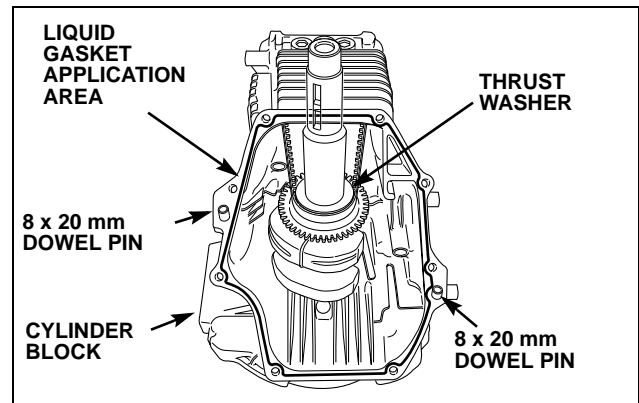

### 3. PISTON

#### DISASSEMBLY/REASSEMBLY

##### PISTON RINGS

**INSPECTION:** [P. 8-14](#)

**REASSEMBLY:**

- Install with the manufacturer's mark facing upward as shown.
- Do not interchange the top ring and second ring.
- After assembly, check for smooth movement of the piston ring.
- Stagger the piston ring end gaps 120° apart.
- Do not align the piston ring end gaps with the piston pin.

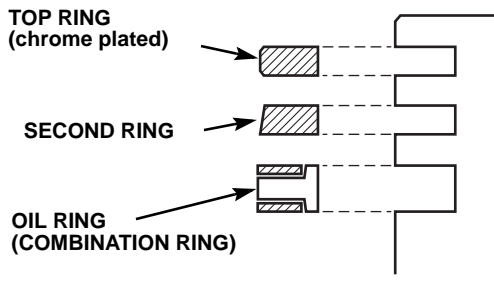

##### TOP RING

**REASSEMBLY:**  
Chrome plated. Do not interchange with the SECOND RING.

MANUFACTURER'S MARK

OIL RING  
(COMBINATION RING)

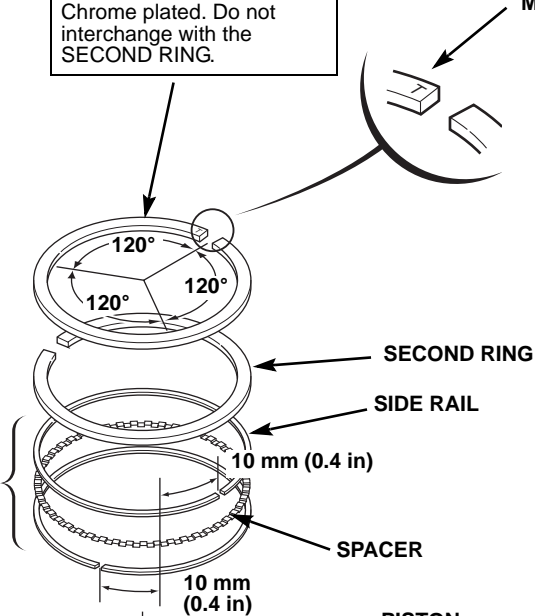

##### PISTON

INSPECTION: [P. 8-13](#), [P. 8-14](#)

MODEL MARK

##### PISTON PIN

INSPECTION: [P. 8-15](#)

##### PISTON PIN CLIP (2)

**REASSEMBLY:**

- Install by setting one end of the clip in the piston groove, holding the other end with a long-nosed pliers, and rotating the clip in.
- Do not align the end gap of the clip with the cutout in the piston pin bore.

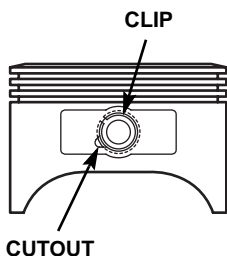

##### CONNECTING ROD

INSPECTION: [P. 8-15](#)  
REASSEMBLY: [P. 8-8](#)

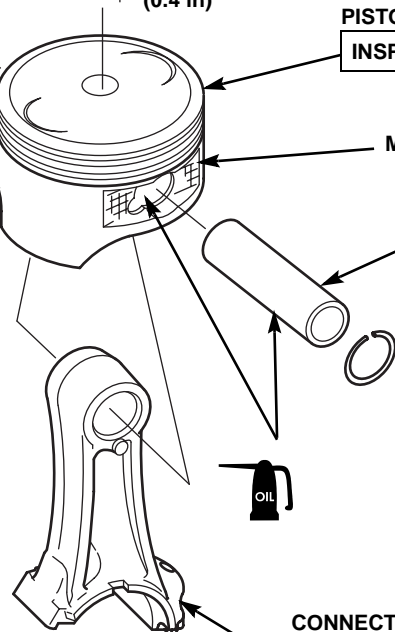

## CAM PULLEY/CRANKSHAFT/ PISTON/CYLINDER BLOCK

### • PISTON/CONNECTING ROD REASSEMBLY

1. Apply clean engine oil to the piston pin bore and the connecting rod small end.
2. Set the piston so that the "FW ▽" mark stamped at the back of the piston points down.
3. Install the connecting rod and piston so that the model mark near the piston pin bore and the longer side of the connecting rod big end are on the right side.
4. Apply clean engine oil to the piston pin, and install the pin into the piston pin bore.
5. Install new piston pin clips.
6. Install the piston/connecting rod assembly into the cylinder block ([P. 8-5](#)).

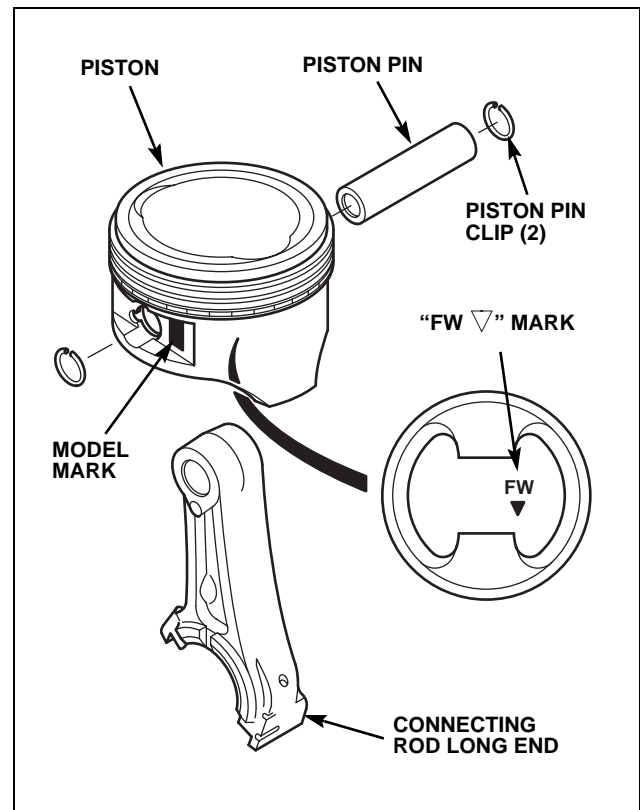

## 4. VALVES

### DISASSEMBLY/REASSEMBLY

#### VALVE SPRING RETAINER (2)

**DISASSEMBLY:**  
Push down and slide the retainer to the side, so the valve stem slips through the hole at the side of the retainer.

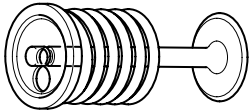

Do not remove the valve spring retainer while the piston is installed, or the valve will drop into the cylinder.



#### VALVE SPRING (2)

**INSPECTION:** [P. 8-18](#)

#### VALVE STEM SEAL

Intake only. Do not reuse.

#### SPARK PLUG

**INSPECTION:** [P. 3-9](#)

**Standard spark plug:**

Pressure washer applications:

BPR6ES (NGK)

All others:

BPR5ES (NGK)

#### VALVE GUIDE

**INSPECTION:** [P. 8-19](#)

#### CYLINDER BLOCK

**CLEANING:** [P. 8-11](#)

#### EXHAUST VALVE

##### REASSEMBLY:

- Before installation, remove carbon deposits and inspect the valve.
- Do not interchange with the intake valve.

##### VALVE HEAD DIAMETER

IN: 25 mm (0.98 in)

EX: 24 mm (0.94 in)

**INSPECTION:** [P. 8-19](#)

#### INTAKE VALVE

##### REASSEMBLY:

- Before installation, remove carbon deposits and inspect the valve.
- Do not interchange with the exhaust valve.
- Be careful not to damage the valve stem seal when installing.

**INSPECTION:** [P. 8-19](#)

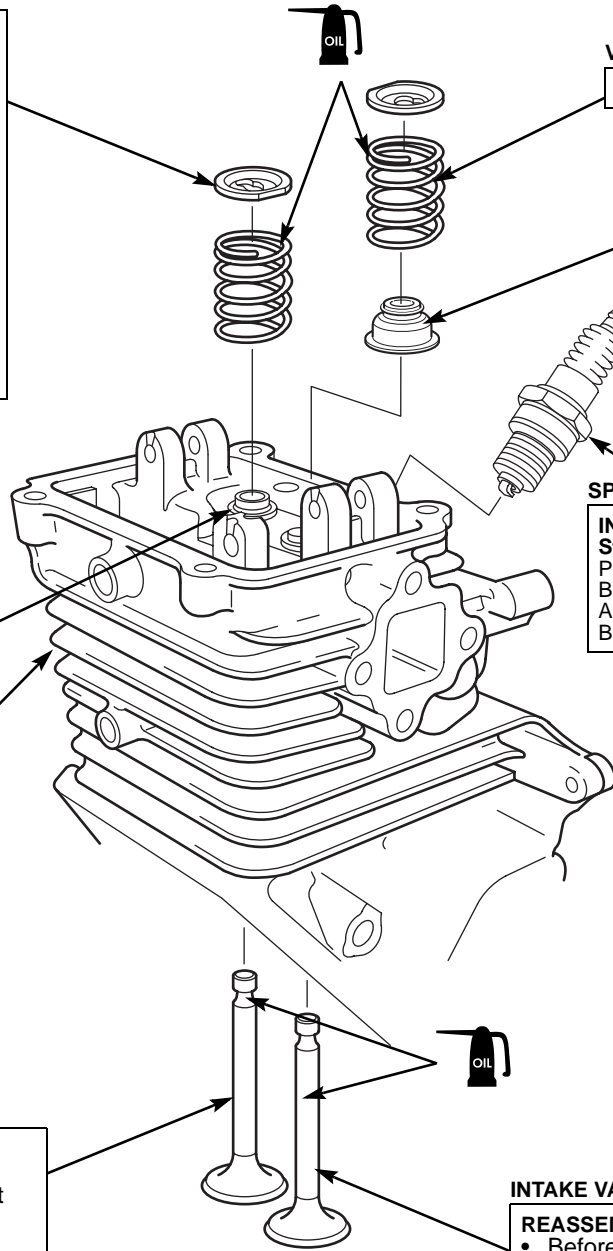

## CAM PULLEY/CRANKSHAFT/ PISTON/CYLINDER BLOCK

---

### • CYLINDER BLOCK

#### COMBUSTION CHAMBER CLEANING

1. Prepare a thick paper cylinder or equivalent material with a large enough diameter to fit against the cylinder wall of the cylinder block.
2. Insert the thick paper into the cylinder to protect the cylinder wall during combustion chamber cleaning.
3. Attach a commercially available combustion cleaning brush to an electric drill, and clean the combustion chamber.

Do not press hard against the cleaning brush during combustion chamber cleaning.

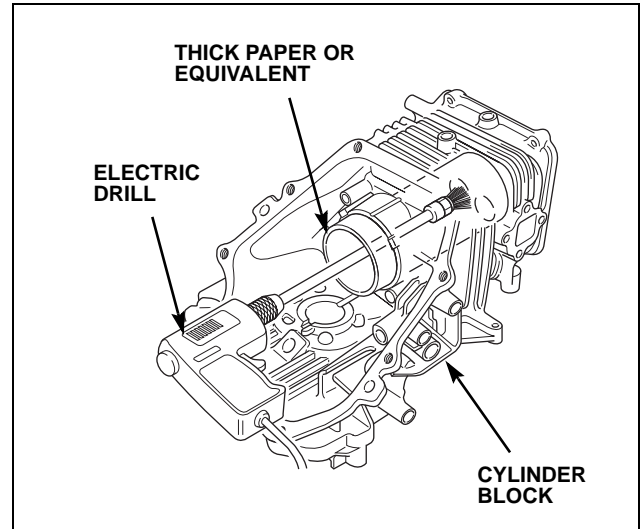

**5. GOVERNOR**

**DISASSEMBLY/REASSEMBLY**

**GOVERNOR WEIGHT HOLDER ASSEMBLY**

**REASSEMBLY:**  
Before installing, check for wear and damage of the gear.  
Check that the weight moves freely.  
Be sure to install the governor weight before installing the crankshaft.

**GOVERNOR SLIDER**

**REASSEMBLY:**  
Slide the governor weights to install the slider; then check to be sure the slider moves smoothly.

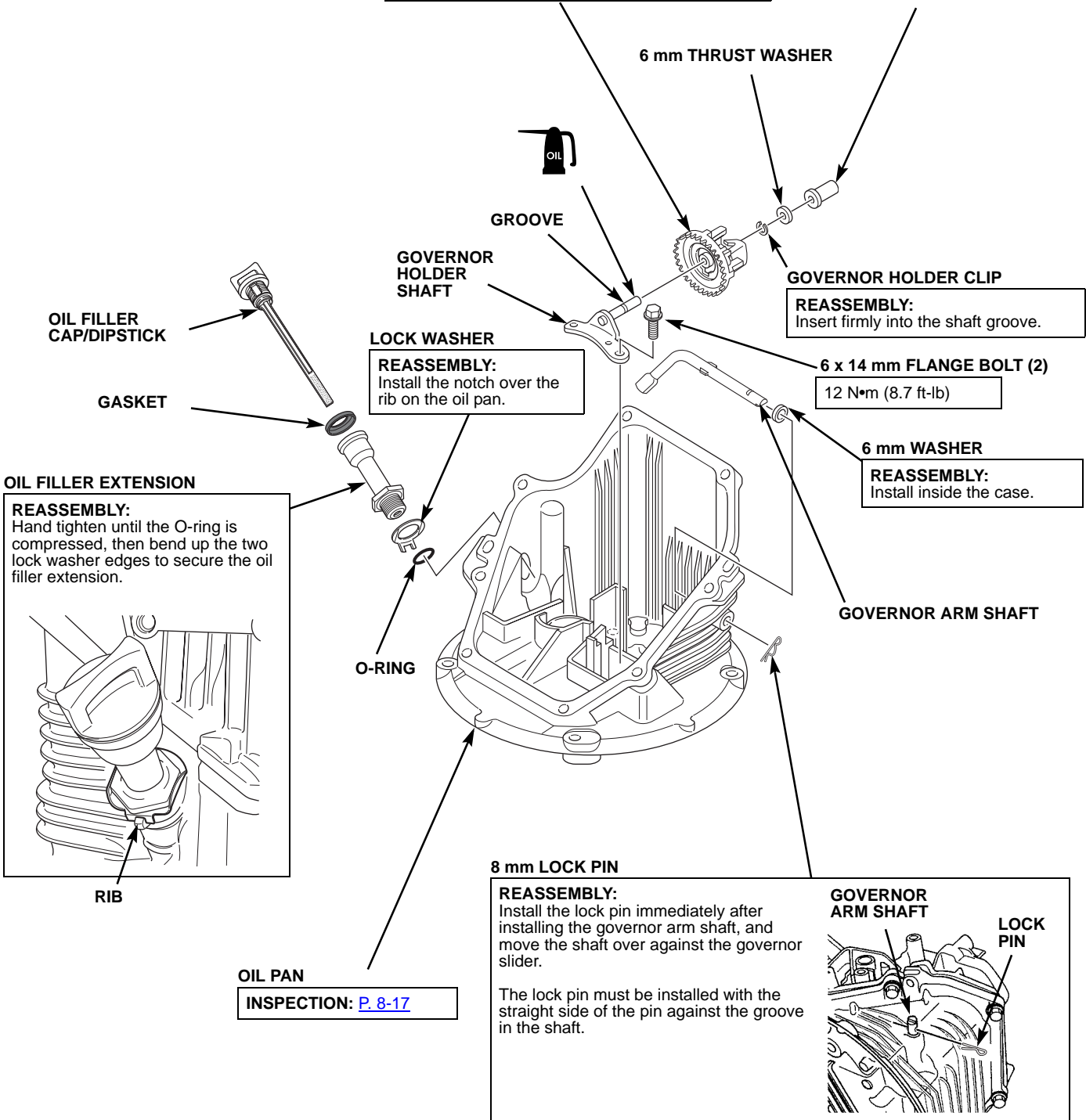



# CAM PULLEY/CRANKSHAFT/ PISTON/CYLINDER BLOCK

## INSPECTION

### • CAM LOBE HEIGHT

Standard	Service limit
37.394 mm (1.4722 in)	37.369 mm (1.4712 in)

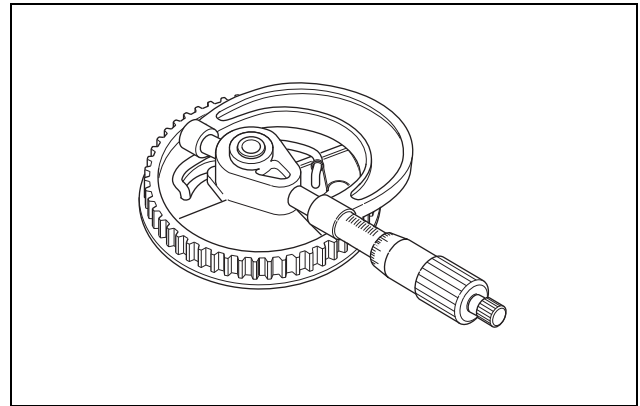

### • CAM PULLEY ID (BEARING)

Standard	Service limit
10.027 mm (0.3948 in)	10.075 mm (0.3967 in)

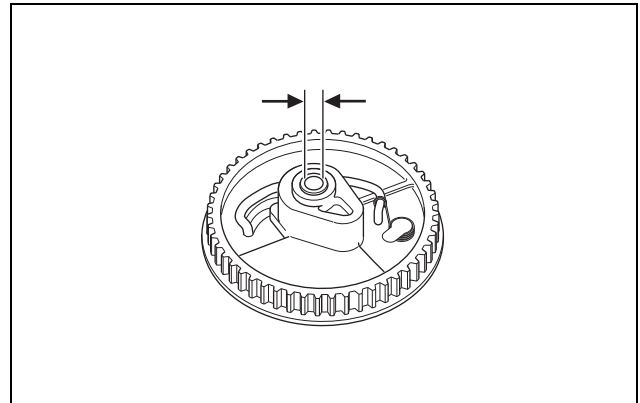

### • CAM PULLEY SHAFT OD

Standard	Service limit
9.987 mm (0.3932 in)	9.920 mm (0.3906 in)

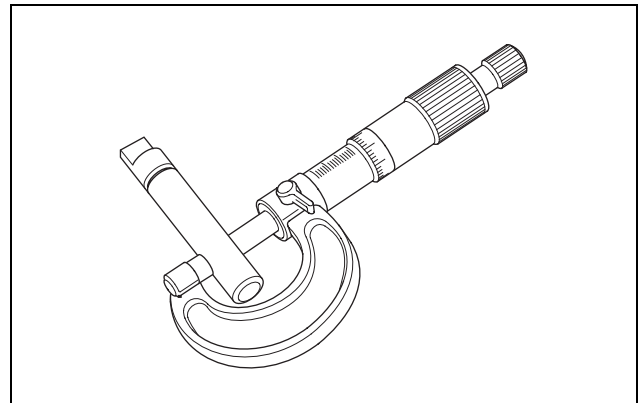

### • ROCKER ARM ID

Standard	Service limit
6.000 mm (0.2362 in)	6.043 mm (0.2379 in)

### • ROCKER ARM SHAFT BEARING ID

Standard	Service limit
6.000 mm (0.2362 in)	6.043 mm (0.2379 in)

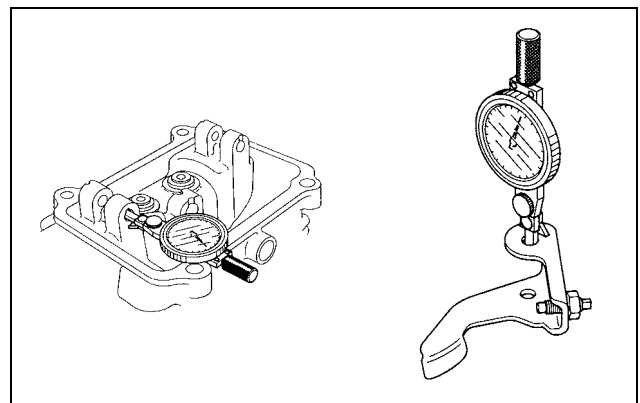

• **ROCKER ARM SHAFT OD**

Standard	Service limit
5.990 mm (0.2358 in)	5.953 mm (0.2344 in)

• **ROCKER ARM SHAFT BEARING-TO-ROCKER ARM SHAFT CLEARANCE**

Standard	Service limit
0.010 – 0.058 mm (0.004 – 0.0023 in)	0.07 mm (0.003 in)

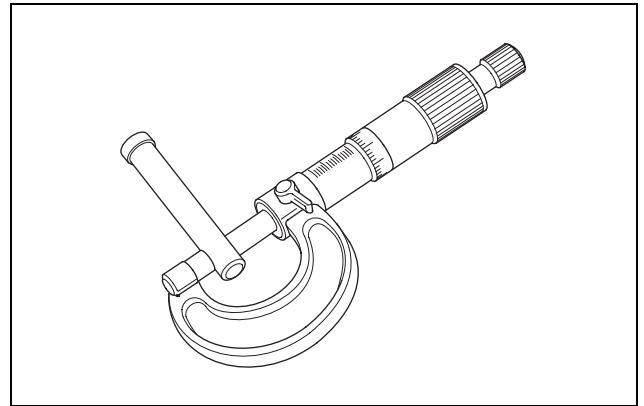

• **CYLINDER ID**

Measure and record the cylinder ID at three levels in both the “X” axis (perpendicular to the crankshaft) and the “Y” axis. Take the maximum reading to determine the cylinder wear and taper. GCV135/GCV160

Standard	Service limit
64.000 mm (2.52 in)	64.165 mm (2.5262 in)

GCV190/GSV190

Standard	Service limit
69.000 mm (2.7165 in)	69.165 mm (2.7230 in)

If the cylinder I.D. is worn beyond the service limit, it must be replaced. Do not hone the cylinder.

• **PISTON SKIRT OD**

Measure and record the piston OD at a point 10 mm (0.4 in) from the bottom of the skirt and 90° to the piston pin bore.

GCV135/GCV160

Standard	Service limit
63.969 mm (2.5185 in)	63.829 mm(2.5129 in)

GCV190/GSV190

Standard	Service limit
69.000 mm (2.7165 in)	69.165 mm (2.7230 in)

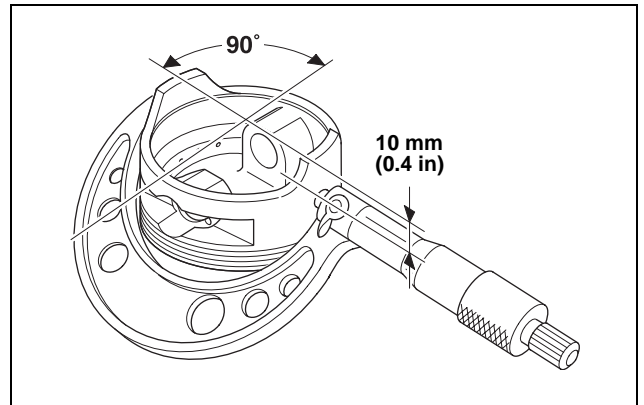
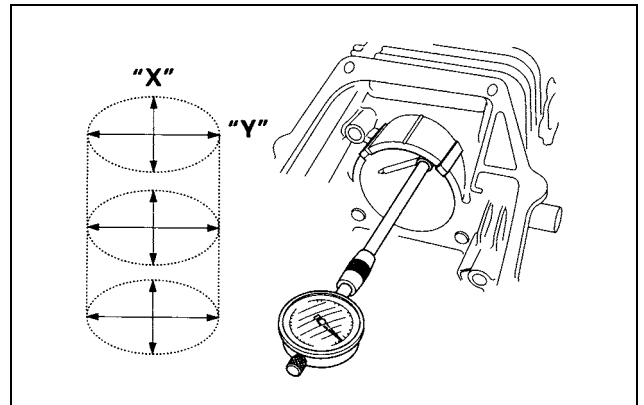

• **PISTON-TO-CYLINDER CLEARANCE**

GCV135/GCV160

Standard	Service limit
0.031 ~ 0.070 mm (0.0012 ~ 0.0028 in)	0.12 mm(0.005 in)

GCV190/GSV190

Standard	Service limit
0.015 ~ 0.054 mm (0.00059 ~ 0.0020 in)	0.12 mm (0.005 in)

# CAM PULLEY/CRANKSHAFT/ PISTON/CYLINDER BLOCK

## • PISTON RING WIDTH WITH NON-TETHERED GAS CAP

	Standard	Service limit
Top/Second	1.5 mm (0.06 in)	1.37 mm (0.054 in)
Oil (1-piece type)	2.5 mm (0.10 in)	2.37 mm (0.093 in)

## WITH TETHERED EVAPORATIVE GAS CAP

	Standard	Service limit
Top (GCV160)	0.93 ~ 0.95 mm (0.036 ~ 0.037 in)	0.91 mm (0.035 in)
Top (GCV/ GSV190)	0.95 ~ 0.97 mm (0.037 ~ 0.038 in)	0.93 mm (0.036 in)
Second	0.97 ~ 0.99 mm (0.038 ~ 0.039 in)	0.95 mm (0.037 in)

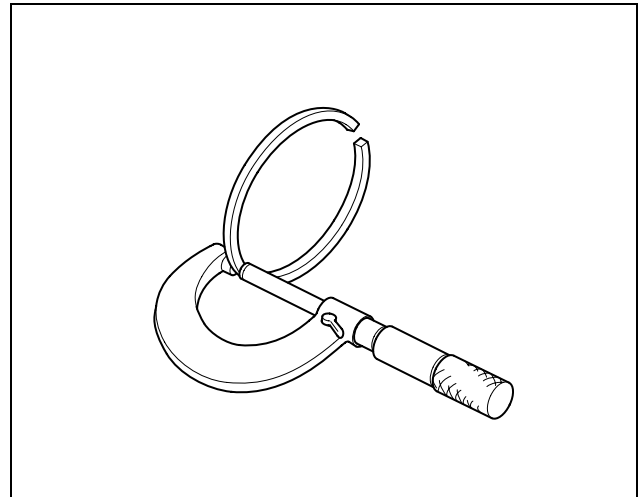

Do not hone the cylinder when installing new piston rings.

## • PISTON RING SIDE CLEARANCE WITH NON-TETHERED GAS CAP

	Standard	Service limit
Top	0.035 ~ 0.065 mm (0.0013 ~ 0.0026 in)	0.15 mm (0.006 in)
Second	0.015 ~ 0.049 mm (0.0006 ~ 0.0019 in)	0.15 mm (0.006 in)

## WITH TETHERED EVAPORATIVE GAS CAP

	Standard	Service limit
Top (GCV160)	0.055 ~ 0.089 mm (0.002 ~ 0.004 in)	0.150 mm (0.006 in)
Top (GCV/ GSV190)	0.035 ~ 0.069 mm (0.001 ~ 0.003 in)	0.150 mm (0.006 in)
Second	0.015 ~ 0.049 mm (0.0006 ~ 0.0019 in)	0.15 mm (0.006 in)

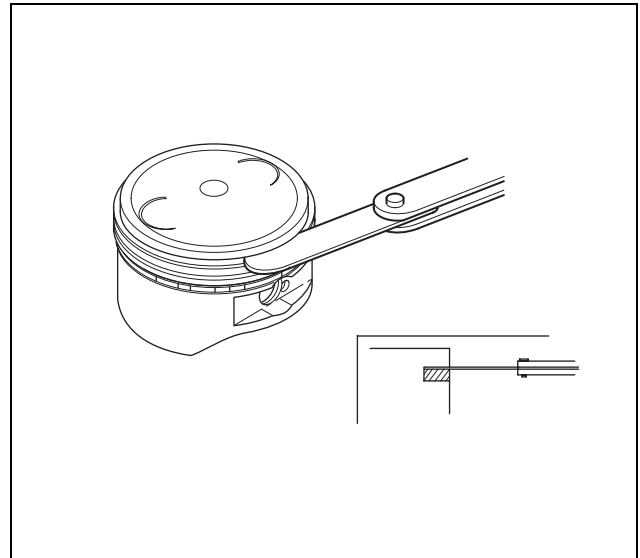

## • PISTON RING END GAP WITH NON-TETHERED GAS CAP

	Standard	Service limit
Top	0.20 ~ 0.35 mm (0.008 ~ 0.014 in)	1.0 mm (0.04 in)
Second	0.30 ~ 0.45 mm (0.012 ~ 0.018 in)	1.0 mm (0.04 in)

## WITH TETHERED EVAPORATIVE GAS CAP

	Standard	Service limit
Top	0.20 ~ 0.35 mm (0.008 ~ 0.014 in)	1.0 mm (0.04 in)
Second	0.35 ~ 0.50 mm (0.014 ~ 0.020 in)	1.0 mm (0.04 in)
Oil ring	0.20 ~ 0.70 mm (0.008 ~ 0.030 in)	1.0 mm (0.04 in)

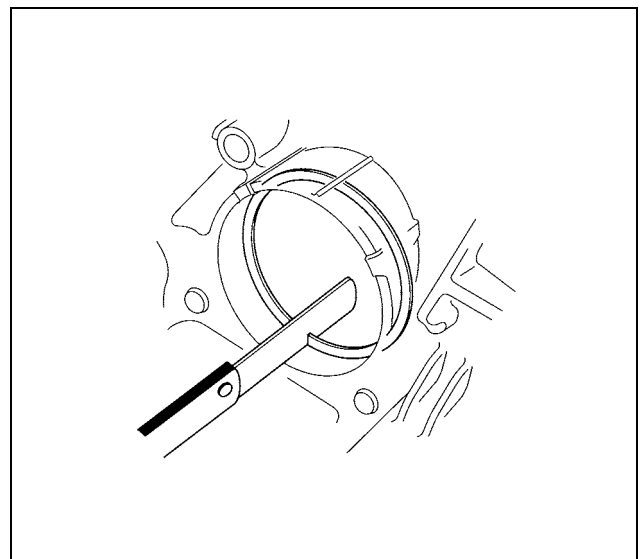

Use the top of the piston to position the ring horizontally in the cylinder.

# CAM PULLEY/CRANKSHAFT/ PISTON/CYLINDER BLOCK

## • PISTON PIN OD

Standard	Service limit
13.000 mm (0.5118 in)	12.954 mm (0.5100 in)

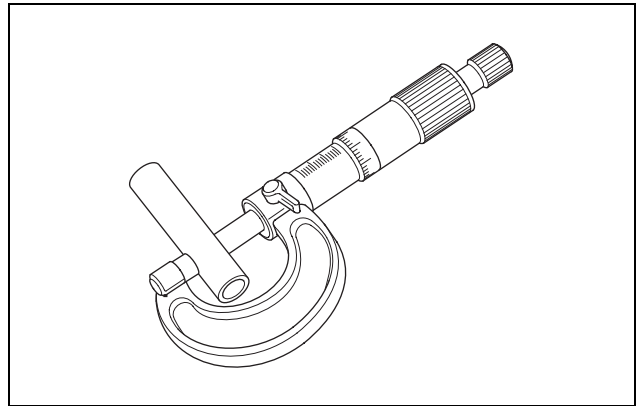

## • PISTON PIN BORE ID

Standard	Service limit
13.002 mm (0.5119 in)	13.048 mm (0.5137 in)

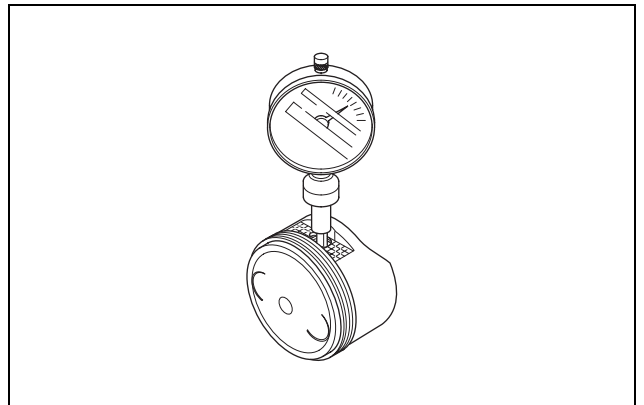

## • CONNECTING ROD SMALL END ID

Standard	Service limit
13.005 mm (0.5120 in)	13.07 mm (0.515 in)

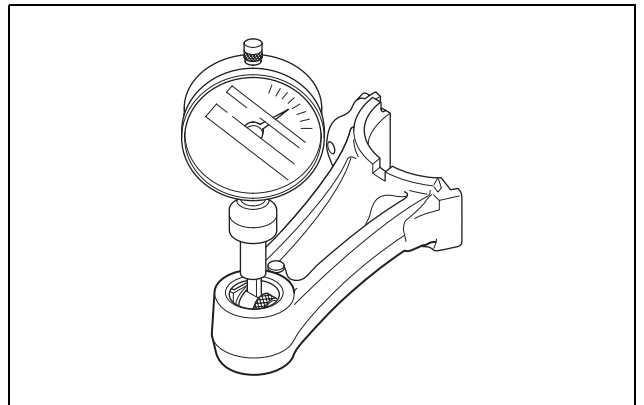

## • CONNECTING ROD BIG END ID

Standard	Service limit
30.02 mm (1.1819 in)	30.066 mm (1.1837 in)

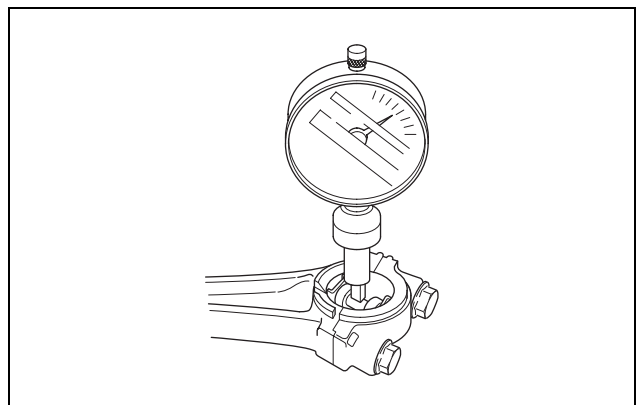

# CAM PULLEY/CRANKSHAFT/ PISTON/CYLINDER BLOCK

## • CRANKSHAFT MAIN JOURNAL OD

	Standard	Service limit
PTO side	27.993 mm (1.1021 in)	27.933 mm (1.0997 in)
Flywheel side	25.393 mm (0.9997 in)	25.333 mm (0.9974 in)

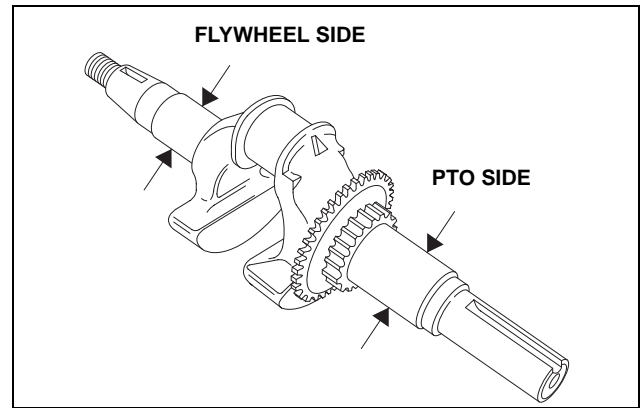

## • CRANK PIN OD

Standard	Service limit
29.980 mm (1.1803 in)	29.92 mm (1.1780 in)

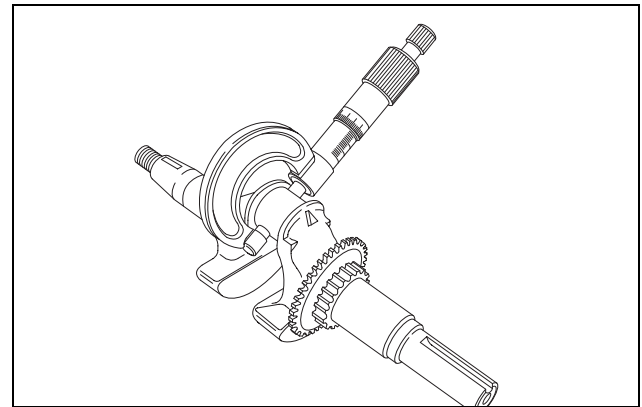

## • CONNECTING ROD BIG END AXIAL CLEARANCE

Measure the clearances with a feeler gauge.

Standard	Service limit
0.1 ~ 0.4 mm (0.004 ~ 0.016 in)	0.8 mm (0.031 in)

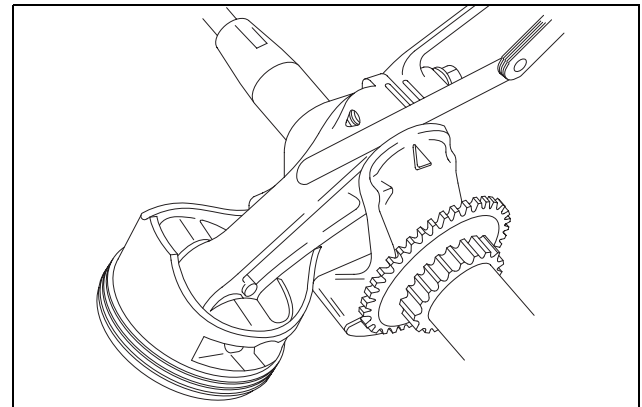

## CAM PULLEY/CRANKSHAFT/ PISTON/CYLINDER BLOCK

### • CONNECTING ROD BIG END OIL CLEARANCE

1. Wipe oil off the crank pin and connecting rod bearing mating surface.
2. Place plastigauge on the crankpin axially. Install the connecting rod and cap. Tighten the connecting rod bolts equally to the specified torque, while holding the crankshaft to keep it from turning.

**TORQUE: 12 N•m (8.9 ft-lb)**

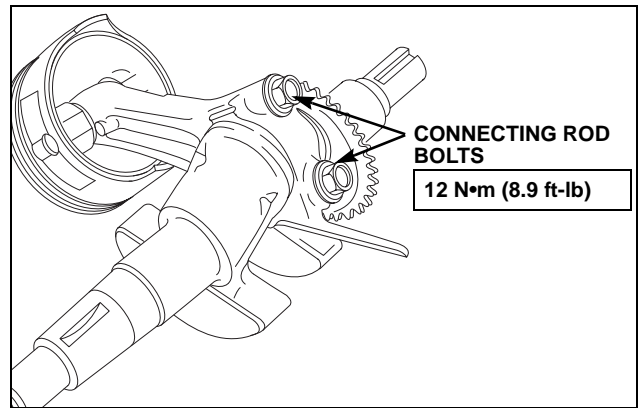

3. Remove the connecting rod cap and measure the plastigauge with the scale provided.

Standard oil clearance	Service limit
0.040 ~ 0.063 mm (0.0016 ~ 0.0025 in)	0.12 mm (0.005 in)

4. If the clearance exceeds the service limit, replace the connecting rod and recheck the clearance.

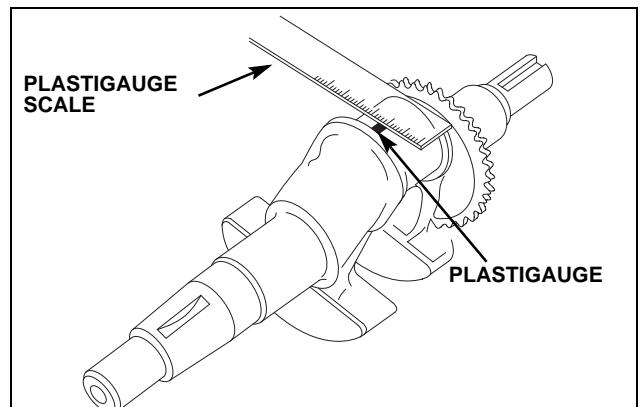

### • CYLINDER BLOCK MAIN JOURNAL ID

Standard	Service limit
25.420 mm (1.008 in)	25.466 mm (1.0026 in)

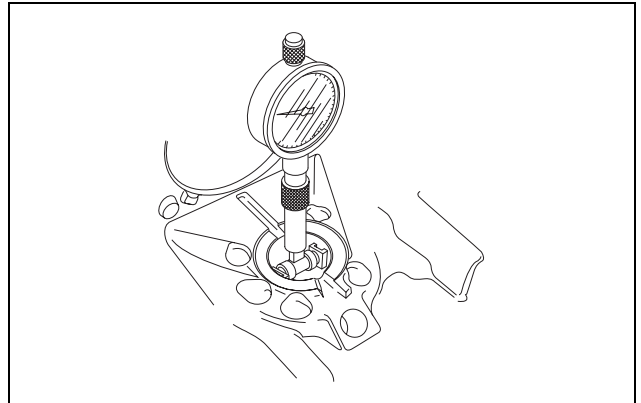

### • OIL PAN MAIN JOURNAL ID

Standard	Service limit
28.020 mm (1.1031 in)	28.066 mm (1.1050 in)

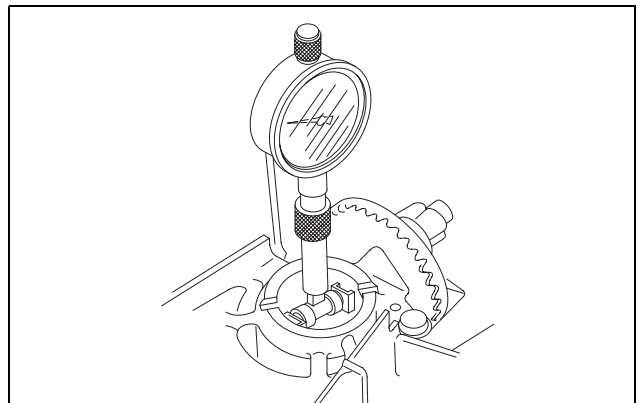

## CAM PULLEY/CRANKSHAFT/ PISTON/CYLINDER BLOCK

### • CRANKSHAFT AXIAL CLEARANCE

Measure the crankshaft axial play before removing the oil pan, crankshaft, and piston.

Standard	Service limit
0.15 ~ 0.75 mm (0.006 ~ 0.030 in)	1.0 mm (0.04 in)

Replace the crankshaft if the measurement is above the service limit.

Install the new crankshaft and recheck the axial clearance. If it exceeds the service limit, replace the oil pan and cylinder block.

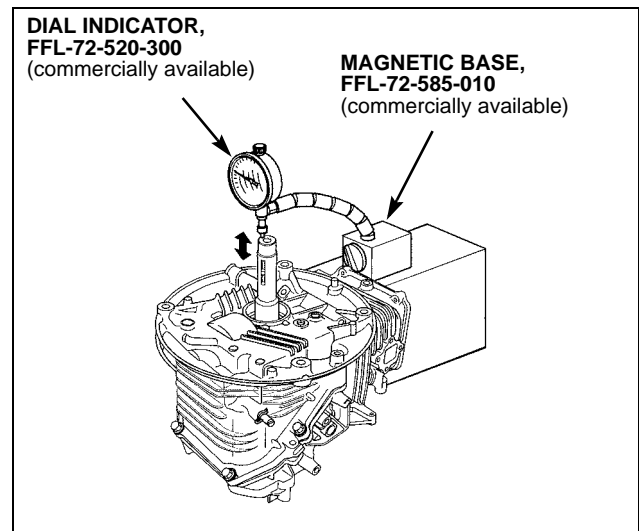

### • CRANKSHAFT RUNOUT

Measure the crankshaft runout before removing the oil pan, crankshaft, and piston. Do not allow the dial indicator tip to fall into the keyway groove.

Crankshaft runout	Service limit
	0.20 mm (0.008 in)

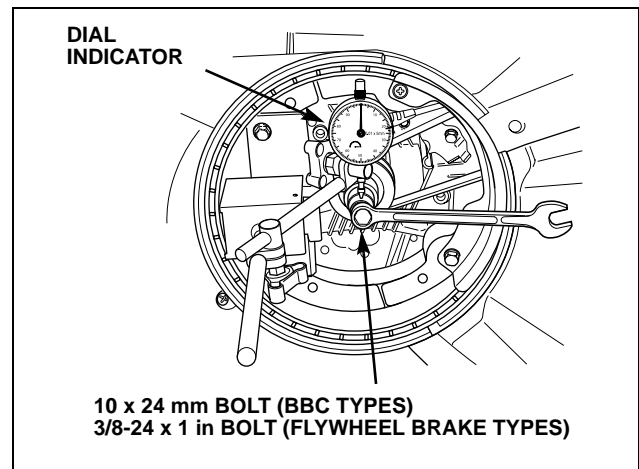

### • VALVE SPRING FREE LENGTH

Measure the free length of the valve springs.

Standard	Service limit
30.5 mm (1.20 in)	29.0 mm (1.14 in)

Replace the springs if they are shorter than the service limit.

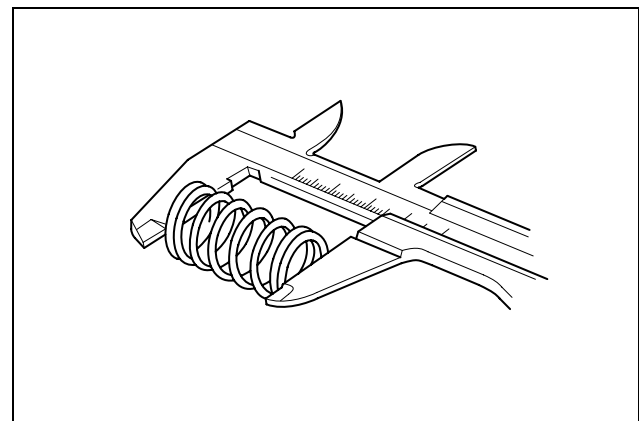

## • VALVE FACE/STEM OD

Inspect each valve face for pitting or wear irregularities. Inspect each valve stem for bending or abnormal stem wear. Replace the valve if necessary.

Measure and record each valve stem OD.

	Standard	Service limit
IN	5.48 mm (0.216 in)	5.318 mm (0.2094 in)
EX	5.44 mm (0.214 in)	5.275 mm (0.2077 in)

Replace the valves if their OD is smaller than the service limit.

## • VALVE GUIDE ID

Measure and record each valve guide ID.

Standard	Service limit
5.50 mm (0.217 in)	5.572 mm (0.2194 in)

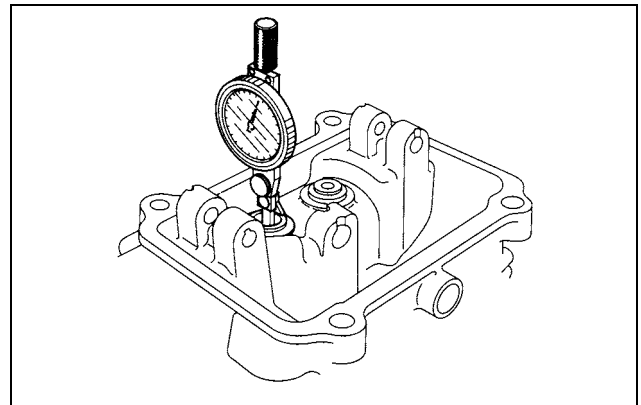
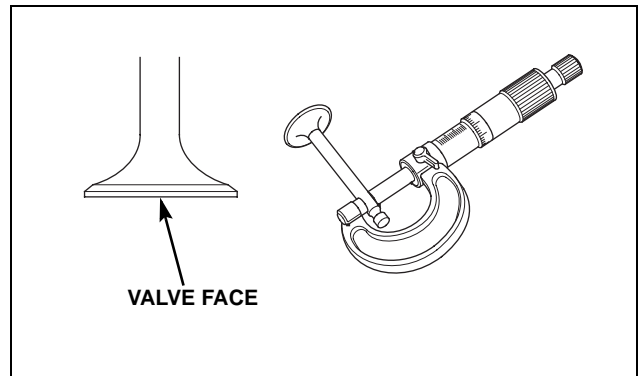

## • VALVE SEAT WIDTH

1. Thoroughly clean and remove any carbon deposits from the combustion chamber, valve seats, and valve faces ([P. 8-11](#)).
2. Apply Prussian Blue or erasable felt-tipped marker ink to the valve faces.
3. Insert the valves into the cylinder block; then lift and snap them closed against their seats several times. Be sure the valves do not rotate in their seats.

Transferred marking compound will show any area of the valve seat that is not concentric and may require valve seat reconditioning.

4. Measure the valve seat width.

Standard	Service limit
0.7 mm (0.028 in)	1.8 mm (0.07 in)

Replace the cylinder block if the valve seat width is over the service limit.

5. Recondition valve seats if the valve seat width is under the standard or if they are pitted and/or damaged ([P. 8-20](#)).

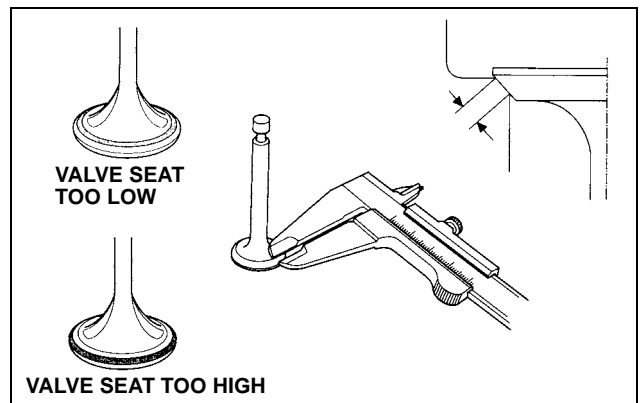
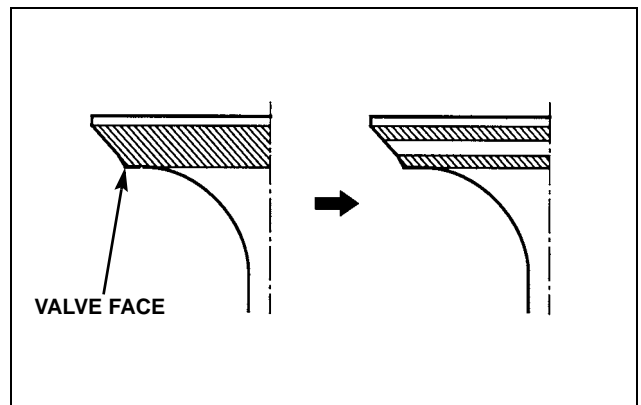



## 6. VALVE SEAT RECONDITIONING

1. Thoroughly clean and remove any carbon deposits from the combustion chamber, valve seats, and valve faces (P. 8-11).
2. Apply Prussian Blue or erasable felt-tipped marker ink to the valve faces.
3. Insert the valves into the cylinder block; then lift and snap them closed against their seats several times. Be sure the valves do not rotate in their seats.

Transferred marking compound will show any area of the valve seat that is not concentric and may require valve seat reconditioning

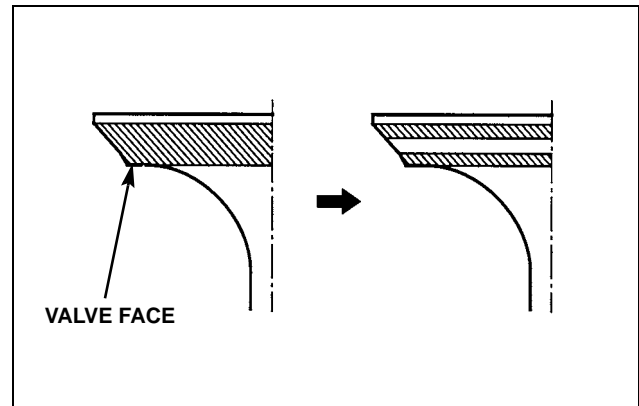

### VALVE SEAT RECONDITIONING TOOLS

(commercially available)

SOLID PILOT BAR, 5.50 mm (NWX PM 100055SH)

SOLID PILOT BAR, 5.51 mm (NWX PM 100552S)

VALVE SEAT CUTTER #115, 31° (NWX CU 115)

VALVE SEAT CUTTER #122, 45° (NWX CU 122)

VALVE SEAT CUTTER #111, 60° (NWX CU 111)

T-WRENCH #505 (NWX TW #503-1)

T-WRENCH ADAPTOR (NWX TW 503-1)

ACCESSORY PACKAGE (NWX TW #246)

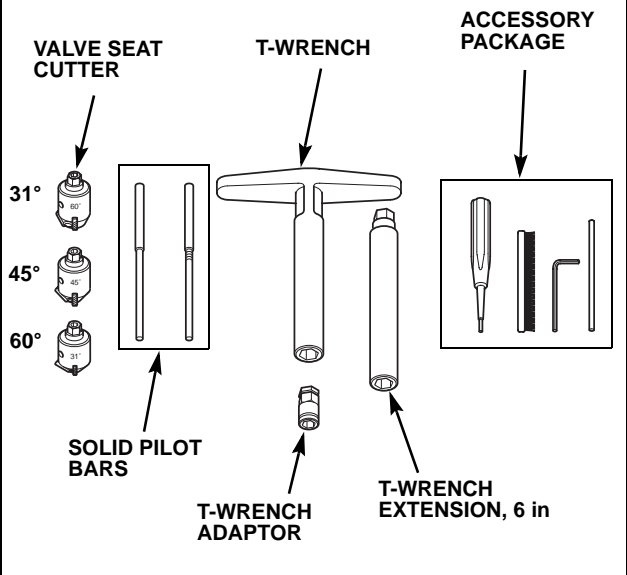

4. Prepare a thick paper cylinder or equivalent material with a large enough diameter to fit against the cylinder wall of the cylinder block.
5. Insert the thick paper into the cylinder to protect the cylinder wall during valve seat reconditioning.

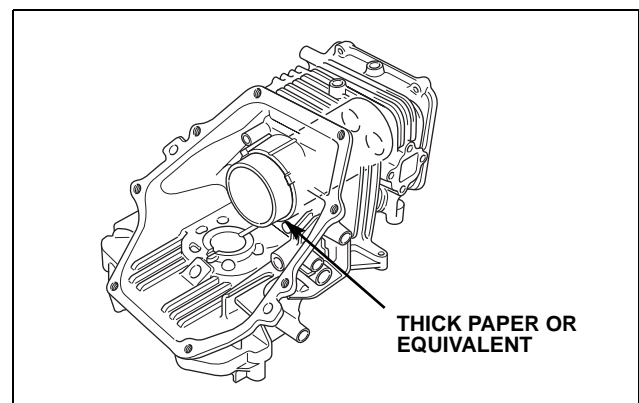

## CAM PULLEY/CRANKSHAFT/ PISTON/CYLINDER BLOCK

- Use the 31° and 60° cutters to narrow and adjust the valve seat so that it contacts the middle of the valve face. The 31° cutter removes material from the top edge. The 60° cutter removes material from the bottom edge. Be sure that the width of the finished valve seat is within specification.

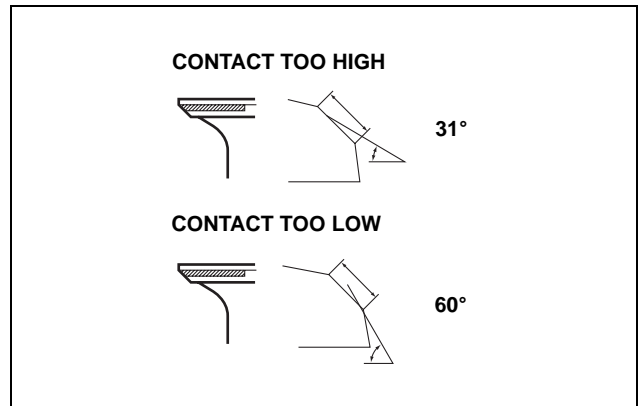

Always turn the cutter clockwise, never counterclockwise. Continue to turn the cutter as you remove it from the valve seat. Always follow the valve seat cutter manufacturer's instructions.

### NOTICE

*Avoid removing excess material from the valve seats. Remove only enough material to clean up the seats, and avoid going over the valve seat width service limit.*

- Make a light pass with the 45° cutter to remove any possible burrs at the edge of the seat.

### • VALVE SEAT WIDTH

Standard	Service limit
0.7 mm (0.028 in)	1.8 mm (0.07 in)

- After resurfacing the seats, inspect for even valve seating. Apply Prussian Blue or erasable felt-tipped marker ink to the valve faces.

Insert the valves into the cylinder block; then lift and snap them closed against their seats several times. Be sure the valves do not rotate in their seats.

The seating surface, as shown by the transferred marking compound, should have a good contact all the way around the valve face.

- Lap the valves into their seats using a 4 mm tube and some commercially available lapping compound.

### NOTICE

*To avoid severe engine damage, be sure to remove all lapping compound from the cylinder block before assembly.*

- Check the valve clearance after reassembly ([P. 3-11](#)).

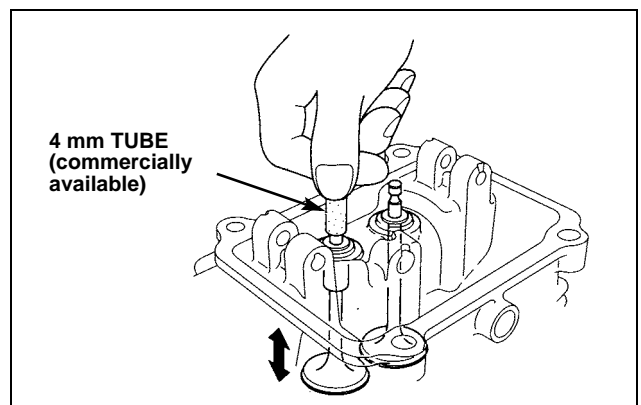
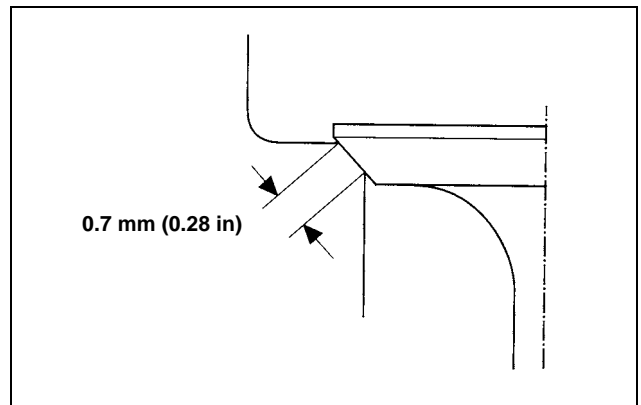
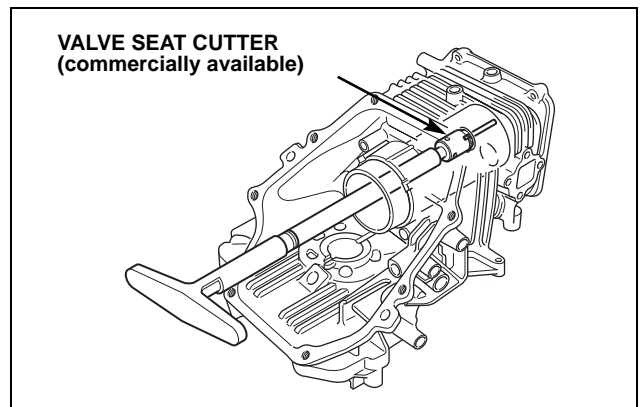

**CAM PULLEY/CRANKSHAFT/  
PISTON/CYLINDER BLOCK**

---

# 9. BBC (BLADE BRAKE/CLUTCH)

1. BBC (BLADE BRAKE/CLUTCH). . . . . 1-1

## 1. BBC (BLADE BRAKE/CLUTCH)

### REMOVAL/INSTALLATION

1. Remove the blade.
2. Remove the blade control inner cable (OEM supplied) from the blade brake/clutch.
3. Remove the brake spring (OEM supplied). Avoid damaging the spring when removing.
4. Release drive belt tension by removing the drive belt from the transmission driven pulley.
5. Remove the recoil starter. Hold the flywheel nut and remove the 10 x 24 mm hex bolt. Remove the blade holder, clutch spring, and driven disk.
6. Rotate the crankshaft so the keyway is up; then remove the drive disk.
7. Slide the brake assembly, including the drive pulley, off the crankshaft.
8. Remove the woodruff key from the outer groove.

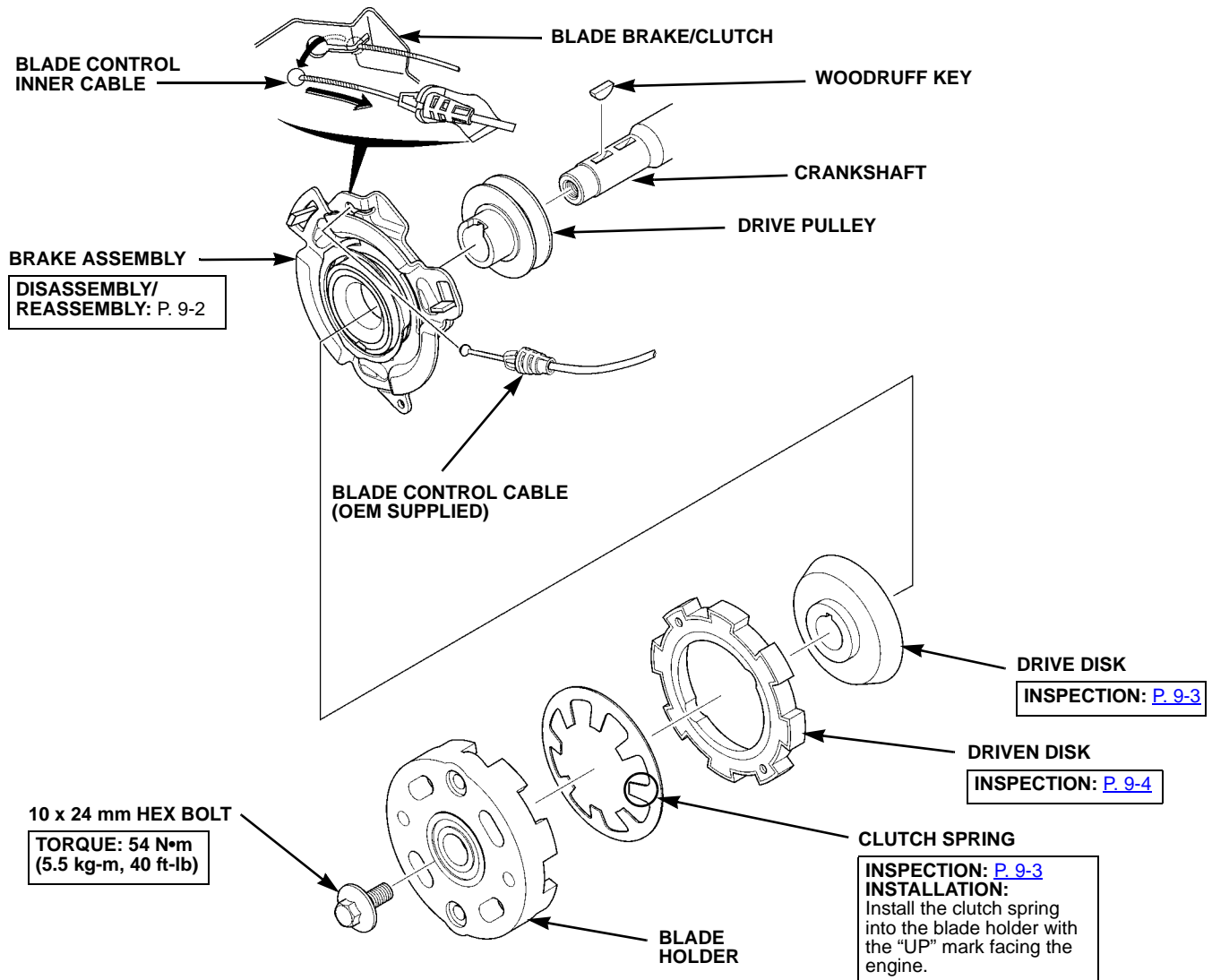

## BBC (BLADE BRAKE/CLUTCH)

### DISASSEMBLY/REASSEMBLY

#### Brake Assembly

1. Push the spring hook plate down.
2. Rotate the spring hook plate clockwise.
3. Release the three hooks, and remove the spring hook plate and ball plate spring.

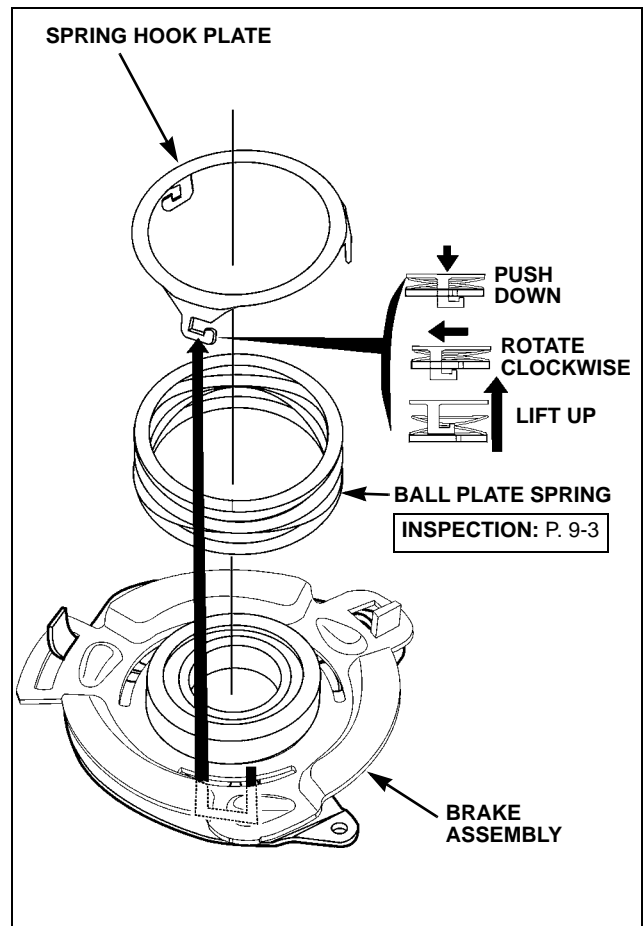

4. Separate the brake plate from the ball plate and remove the three balls.  
Inspect the ball recesses in both the brake plate and ball plate for wear. Replace if necessary.

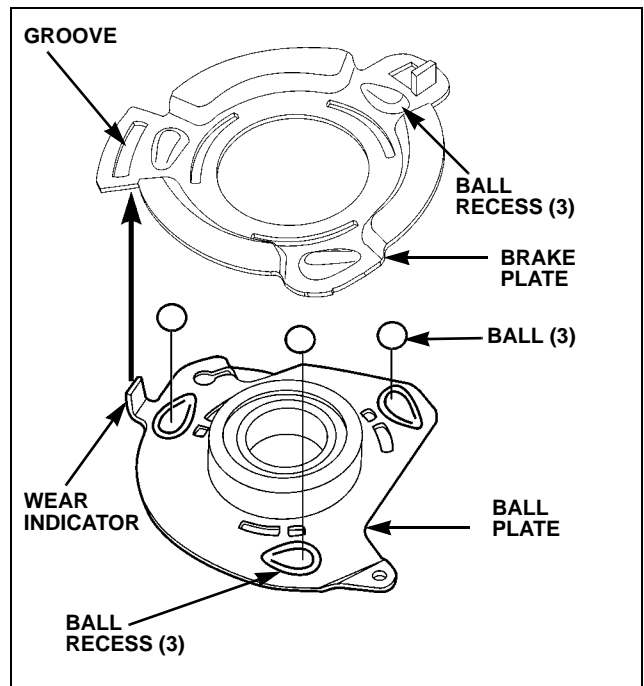

## INSPECTION

### Ball Plate Spring

Inspect the ball plate spring for damage or deformation such as bending, cracks, etc.

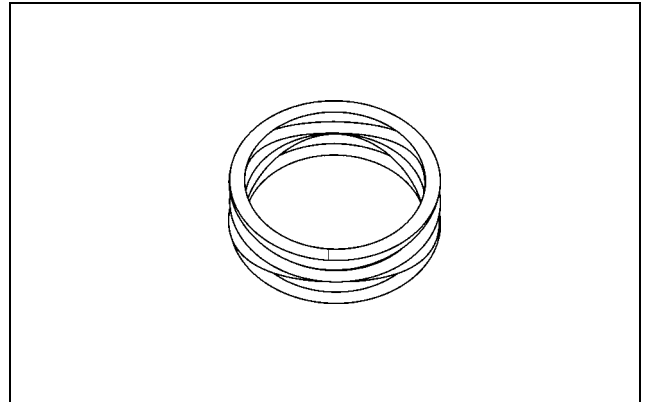

### Clutch Spring

1. Measure the clutch spring free-standing height.

Service Limit
6.8 mm (0.27 in)

2. Replace the spring if it's worn, cracked, or measures less than the service limit.

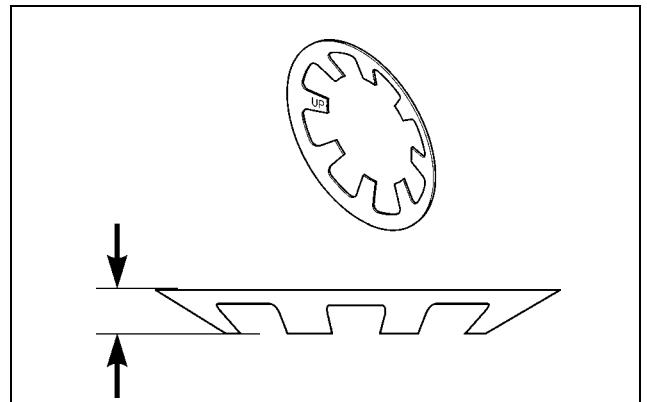

### Drive Disk

Inspect the drive disk for discoloration from overheating and excess wear. Replace if necessary.

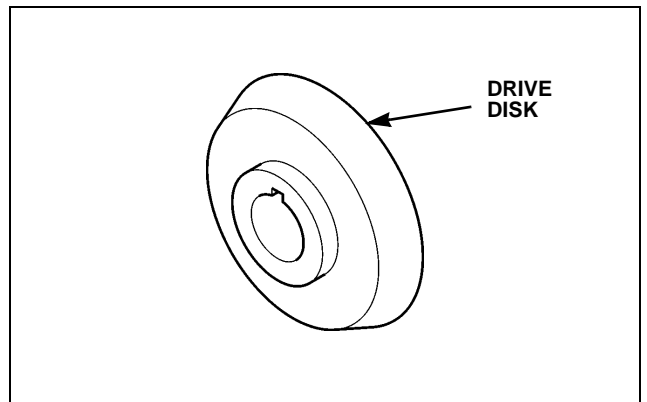

## BBC (BLADE BRAKE/CLUTCH)

---

### Driven Disk

1. Clean the driven disk clutch and brake surface with a clean dry shop towel.
2. Inspect for wear. Replace the driven disk if the drive disk is being replaced.
3. Replace the driven disk if it has been contaminated with oil.

#### **NOTICE**

*Do not put the driven disk into the parts cleaner. If the driven disk is washed with parts cleaner, the driven disk will require replacement.*

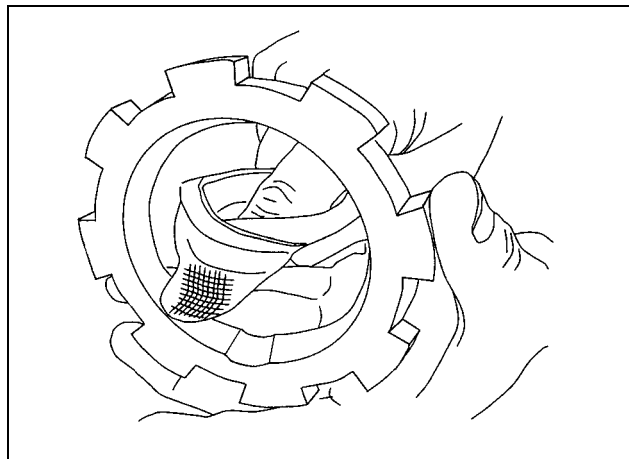

### Ball Bearings

1. Inspect the blade holder bearing and ball plate bearing.
2. Rotate and check each bearing for smooth operation.
3. Replace if binding or rough operation is detected.

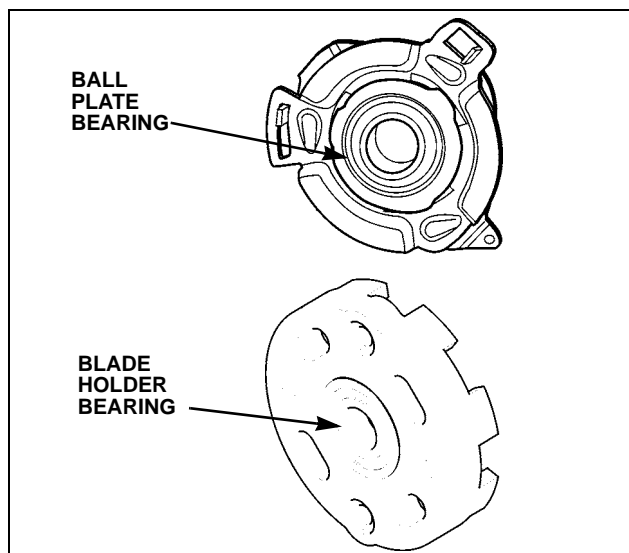

# 10. OPERATION

1. ACS (AUTO CHOKE SYSTEM) . . . . .	10-1	4. FUEL TANK CAP . . . . .	10-5
2. ARCS (AUTO RETURN CHOKE SYSTEM) . . . . .	10-2	5. AUTO THROTTLE® . . . . .	10-6
3. ROTO-STOP® MECHANISM. . . . .	10-3		

## 1. ACS (AUTO CHOKE SYSTEM)

Certain GCV160/190 engine types use Honda's fully Automatic Choke System or ACS. Most engines are equipped with a manual choke system that requires the operator to set it before starting the engine and release it after the engine starts.

### PRINCIPLE OF OPERATION

The system opens and closes the choke using a small cup filled with temperature sensitive wax.

The choke control assembly senses the engine block temperature.

When the engine is cold, the wax is a condensed solid and the choke spring pulls the choke closed.

When the engine is started and begins to warm up, the wax begins to expand, forcing the plunger out. As the plunger moves out, the choke rod is moved in the same direction, turning the choke arm. The choke arm rotates the choke lever, opening the carburetor choke valve.

At 104 degrees Fahrenheit, the wax in the choke control assembly is fully expanded, and the choke is completely open.

After you turn off the engine, the wax contracts, and the ACS spring pushes the plunger into the wax cup, closing the choke for the next cold start.

The choke spring allows the choke valve to "flutter" while the engine is warming up. This allows the engine to be operated before the choke is fully open and prevents an over-rich running condition during warm up.

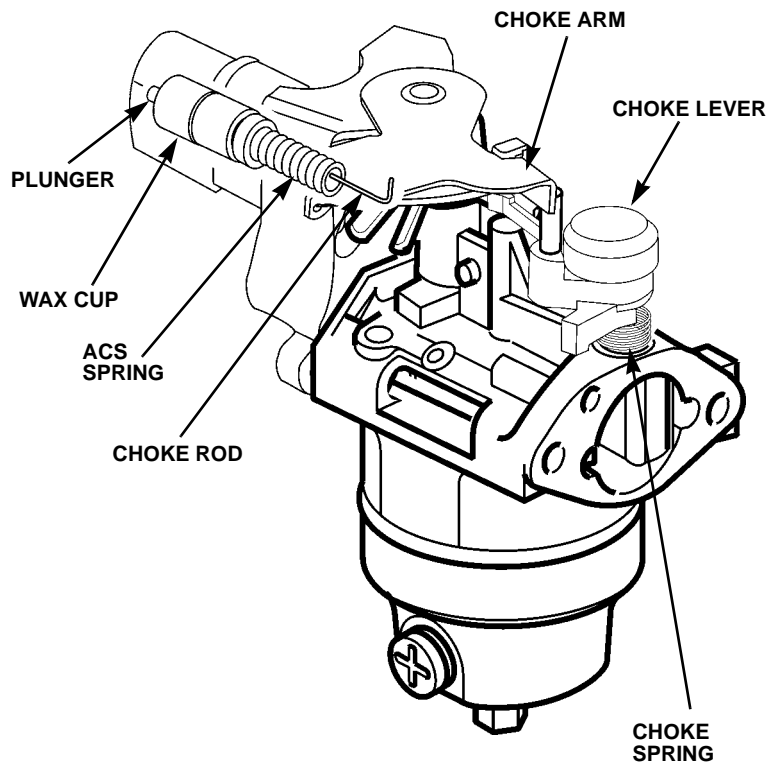



## OPERATION

---

### 2. ARCS (AUTO RETURN CHOKE SYSTEM)

Certain GCV160/190 engine types use Honda's Automatic Return Choke System or ARCS.

#### PRINCIPLE OF OPERATION

The operator closes the choke, and the system opens the choke using a small gear case (located in the choke base) filled with temperature sensitive grease.

The gear case senses the engine block temperature as well as the ambient air temperature. The grease gets thicker or thinner depending on the temperature. As the grease gets thicker (colder), the time the choke stays engaged is increased. As the grease gets thinner (hotter), the choke engagement time is reduced.

When you move the choke lever to the choke ON position, the lock return spring forces the choke lock to hold the choke lever in the choke ON position until the flywheel brake lever is engaged. The choke lever assembly moves the choke plate to engage the choke lever on the carburetor, closing the choke valve.

When the flywheel brake lever on the product is engaged, the choke rod pulls the choke lock to release the choke lever. As the choke lever opens, the choke lever on the carburetor is allowed to open by the force of the choke lever spring, and the choke valve slowly returns to the open position.

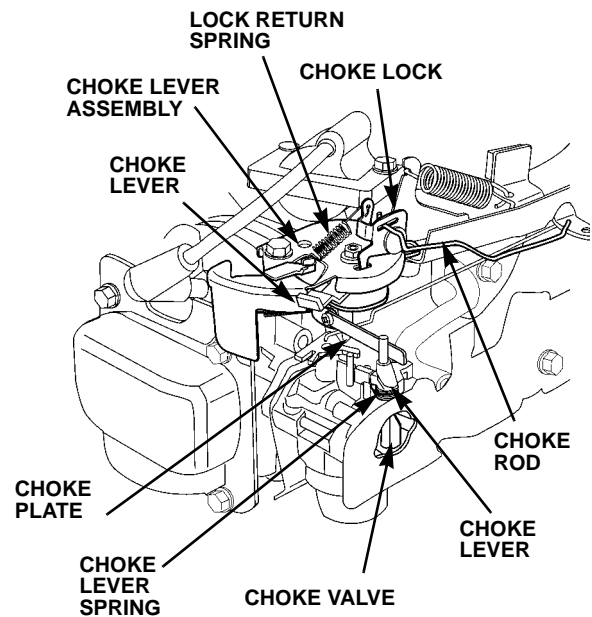

### 3. ROTO-STOP<sup>®</sup> MECHANISM

This system is designed to automatically stop the rotation of the lawn mower blades when the operator releases the blade control lever.

#### a. BLADE CONTROL LEVER PUSHED AGAINST HANDLEBAR

With the blade control lever against the handlebar, the ball plate rotates, forcing the three steel balls into the deeper part of the ramps allowing the brake plate to be pushed away from the driven disc by the ball plate spring. This releases the brake and allows the clutch spring to push on the driven disc, engaging the driven disc with the drive disc. The drive disc is keyed to the crankshaft and drive pulley. Power is transmitted to the blades for rotation.

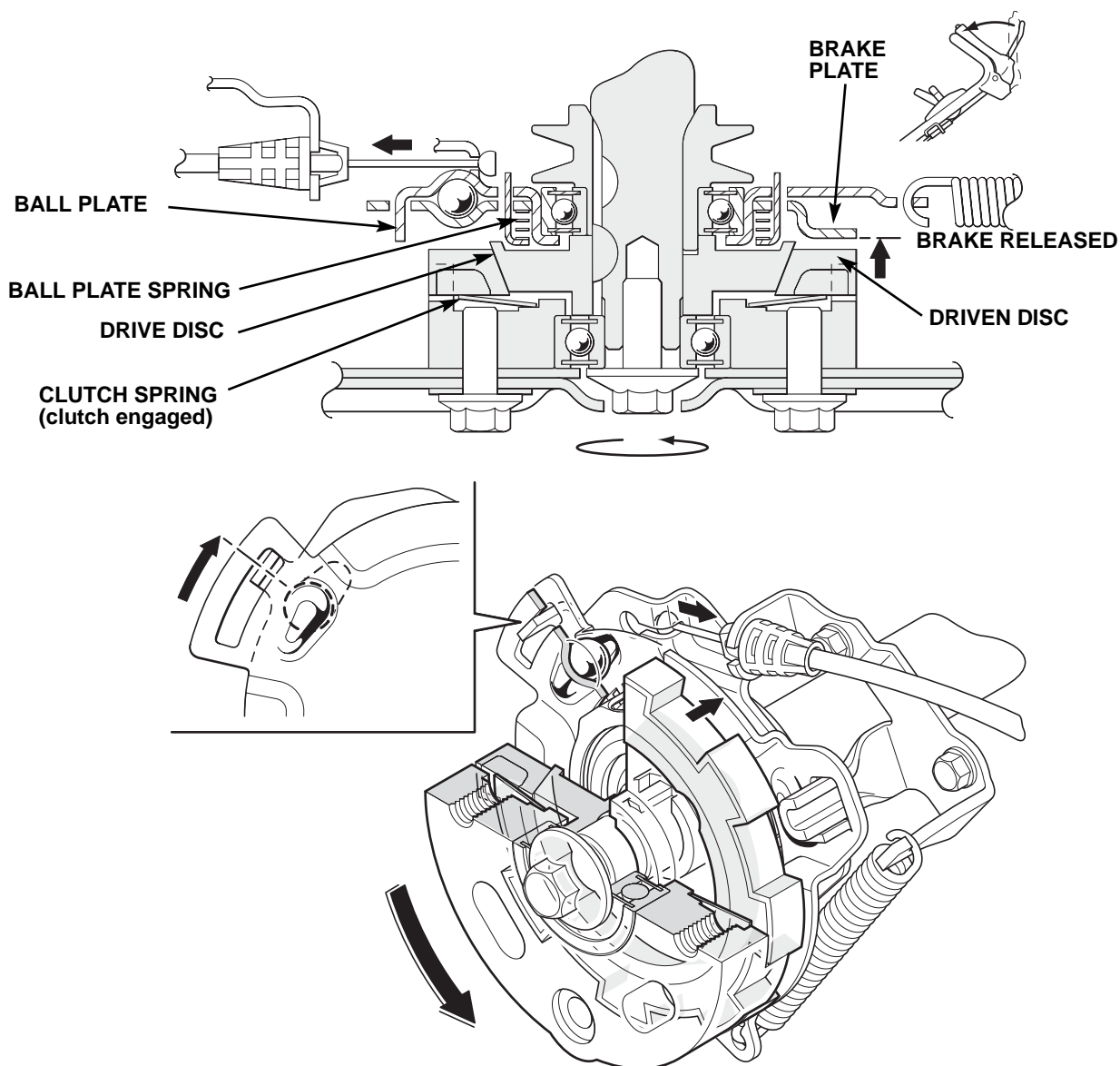

## OPERATION

### b. BLADE CONTROL LEVER RELEASED FROM HANDLEBAR

When the blade control lever is released from the handlebar, the blade control cable is released, allowing the ball plate to move down and apply the brake. The brake plate pushes down on the driven disc and compresses the clutch spring, causing the driven disc to be released from the drive disc. The application of the brake and disengagement of the clutch causes the driven disc, blade holder, and blades to quickly stop.

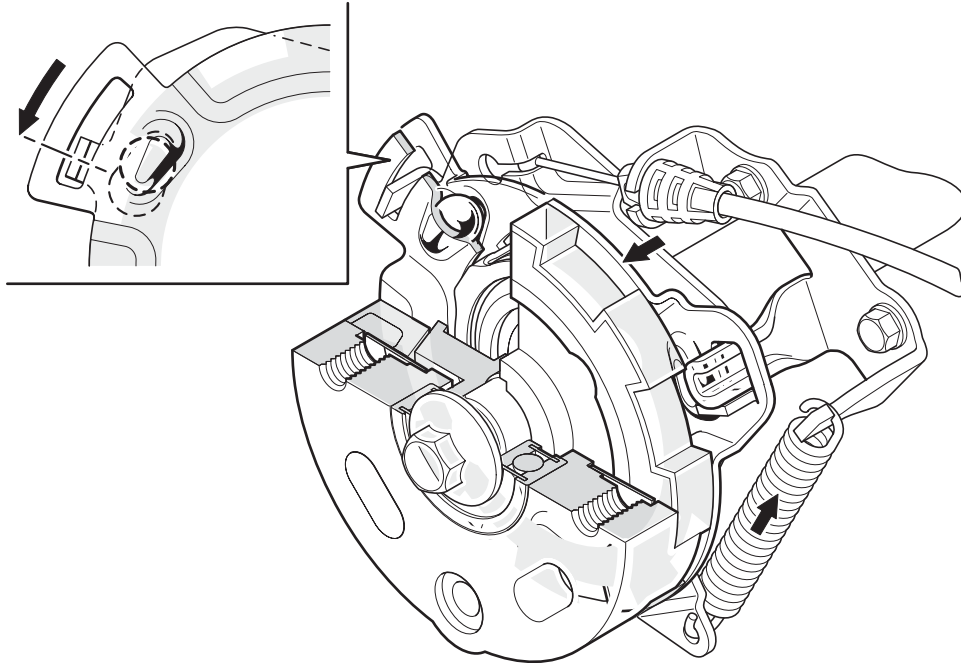
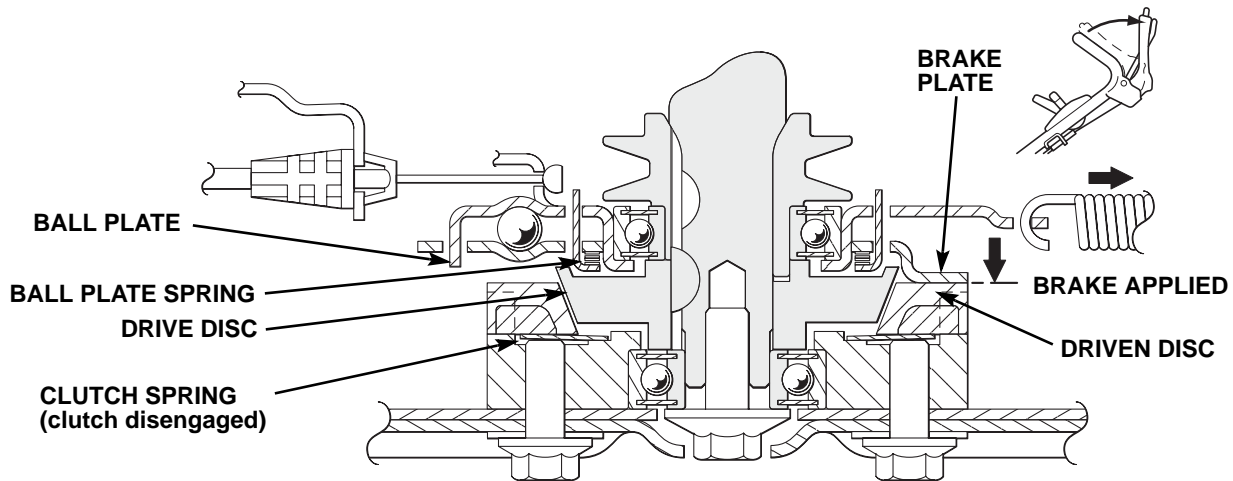

## 4. FUEL TANK CAP

### a. EVAPORATIVE EMISSION CONTROL SYSTEM

These engines have an EVAPORATIVE EMISSION CONTROL CANISTER built into the fuel tank cap to prevent the escape of gasoline vapors into the atmosphere. The cap also contains a ratchetting mechanism that will click when the cap is properly sealed and prevent the cap from being overtightened.

### b. PRINCIPLE

#### Charging

Gasoline vapor is produced in the fuel tank at high ambient temperatures. The gasoline in the vapor is absorbed and stored by the charcoal in the canister, which is built into the fuel tank cap.

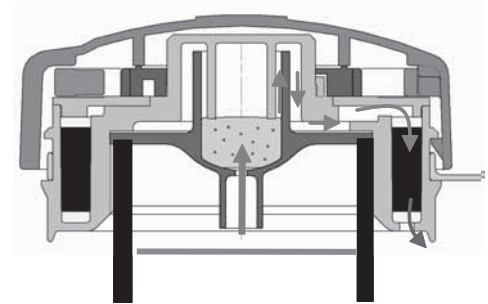

#### Purging

When the pressure in the fuel tank decreases because of low ambient temperature or consumption of gasoline, the air drawn through the canister absorbs the stored gasoline from the charcoal. This gasoline vapor returns to the fuel tank.

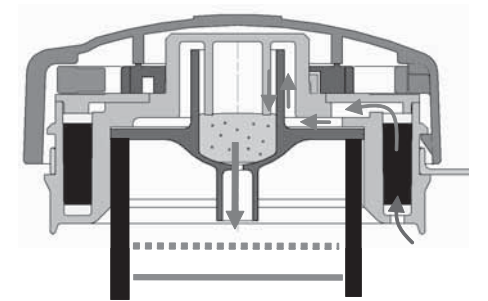

## OPERATION

### 5. AUTO THROTTLE®

#### Principle Of Operation

The system opens and closes the throttle using a diaphragm assembly that has a rod connected to the governor arm on one end and a vacuum hose connected to the insulator vacuum port on the other end. The diaphragm is pulled on by vacuum created in the intake manifold.

When the engine is started with no load, the throttle plate is slightly open and the vacuum is HIGH in the intake manifold. The high vacuum pulls on the diaphragm. The diaphragm rod is pulled in the direction shown and the governor arm is pulled to move the throttle arm to the idle position.

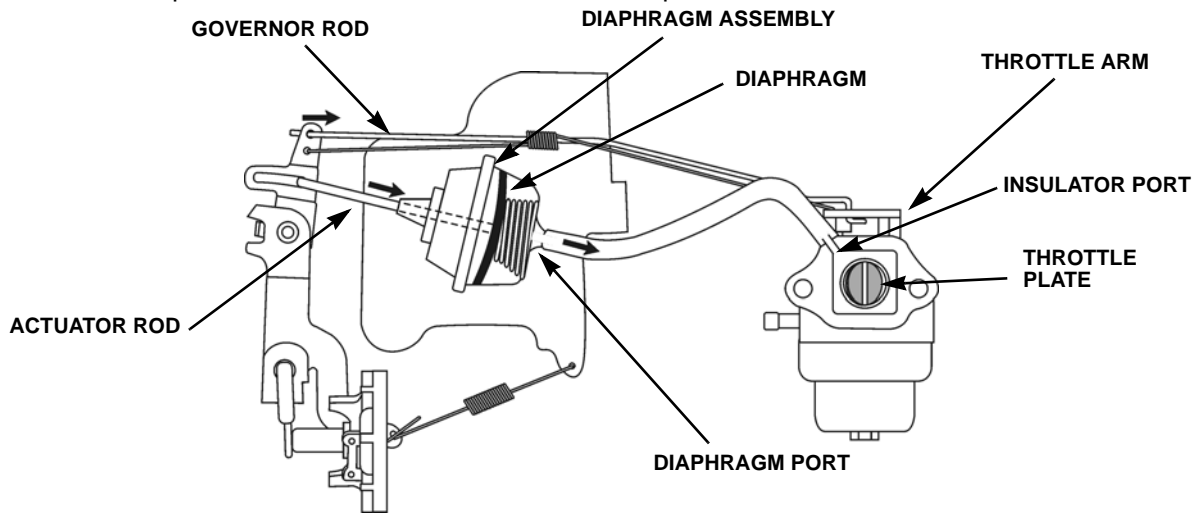

When a load is applied, the governor moves the throttle to the OPEN position. The vacuum in the intake manifold decreases, the spring behind the diaphragm assists in pushing the diaphragm to its neutral position, and the governor arm is released to operate normally.

